



Victoria Government Gazette

No. G 38 Thursday 19 September 2002

GENERAL

GENERAL AND PERIODICAL GAZETTE

Copy to: Gazette Officer
The Craftsman Press Pty. Ltd.
125 Highbury Road,
Burwood Vic 3125
Telephone: (03) 9926 1233
Facsimile: (03) 9926 1292
DX: 32510 Burwood
Email: gazette@craftpress.com.au

Advertising Rates and Payment

All prices include GST

Private Notices

Payment must be received in advance with advertisement details.

33 cents per word – Full page \$198.00.

Additional costs must be included in prepayment if a copy of the gazette is required. Copy Prices – Page
\$1.65 – Gazette \$3.52 – Certified copy of Gazette \$3.85
(all prices include postage). *Cheques should be made payable to The Craftsman Press Pty. Ltd.*

Government and Outer Budget Sector Agencies Notices

Not required to prepay.

Advertisements may be faxed or sent via email with a cover sheet, marked to the attention of the Gazette Officer. Floppy Disks (Mac & PC) can also be accepted.

Costs can be calculated on the following basis:

Per Line	Typeset
Single column	\$1.71
Double column	\$3.41
Full Page	\$71.28

The Craftsman Press is pleased to offer a series of discounts from the typesetting costs.

1. Copy supplied on disk.
2. Copy supplied via email.
3. Artwork for forms and other material which require exact reproduction.

1. Copy supplied on disk.

Where a disk is supplied and there is minimum alteration required, 30% off.

Where a disk is supplied requiring extraneous matter stripped out and styles applied, 20% off.

2. Copy supplied via email.

Where a notice is sent via email and there is minimum alteration required, 25% off.

Where email is supplied requiring extraneous matter stripped out and styles applied, 15% off.

3. Artwork for forms and other material which requires exact reproduction.

Scanning and sizing of artwork for forms, to be reproduced in page format, 35% off.

Copy Deadline for General Gazette

9.30 a.m. Monday – (Private Notices)

9.30 a.m. Tuesday – (Government and Outer Budget Sector Agencies Notices)

Advertisers should note:

- Late copy received at The Craftsman Press Pty. Ltd. after deadlines will be placed in the following issue of VGG, irrespective of any date/s mentioned in the copy (unless otherwise advised).
- Late withdrawal of advertisements (after client approval, before printing) will incur 50 per cent of the full advertising rate to cover typesetting, layout and proofreading costs.
- Proofs will be supplied only when requested or at the direction of the Gazette Officer.
- No additions or amendments to material for publications will be accepted by telephone.
- Orders in Council may be lodged prior to receiving assent with the Governor's or Clerk's signature. They will only be published once approved and signed.
- Accounts over 90 days will be issued with a letter of demand.
- Government and Outer Budget Sector Agencies please note: *See style requirements on back page.*

SPECIAL GAZETTES

Copy to: Gazette Officer
The Craftsman Press Pty. Ltd.
125 Highbury Road
Burwood Vic 3125
Telephone: (03) 9926 1233
Facsimile: (03) 9926 1292
Email: gazette@craftpress.com.au

Advertising Rates and Payment

Private Notices

Full Page \$396.00

Payment must be received in advance with notice details.

Government and Outer Budget Sector Agencies Notices

	Typeset
Full Page	\$96.25

Note:

The after hours number for Special Gazettes is:
Telephone: 0419 327 321

SUBSCRIPTIONS AND RETAIL SALES

Copies of the *Victoria Government Gazette* can be purchased from The Craftsman Press Pty. Ltd. by subscription.

The *Victoria Government Gazette*

General and Special – \$187.00 each year

General, Special and Periodical – \$249.70 each year

Periodical – \$124.30 each year

Subscriptions are payable in advance and accepted for a period of one year. All subscriptions are on a firm basis and refunds will not be given.

All payments should be made payable to The Craftsman Press Pty. Ltd.

Subscription enquiries:

The Craftsman Press Pty. Ltd.
125 Highbury Road, Burwood Vic 3125
Telephone: (03) 9926 1233

INDEX TO PRIVATE ADVERTISERS

A	<p>Mahons with Yuncken & Yuncken2474</p> <p>A.B. Natoli Pty.2472</p> <p>Mal. Ryan & Glen2475</p> <p>Andrew G. J. Rowan2472</p>
B	<p>Patricia M. Carroll2475</p> <p>Basile Pino & Co.2472</p> <p>Pietrzak Solicitors2475</p> <p>Bruce M. Cook & Associates2472</p>
C	<p>Stidston & Williams Weblaw2475</p> <p>Calleas Le Brun & Burke2472</p>
D	<p>Verna A. Cook2476</p> <p>Davine Fitzpatrick2472</p> <p>Dwyer Mahon & Robertson2473</p>
G	<p>Gill Kane & Brophy2473</p> <p>Gray Friend & Long2473</p>
H	<p>Harry M. Hearn2473</p>
J	<p>John Keating & Associates2473</p> <p>John Matthies & Co.2473</p> <p>John Stewart2474</p>
L	<p>Littleton Hackford2474</p>
M	<p>McKean & Park2474</p>

PRIVATE ADVERTISEMENTS

A Three-day course
Melbourne

Investigation Methods™

Are you an auditor, by-laws officer, compliance officer, council inspector, equal opportunity officer, workplace inspector, internal fraud investigator or a person employed in a similar or supervisory or supportive role?

Are you required to investigate incidents, alleged or suspected breaches of legislation, policies, codes or procedures?

Do you wish to acquire or hone your investigation skills at a reasonable cost and in accord with contemporary standards of best practice?

The *Investigation Methods Course* offered by Education Design Systems Pty Limited (EDS) will assist you in meeting those needs.

Now in its 14th year, this course has a national reputation as a highly relevant professional development program which generates significant returns on investment for participants and their organisations.

Dates: Wednesday 23 to Friday 25 October 2002 - 9.00am to 4.00pm

Venue: The Downtowner On Lygon Hotel, 66 Lygon Street, Carlton

Cost: \$1100 (includes GST, handbook, morning & afternoon refreshments & certificate of attendance)

For further information and registration contact: EDS Secretariat, Conference Co-ordinators on

Telephone: 02 6292 9000 - Facsimile: 02 6292 9002 - Email: confco@austarmetro.com.au

Website: www.eds.tc



Education Design Systems Pty Limited

ABN 65 008 665 432

A national training organisation incorporated in 1990 and endorsed in accord with International Standard AS/NZS ISO 9001:2000



Excellence In Professional Development

Co-operative Housing Societies Act 1958

EASTERN PENINSULA CO-OPERATIVE HOUSING SOCIETY LTD (IN LIQUIDATION)

Take notice that the affairs of the abovenamed Society are now fully wound up and that in pursuance of the Corporations Law and the **Co-operative Housing Societies Act 1958**, a general Meeting of the Society will be held at Suite 1, 614 Hawthorn Road, East Brighton, Victoria on 6 November 2002 at 5.00 p.m. for the purposes of:

- (i) laying before it an account showing how the winding up has been conducted and the property of the society disposed of and giving an explanation thereof, and
- (ii) passing a resolution that the books and papers of the Society and of the Liquidator relevant to the affairs of the Society be destroyed after a period of twelve months from the date of the meeting.

Dated 9 September 2002

BRIAN ROYER SOWARD COMFORT,
Liquidator.

DISSOLUTION OF PARTNERSHIP

Pursuant to section 36(c) of the **Partnership Act 1958** (Vic.), notice is hereby served of the intention of 234 Flinders Lane Pty Ltd to dissolve the partnership between 234 Flinders Lane Pty Ltd and Manchester House Pty Ltd ("the partnership") as of 1 October 2002.

DISSOLUTION OF PARTNERSHIP

Notice is hereby given that the partnership previously subsisting between Barry Edward Eeles of 23 Popes Road, Junortoun 3551 and Graham Ernest Eeles of 20 O'Neill Street, Bendigo, carrying on business as sulky sales and repairs at Lot 8 Popes Road, Junortoun 3551, under the style or firm of Sulky Shop Australia, has been dissolved as from 11 September 2002. All debts due to and owing by the said firm will be received and paid respectively by the said Barry Edward Eeles.

Dated 11 September 2002

BARRY EDWARD EELES
23 Popes Road, Junortoun 3551.

2472 G 38 19 September 2002

Victoria Government Gazette

DULCIE MAY SHORT, late of Clarence Parkside Court, 18 Clarence Street, Elsternwick, Victoria, widow, deceased. Creditors, next-of-kin and others having claims in respect of the estate of the abovenamed deceased, who died on 7 May 2002, are required by Gwenda Florence Latham, the executor of the deceased's will, to send particulars of their claim to the said executor care of the undermentioned solicitors by a date not later than two months from the date of publication hereof, after which date she will convey or distribute the assets having regard only to the claims of which she then has notice.

A. B. NATOLI PTY., solicitors,
24 Cotham Road, Kew 3101.

IRENE REBECCA LOUISA CLIFFE, late of "Rosewood Downs", 24 Railway Parade, Dandenong, Victoria, widow, deceased. Creditors, next-of-kin and others having claims in respect of the estate of the deceased, who died on 3 July 2002, are required by Equity Trustees Limited, ACN 004 031 298, the proving executor of the will of the deceased, to send particulars of their claims to the executor in the care of the undermentioned solicitor by 22 November 2002 after which date the executor may convey or distribute the assets having regard only to the claims of which it then has notice.

ANDREW G. J. ROWAN, solicitor,
Level 4, 472 Bourke Street, Melbourne 3000.

In the estate of COLIN WILLIAM ROBINSON, deceased of 53 Station Street, Lake Boga, in the State of Victoria, cartage contractor. Creditors, next-of-kin and all other persons having claims against the estate of the said deceased, who died on 5 July 2001, are required by Margaret Rose Robinson, home duties of Kerang Street, Lake Boga, in the State of Victoria, the sole beneficiary under the will of the estate of the said deceased, to send particulars of such claims to her care of the undermentioned solicitors on or before 29 November 2002 after which date she will distribute the assets having regard only to the claims of which she then has notice.

BASILE PINO & CO, barristers & solicitors,
213 Campbell Street, Swan Hill, Victoria 3585.
Telephone: (03) 5032 4809.

Re: Estate of ELLEN TUIM, deceased. Creditors, next-of-kin or others having claims in respect of the estate of ELLEN TUIM, of 2 Montpellier Road, Burwood, in the State of Victoria, home duties, who died on 21 July 2002, are to send particulars of their claims to the personal representative/s care of the undermentioned solicitors by 20 November 2002 after which date the personal representative/s will distribute the assets having regard only to the claims of which they then had notice.

BRUCE M. COOK & ASSOCIATES,
barristers & solicitors,
Level 19, AMP Tower,
535 Bourke Street, Melbourne, Vic. 3000.

SUZA BRNA (also known as Zuzana Brna), late of 9 Gundaroo Square, Werribee, in the State of Victoria, widow, deceased. Creditors, next-of-kin and other persons having claims against the estate of the said deceased, who died on 20 January 2002, are required to send particulars of same to the executor, John Brna, in the care of the undersigned on or before 19 November 2002 after which date he will distribute the assets having regard only to the claims of which he then has notice.

CALLEAS LE BRUN & BURKE, solicitors,
1/44 Watton Street, Werribee.

Re: CAROLINE MARGARET BYRNES, late of Hazelwood House, 5 Philip Parade, Churchill, Victoria, but formerly of 41 Elgin Street, Morwell and 512 Racecourse Road, Flemington, gentlewoman, deceased. Creditors, next-of-kin and others having claims in respect of the estate of the deceased, who died on 21 June 2002, are required by the trustees, Patrick James Gleeson of 10 Desmond Street, Heighton, Victoria, retired, the nephew and Michael Francis Gleeson of 2610 Monash Way, Boolarra, Victoria, primary producer, the nephew, to send particulars to the below mentioned solicitors by 18 November 2002 after which date the trustees may convey or distribute the assets, having regard only to the claims of which the trustees have notice.

DAVINE FITZPATRICK, solicitors,
52 Albert Street, Moe 3825.

Re: Estate of ARTHUR JAMES DURAND, deceased. Creditors, next-of-kin or others having claims in respect of the estate of ARTHUR JAMES DURAND, late of 10 Bonview Road, North Balwyn, in the State of Victoria, sales manager, deceased, who died on 20 October 2000, are to send particulars of their claim to the administrator care of the undermentioned legal practitioners by 20 December 2002 after which the administrator will distribute the assets having regard only to the claims of which he then has notice.

DWYER MAHON & ROBERTSON,
legal practitioners,
Beveridge Dome,
194–208 Beveridge Street, Swan Hill.

Re: MARGUERITE LESLEY de JARLAIS, late of McKinnon Nursing Home, 97 Wheatley Road, McKinnon, Victoria, widow, deceased. Creditors, next-of-kin and others having claims in respect of the estate of the deceased, who died on 30 March 2002, are required by the trustee, William Charles Peter Styles of 11 Edith Court, Doncaster, Victoria, investor, the nephew, to send particulars to the trustee by 22 November 2002 after which date the trustee may convey or distribute the assets, having regard only to the claims of which the trustee has notice.

GILL KANE & BROPHY, solicitors,
1/520 Bourke Street, Melbourne 3000.

REGINALD JOHN SMITH, late of 5 Moroka Drive, Warragul, retired, deceased. Creditors, next-of-kin and others having claims in respect of the estate of the deceased, who died on 10 July 2002, are required by the trustees, Daryl John Smith and Alan Wayne Smith, to send particulars of their claims to them care of the undersigned solicitors by 19 November 2002 after which date the trustees may convey or distribute the assets having regard only to the claims of which they then have notice.

GRAY FRIEND & LONG, solicitors,
70 Queen Street, Warragul 3820.

BEATRICE JOYCE LLOYD, (also known as Joyce Lloyd) late of 20 Nairn Avenue, Ascot Vale in Victoria, retired CSIRO officer, deceased. Creditors, next-of-kin and others having claims in respect of the estate of the

deceased, who died on 18 July 2002, are required by the executor, Trust Company of Australia Limited of 151 Rathdowne Street, Carlton South, Victoria, to send particulars to them care of the undermentioned solicitors by 21 November 2002 after which date the executor may convey or distribute the assets having regard only to the claims of which it then has notice.

HARRY M. HEARN, solicitor,
443 Little Collins Street, Melbourne.

Creditors, next-of-kin or others having claims in respect of the estate of DANIEL FRANCIS MURPHY, late of Unit 2/24, Hatfield Street, North Balwyn, Victoria, wine merchant, deceased, who died on 26 December 2001, are to send particulars of their claims to the executrix, care of the undermentioned solicitors by 20 November 2002 after which date the executrix will distribute the assets having regard only to the claims of which the executrix then has notice.

JOHN KEATING & ASSOCIATES, solicitors,
191 Greville Street, Prahran 3181.

Creditors, next-of-kin or others having claims in respect of the estate of KEITH LESLIE WEATHERLY, late of 10 Evelina Road, Toorak, Victoria, gentleman, deceased, who died on 2 July 2002, are to send particulars of their claims to the executor care of the undermentioned solicitors by 20 November 2002 after which date the executor will distribute the assets having regard only to the claims of which the executor then has notice.

JOHN KEATING & ASSOCIATES, solicitors,
191 Greville Street, Prahran 3181.

Re: DOROTHY JOAN McPHEE. Creditors, next-of-kin and others having claims in respect of the estate of DOROTHY JOAN McPHEE, late of 32 Gordon Street, Hampton, Victoria, spinster, deceased, who died on 22 April 2002, are required by the executor of the estate, Trust Company of Australia Limited, A.C.N. 004 027 479 of 151 Rathdowne Street, Carlton South, Victoria 3053, to send particulars of their claims to the executor at its address of 151 Rathdowne Street, Carlton South, Victoria 3053 by 30 November 2002 after which date the

2474 G 38 19 September 2002

Victoria Government Gazette

executor may convey or distribute the assets having regard only to the claims of which it then has notice.

JOHN MATTHIES & CO.,
legal practitioners for the applicant,
6th Floor, 416 Collins Street, Melbourne 3000.

Re: VERA MAY HYLAND. Creditors, next-of-kin and others having claims in respect of the estate of VERA MAY HYLAND, late of 12 Hodder Street, East Brighton, Victoria, widow, deceased, who died on 7 June 2002, are required by the executor of the estate, Trust Company of Australia Limited, A.C.N. 004 027 479 of 151 Rathdowne Street, Carlton South, Victoria 3053, to send particulars of their claims to the executor at its address of 151 Rathdowne Street, Carlton South, Victoria 3053 by 30 November 2002 after which date the executor may convey or distribute the assets having regard only to the claims of which it then has notice.

JOHN MATTHIES & CO.,
legal practitioners for the applicant,
6th Floor, 416 Collins Street, Melbourne 3000.

Creditors, next-of-kin and others having claims in respect of the will of MARIA VISALLI, late of 40 Epsom Road, Kensington, Victoria, home duties, deceased, who died on 24 July 2002, are requested to send particulars of their claims to the executor, Giuseppe Visalli, care of the undermentioned legal practitioner by 20 November 2002 after which date he will distribute the assets having regard only as to the claims of which he then has notice.

JOHN STEWART, legal practitioner,
290 Racecourse Road, Newmarket.

JUNE ANNIE HELEN CAMPBELL, late of 3 Josephine Street, Oak Park, Victoria. Creditors, next-of-kin and others having claims in respect of the estate of the deceased, who died on 18 May 2002, are required by Perpetual Trustees Victoria Limited, ACN 004 027 258 of 360 Collins Street, Melbourne, Victoria and Judith Ann Watson of 3 Rosella Court, West Meadows, Victoria, to send particulars of their claims to the said company by 20 November 2002 after which date it will convey or distribute the assets having regard only to the claims of which the company then has notice.

Creditors, next-of-kin and others having claims in respect of the estate of ANNE ISOBEL WALKLEY, late of Stretton Park, Maffra, Victoria, retired school teacher, deceased, who died on 27 June 2002, are to send their claims to the trustees, Peter James Walkley of 4 Railway Parade, Glengarry, Victoria and Maryanne Walkley of 30 Gibdon Street, Burnley, Victoria, care of the below mentioned solicitors by 18 November 2002 after which date they will distribute the assets of the deceased having regard only to the claims of which they then have notice.

LITTLETON HACKFORD, solicitors,
Law Chambers,
115 Hotham Street, Traralgon, Vic. 3844.

Creditors, next-of-kin and others having claims in respect of the estate of JOHN LENNOX DYER, late of Brookfield Park Nursing Home, 69 Liddiard Road, Traralgon, Victoria, retired sawmiller, deceased, who died on 20 August 2002, are to send their claims to the trustees, Peter John Christian Dyer of 4 Wallace Court, Traralgon, Victoria and Anthony Lennox Dyer of 100 Springhall Parade, Pascoe Vale South, Victoria, care of the below mentioned solicitors by 20 November 2002 after which date they will distribute the assets of the deceased having regard only to the claims of which they then have notice.

LITTLETON HACKFORD, solicitors,
Law Chambers,
115 Hotham Street, Traralgon, Vic. 3844.

Re: JOHANNIS NICOLAAS HUYSMANS, late of 1 Elka Road, Springvale, Victoria, retired, deceased. Creditors, next-of-kin and others having claims in respect of the estate of the deceased, who died on 4 March 2002, are required by the trustee, Equity Trustees Limited, to send particulars to the trustee care of the undermentioned solicitors by 29 November 2002 after which date the trustee may convey or distribute the assets, having regard only to the claims of which it then has notice.

McKEAN & PARK, lawyers & consultants,
405 Little Bourke Street, Melbourne 3000.

Re: ALMA ROSE GEAL, late of
124 Blackburn Road, Blackburn, Victoria,

widow, deceased. Creditors, next-of-kin and others having claims in respect of the estate of the deceased, who died on 11 February 2002, are required by the trustees, Alan Neil Cross and Thomas Murray Clapperton, to send particulars to the trustees to Mahons with Yuncken & Yuncken, PO Box 584, Blackburn 3130 by 20 November 2002 after which date the trustees may convey or distribute the assets, having regard only to the claims of which the trustees have notice.

MAHONS with YUNCKEN & YUNCKEN,
solicitors,
178 Whitehorse Road, Blackburn 3130.

Re: MARIAN ANDERSON, late of 59 Gardenia Street, Blackburn, Victoria, but formerly of 9 Banksia Street, Warragul, home duties, deceased. Creditors, next-of-kin and others having claims in respect of the estate of the deceased, who died on 5 May 2002, are required by the trustees, Bruce Frederick Anderson and Peter Thomas Shaw, to send particulars to the trustees by 20 November 2002 to Mahons with Yuncken & Yuncken, PO Box 584, Blackburn 3130, after which date the trustees may convey or distribute the assets, having regard only to the claims of which the trustees have notice.

MAHONS with YUNCKEN & YUNCKEN,
solicitors,
178 Whitehorse Road, Blackburn 3130.

MAXWELL JOHN BLAKENEY, late of "Claremont", Yarck, Victoria, retired grazier. Creditors, next-of-kin and others having claims in respect of the estate of the deceased, who died on 23 June 2002, are required by the applicants for grant of representation in the estate, Hayley Joy Blakeney and Jock David Blakeney, to send particulars to them at the office of the undermentioned firm of solicitors by 3 December 2002 after which date the applicants for grant of representation may convey or distribute the assets having regard only to the claims of which they then have notice.

MAL. RYAN & GLEN,
solicitors for the applicants,
9 High Street, Mansfield 3722.

Creditors, next-of-kin and other persons having claims against the estate of PEGGY PATRICIA CLARK, late of Carnsworth Nursing Home, 10 A'Beckett Street, Kew, Victoria, widow, are required by the executors, Catherine Mary Pearce of 5 Coppin Grove, Hawthorn, Victoria, medical practitioner and John Benedict Clark of 12 Stephen Street, Newtown, Victoria, medical practitioner, to send detailed particulars of their claim to the said executors care of the undermentioned solicitor by 30 November 2002 after which date the executors will proceed to distribute the estate having regard only to the claims of which they have notice.

PATRICIA M. CARROLL, solicitor,
Level 8, 150 Queen Street, Melbourne.

Creditors, next-of-kin and others having claims in respect of the estate of JAN CABENKO, late of 19 Mahoneys Road, Reservoir, in the State of Victoria, pensioner, deceased, who died on 9 September 2002, are required to send particulars of such claims to the executor care of the undermentioned solicitors by 18 November 2002 after which date the executor will convey or distribute the assets having regard only to the claims of which the executor then has notice.

PIETRZAK SOLICITORS,
222 Latrobe Street, Melbourne.

GRAHAM RONALD CAVILL, late of 16 Hakea Drive, Mount Martha, Victoria, deceased. Creditors, next-of-kin and others having claims in respect of the estate of the deceased, who died on 2 June 2002, are required by the trustee, Linda Clarice Caville of 16 Hakea Drive, Mount Martha, Victoria, to send particulars to her by 18 November 2002 after which date the trustee may convey or distribute the assets, having regard only to the claims of which she then has notice.

STIDSTON & WILLIAMS WEBLAW,
solicitors,
313 Main Street, Mornington.

MARGUERITE HIGGINS, late of Corowa Court, 752 The Esplanade, Mornington, Victoria, deceased. Creditors, next-of-kin and others having claims in respect of the estate of

2476 G 38 19 September 2002

Victoria Government Gazette

the deceased, who died on 12 June 2002, are required by the trustee, Trevor Bruce Crowle of 16 Bradford Road, Mount Martha, Victoria, to send particulars to him by 23 November 2002 after which date the trustee may convey or distribute the assets, having regard only to the claims of which he then has notice.

STIDSTON & WILLIAMS WEBLAW,
solicitors,
313 Main Street, Mornington.

NOREEN BROWNE, deceased. Creditors, next-of-kin and others having claims in respect of the estate of NOREEN BROWNE, late of Ashleigh Lodge, 58 Cochrane Street, Brighton, Victoria, retired, deceased, who died on 16 July 2002, are required to send particulars of their claims to the executor care of the undermentioned solicitor by 18 November 2002 after which date the executor will proceed to distribute the assets having regard only to the claims of which she shall then have notice.

VERNA A. COOK, solicitor,
5/8 St. Andrews Street, Brighton 3186.

In the Supreme Court of the State of Victoria
SALE BY THE SHERIFF

On 23 October 2002 at 2.30 p.m. at the Sheriff's Office, 8-20 King Street, Oakleigh, (unless process be stayed or satisfied).

All the estate and interest (if any) of Paul Deller of 2 Dalmatia Court, Rowville, as shown on Certificate of Title as Paul Leslie Deller, joint proprietor with Myra Lorino Deller of an estate in fee simple in the land described on Certificate of Title Volume 10359, Folio 350 upon which is erected a home known as 2 Dalmatia Court, Rowville.

Registered Mortgage No. W801596M and Covenant No. V254262J affect the said estate and interest.

Terms – Cash/Eftpos
(Debit Cards only. No Credit Cards).

SW-02-005588-4

Dated 19 September 2002

V. PARKIN
Sheriff's Office

In the Supreme Court of the State of Victoria
SALE BY THE SHERIFF

On 23 October 2002 at 2.30 p.m. at the Sheriff's Office, 8-20 King Street, Oakleigh, (unless process be stayed or satisfied).

All the estate and interest (if any) of Arthur Evriniadis also known as Athansios Evriniadis of 26 Mahoney Street, Templestowe, as shown on Certificate of Title as Athanasios Evriniadis, proprietor of an estate in fee simple in two of a total of four equal undivided shares registered as Tenants in Common with Hristos Evriniadis as to one of a total of four equal undivided shares, Ermioni Evriniadis as to one of a total of four equal undivided shares and being the land described on Certificate of Title Volume 8244, Folio 009 upon which is erected a house known as 5 Lankester Street, Templestowe.

Registered Mortgage No. W728388T affects the said estate and interest.

Terms – Cash/Eftpos
(Debit Cards only. No Credit Cards).

SW-02-003533-6

Dated 19 September 2002

V. PARKIN
Sheriff's Office

In the Supreme Court of the State of Victoria
SALE BY THE SHERIFF

On 23 October 2002 at 2.30 p.m. at the Sheriff's Office, 8-20 King Street, Oakleigh, (unless process be stayed or satisfied).

All the estate and interest (if any) of Irini Dictos Nicolades of 13 Karwitha Street, Vermont, proprietor of an estate in fee simple in the land described on Certificate of Title Volume 6024, Folio 718 upon which is erected a dwelling known as 288 Malvern Road, Prahran.

Registered Mortgage No. T930124A and Caveat No. X774356R affect the said estate and interest.

Terms – Cash/Eftpos
(Debit Cards only. No Credit Cards).

SW-02-003321-3

Dated 19 September 2002

V. PARKIN
Sheriff's Office

Victoria Government Gazette

G 38 19 September 2002 2477

In the Supreme Court of the State of Victoria

SALE BY THE SHERIFF

On Wednesday 23 October 2002 at 2.30 p.m. at the Sheriff's Office, 8-20 King Street, Oakleigh, (unless process be stayed or satisfied).

All the estate and interest (if any) of Mark Linden O'Meara of 55 Cottrell Street, Werribee, proprietor of an estate in fee simple in the land described on Certificate of Title Volume 8152, Folio 192 upon which is erected a house known as 55 Cottrell Street, Werribee.

Registered Mortgage No. W120070U and Caveat No. X219360N affect the said estate and interest.

Terms – Cash/Eftpos
(Debit Cards only. No Credit Cards).

SW-01-011822-7

Dated 19 September 2002

V. PARKIN
Sheriff's Office

In the Supreme Court of the State of Victoria

SALE BY THE SHERIFF

On Friday 25 October 2002 at 11.00 a.m. at the Sheriff's Office, 107 Baxter Street, Bendigo, (unless process be stayed or satisfied).

All the estate and interest (if any) of Danuta Elizabeth Welsh of 28 Simpson Street, Sunshine North, proprietor of an estate in fee simple in Crown Allotment 27, Section K, in the Parish of Neilborough consisting of 8.093 hectares or thereabouts and being the land more particularly described on Certificate of Title Volume 3813, Folio 584 upon which is erected a dwelling.

The property can be located by travelling from Bendigo in a northerly direction along the Loddon Valley Highway to Eaglehawk–Neilborough Road. Turn into Eaglehawk–Neilborough Road and travel to Blandfords Road, turn east, travel for approximately 700 metres along Blandfords Road to Welsh's Road. Turn south, travel for approximately 500 metres. The property is on the western side of the road and is known as Crown Allotment 27, Section K, Welsh's Road, Neilborough.

Terms – Cash only

SW-02-003187-1

Dated 19 September 2002

V. PARKIN
Sheriff's Office

2478 G 38 19 September 2002

Victoria Government Gazette

Unclaimed Moneys Act 1962

Register of Unclaimed Moneys held by the —

<i>Name of Owner on Books and Last Known Address</i>	<i>Total Amount Due to Owner</i>	<i>Description Of Unclaimed Money</i>	<i>Date when Amount first became Payable</i>
GPZ LEGAL PTY (FORMERLY GIASOUMI PAPASAVAS ZERVOS PTY)			
	\$		
Darren Webster	181.60	Cheque	30/03/00
02021 CONTACT: FIONA PHILLIPS, PHONE: (03) 9827 4291.			

Unclaimed Moneys Act 1962

Register of Unclaimed Moneys held by the —

<i>Name of Owner on Books and Last Known Address</i>	<i>Total Amount Due to Owner</i>	<i>Description Of Unclaimed Money</i>	<i>Date when Amount first became Payable</i>
BHP BILLITON LIMITED			
	Au. \$		
A. & E. C. Investments Pty Ltd, 82 Edgecliff Esplanade, Seaforth, NSW	717.75	Cheque	06/12/00
Mr Sergio Diyodi Abe, O1 Bp 6944 Abidjan, Cote D'Ivoire, Africa	275.00	"	"
Mrs Jeanne Roslyn J. Abelson, 3 Wolger Rd, Mosman, NSW	137.50	"	"
ACN 068907497 Pty Ltd, "DPA Super Fund A/c", Level 10/123 Lonsdale Street, Melbourne	175.00	"	"
ACN 068907497 Pty Ltd, "DPA Super Fund A/c", Level 10/123 Lonsdale Street, Melbourne	182.00	"	03/07/00
Action Refrigeration Aust Pty Ltd, "A/c Superannuation Fund", C/o John J. Doyle, 774 High Street, Thornbury	114.40	"	"
Mr Reece Henry Adnams & Mrs Kristy-Anne Adnams, 102/502 Little Collins Street, Melbourne	110.00	"	06/12/00
Mr Reece Henry Adnams & Mrs Kristy-Anne Adnams, 102/502 Little Collins Street, Melbourne	190.32	"	03/07/00
Mr Reece Henry Adnams & Mrs Kristy-Anne Adnams, 102/502 Little Collins Street, Melbourne	183.00	"	06/12/00
Miss Bronwyn Michelle Adshead, 2/54 Canning Highway, Victoria Park, WA	278.25	"	"
A.H.G. Clarke Nominees Pty Ltd, C/o 460 Bourke Street, Melbourne	231.53	"	03/07/00
A.H.G. Clarke Nominees Pty Ltd, C/o 460 Bourke Street, Melbourne	223.00	"	06/12/00
Mrs Helen Cecily Alcock, C/o Grosvenor Pirie Management Limited, GPO Box 263, Sydney, NSW	599.25	"	"

Victoria Government Gazette

G 38 19 September 2002 2479

Mrs Andrea Austin Alexander, 33 Belmore Road, North Balwyn	425.97	”	03/07/00
Mrs Andrea Austin Alexander, 33 Belmore Road, North Balwyn	400.25	”	06/12/00
Miss Karen M. Alexander, C/o Mrs Karen Witty 85 Jubilee Road, Wellington, NZ	101.00	”	”
Mrs Jocelyn Alford & Mr Jack Beresford Shannon, 144A Ocean Beach Road, Mount Maunganui, NZ	271.75	”	”
Mr Reece Kelvin Alldritt, 289 Eastern Valley Highway, Middle Cove, NSW	261.54	”	03/07/00
Mr Reece Kelvin Alldritt, 289 Eastern Valley Highway, Middle Cove, NSW	245.00	”	06/12/00
Est Late Louis Sydney Allen, C/o P. M. Palmer, 11 Valley Road, Lindfield, NSW	438.82	”	03/07/00
Est Late Louis Sydney Allen, C/o P. M. Palmer, 11 Valley Road, Lindfield, NSW	422.25	”	06/12/00
Mrs Rosemary A. Allsop, 30 Huntleys Point Road, Huntleys Point, NSW	129.25	”	”
Altania Pty Limited, C/o Barry Mendel Frank & Co Services Pty Ltd, Level 53, MLC Centre, Martin Place, Sydney, NSW	2,839.46	”	03/07/00
Altania Pty Limited, C/o Barry Mendel Frank & Co Services Pty Ltd, Level 53, MLC Centre, Martin Place, Sydney, NSW	2,730.25	”	06/12/00
Mr David Ian Ambrose & Mrs Patricia Mary Ambrose, 113 Buena Vista Avenue, Coorparoo, Qld	163.50	”	”
Mr David Ian Ambrose & Mrs Patricia Mary Ambrose, 113 Buena Vista Avenue, Coorparoo, Qld	179.08	”	03/07/00
Anatolia Investments Pty Ltd, 26 Elizabeth Street, Paddington, NSW	10,169.75	”	06/12/00
Anatolia Investments Pty Ltd, 26 Elizabeth Street, Paddington, NSW	10,576.54	”	03/07/00
Miss Janet Mary Anderson, 5/179 High Street, North Sydney, NSW	619.00	”	06/12/00
Mr Robert Murray Anderson, 5/57 New Beach Road, Darling Point, NSW	1,181.13	”	03/07/00
Mr Robert Murray Anderson, 5/57 New Beach Road, Darling Point, NSW	1,121.75	”	06/12/00
Mr Kevin Ralph Andress, PO Box 118, Jesmond, NSW	166.40	”	03/07/00
Mr Kevin Ralph Andress, PO Box 118, Jesmond, NSW	160.00	”	06/12/00
Mrs Theda Isabel Annells, 4 Patterson Street, Middle Park	554.58	”	03/07/00
Mrs Theda Isabel Annells, 4 Patterson Street, Middle Park	533.25	”	06/12/00
Dr Francis L. Archer, 301 Lennox Street, Richmond	290.37	”	03/07/00
Dr Francis L. Archer, 301 Lennox Street, Richmond	279.75	”	06/12/00
Dr Anthony Arden & Dr Felix Wilfrid Arden, “Anthony Arden Superfund A/c”, Alexandra, 201 Wickham Terrace, Brisbane, Qld	183.50	”	”
Armstrong Jones Life Assurance Ltd, PO Box H85, Australia Square, Sydney, NSW	759.25	”	”
Armstrong Jones Life Assurance Ltd, PO Box H85, Australia Square, Sydney, NSW	800.67	”	03/07/00
Ms Moyia Armstrong, 2/21 George Street, Barwon Heads	130.00	”	”

2480 G 38 19 September 2002

Victoria Government Gazette

Ms Moyia Armstrong, 2/21 George Street, Barwon Heads	125.00	''	06/12/00
Mr Noel Leslie John Armstrong, C/- B. Mitchell, Dixon Road Rd 2, Hamilton, NZ	147.13	''	03/07/00
Mrs Wendy Margaret Armstrong , "A/c ATF Hamilton P. Armstrong", Peregrin, Eglinton, NSW	135.50	''	06/12/00
Mr John Michael Arney, 19 Meadowland Rd, Peakhurst, NSW	195.14	''	03/07/00
Mr James Justin Arthur, Hawthorn Road, The Mullion Via Yass, NSW	115.25	''	06/12/00
Mr Gottlieb Artwoeger & Mrs Adelinde Artwoeger, 7 Market Street, Bankstown, NSW	105.50	''	''
Mr Cunningham Atchison, 6 Alexander Street, Howick, Auckland, New Zealand	137.50	''	06/12/00
Mr Cunningham Atchison, 6 Alexander Street, Howick, Auckland, New Zealand	143.00	''	03/07/00
Mr Robert David Atkinson, GPO Box 11011, Hobart, Tas.	247.70	''	''
Mr Robert David Atkinson, GPO Box 11011, Hobart, Tas.	238.50	''	06/12/00
Aurora Management Pty Ltd, "Ehmcke Family S/F A/c", 145 Victoria Road, Bellevue Hill, NSW	129.00	''	''
Miss Sandra June Auty, Main Street, Mount Molloy, Qld	219.27	''	03/07/00
Miss Sandra June Auty, Main Street, Mount Molloy, Qld	206.50	''	06/12/00
Miss Genevieve Jean Ayre, 46 Birdwood Street, Parkdale	143.50	''	''
Mr Geoffrey Paul Bachmann, Lot 8, Galea Court, Habana, Qld	275.00	''	''
Mr Murray Charles Bailes, 56 Fairlight St, Fairlight, NSW	250.00	''	''
Mr Brian John Bailey, 10 Guilden Green, Guilden Sutton, Chester, CH3 7SP United Kingdom	611.00	''	''
Miss Barbara R. Baird, 6E Point Piper House, 4 Buckhurst Avenue, Point Piper, NSW	290.00	''	''
Mr Christopher Charles Baker, 31 Jellicoe Road, Murrays Bay, Auckland, New Zealand	157.11	''	03/07/00
Mr Albert Henry E. Baldwin, Hillgate Oast Rolvenden Layne Cranbrook Kent, TN17 4PX United Kingdom	270.25	''	06/12/00
Ms Sheila Ballantyne ,71 Queens Grove, Lower Hutt, NZ	305.50	''	''
Banco Nominees Limited, Front Street, Hamilton, Bermuda	139.36	''	03/07/00
Ms Elizabeth Mary Barker, 55 Grey Street, St George, Qld	212.50	''	06/12/00
Ms Elizabeth Mary Barker, 55 Grey Street, St George, Qld	221.00	''	''
Mr Neil Gerard Barnden, 18 Barter Street, Whyalla, Playford, SA	1,243.32	''	03/07/00
Mr Neil Gerard Barnden, 18 Barter Street, Whyalla, Playford, SA	695.50	''	06/12/00
Mrs Margaret Agnes G. Barnett, 163 Waiwhetu Road, Lower Hutt, New Zealand	175.75	''	''
Mr Warwick Martin Barnett, 50 Racecourse Rd, Waiuku, NZ	125.00	''	''
Mrs Maria Barone & Miss Eleonara Barone & Mr Arnaldo Barone & Mrs Maura Pomazan, C/o 38 Jersey Street, Coburg	154.50	''	''
Mr Colin Barrie & Mrs Lynette Barrie, 218 Village Baxter, 8 Robinsons Road, Baxter	137.50	''	''
Mr Colin Barrie & Mrs Lynette Barrie, 218 Village Baxter, 8 Robinsons Road, Baxter	143.00	''	03/07/00
Mrs Lynette Blyth Barrie, PO Box 3102, Mildura	207.75	''	06/12/00
Mrs Lynette Blyth Barrie, PO Box 3102, Mildura	216.06	''	03/07/00
Mr Bede Barry, Apartment 2507, North Building, Jin Mao Gardens, 2515 Pu Dong Da Dao, Shanghai, China	156.81	''	''
Mr Michael S. Bastow, 15 John Street, Kew	610.25	''	06/12/00

<i>Victoria Government Gazette</i>	<i>G 38</i>	<i>19 September 2002</i>	<i>2481</i>
Mr Michael S. Bastow, 15 John Street, Kew	645.50	''	03/07/00
Miss Anne Elena Beaumont, 1/17 Awoonga Avenuem Koala Parkm Qld	159.00	''	06/12/00
Mr Gerald M. Behrens, Basement Flat 10A, Kempford Gardens, London SW5 United Kingdom	206.25	''	''
Mr Robert Alan Beischer, Bullock Creek Vineyard, 111 Belvoir Park Road, RSD Harcourt	170.00	''	''
Beng Choo Lim Medical Pty Ltd, "Superannuation Fund A/c", 12 Nilpina Street, Burnside SA	125.00	''	''
Mr Gregory Gordon Bennedick, 55 King Street, Moura, Qld	286.00	''	03/07/00
Mr Gregory Gordon Bennedick, 55 King Street, Moura, Qld	275.00	''	06/12/00
Mrs Catherine Margaret Bennet, 143 Main St,Bacchus Marsh	172.90	''	03/07/00
Mrs Catherine Margaret Bennet, 143 Main St,Bacchus Marsh	166.50	''	06/12/00
Mr Torix Peter Bennett, C/o Kinsey Bennett & Gill, 127 Creek Street, Brisbane, Qld	753.25	''	''
Mr Paul Bernie & Mrs Bronwyn Edwards, "Bernie Family A/c",36 Leysdown Ave, North Rocks, NSW	250.00	''	''
Mr Paul Bernie & Mrs Bronwyn Edwards, "Bernie Family A/c",36 Leysdown Ave, North Rocks, NSW	260.00	''	03/07/00
Mr Paul Bernie, "Bernie Family A/c", 36 Leysdown Avenue, North Rocks NSW	250.00	''	06/12/00
Mr Paul Bernie, "Bernie Family A/c", 36 Leysdown Avenue, North Rocks NSW	260.00	''	03/07/00
Mr David Walter Harold Berry, PO Box 56-004, Linden Post Office, Tawa, New Zealand	2,042.30	''	''
Mr David Walter Harold Berry, PO Box 56-004, Linden Post Office, Tawa, New Zealand	1,963.75	''	06/12/00
Dr Paul Randolph Berry, 1 Erin St, Roslyn, Dunedin, NZ	2,187.00	''	''
Dr Paul Randolph Berry, 1 Erin St, Roslyn, Dunedin, NZ	2,274.48	''	03/07/00
Est Late Marcelle Joy Bertol, C/o Public Trustee, Box M946, Perth, WA	102.31	''	''
Mrs Joyce Bettridge, 137 Abbett Street, Scarborough, WA	157.75	''	06/12/00
Mrs Joyce Bettridge, 137 Abbett Street, Scarborough, WA	164.06	''	03/07/00
Mr James Joseph Bidner, 17/5 Queensland Avenue, Broadbeach, Qld	154.18	''	''
Mr James Joseph Bidner, 17/5 Queensland Avenue, Broadbeach, Qld	148.25	''	06/12/00
Mr David Price Billington, PO Box 470, Bridgetown, WA	103.72	''	03/07/00
Mr David Price Billington, PO Box 470, Bridgetown, WA	100.00	''	06/12/00
Mr James Mcpherson Billson, 56 Park Street, North Fitzroy	138.84	''	03/07/00
Miss Linda Murray Bingham, Castle Hill, Inverness, UK	371.75	''	06/12/00
Miss Linda Murray Bingham, Castle Hill, Inverness, UK	338.50	''	''
Mrs Audrey Bisgood, The Garden House, Little Newtown, Enniskerry Co, Wicklow, Eire	233.48	''	03/07/00
Mrs Felicity Anne Bisiani, 3/5 Gordon Street, Toorak	125.00	''	06/12/00
Mrs Christina M. Blackall, 2 Oak Street, Surrey Hills	376.00	''	''
Mr Peter Murray Blackwell, 211 Alfred St, Cromer, NSW	453.11	''	03/07/00
Mr Vincent Blagotinsek, 4 Finlay Street, Cooke Point, WA	736.32	''	''
Mrs Fiona Margaret Blanch, 50 Kinkora Road, Hawthorn	110.00	''	06/12/00
Est Late Gwenneth May Boanas, C/o R. Burt & A. Logan, PO Box 3021, Christchurch, NZ	218.50	''	''
Mr David John Boell, 32 Caithness Crescent, Glen Waverley	204.50	''	''

2482 G 38 19 September 2002

Victoria Government Gazette

Est Late Valentina Bogdan, C/o Gerrard Limited, 155 St Vincent Street, Glasgow G2 5NN United Kingdom	244.75	”	”
Mrs Robin Ann Bolin, 1/43 St Marks Rd, Randwick, NSW	1,135.25	”	”
Mrs Robin Ann Bolin, “A/c 2”, 1/43 St Marks Road, Randwick, NSW	854.75	”	”
Mr John Bryan Bond & Mrs Geraldine Kathleen Bird, 148 Forrest Street, Peppermint Grove, WA	188.50	”	”
Mr Jamie Bonic, 4/42 Marcel Avenue, Randwick, NSW	106.53	”	03/07/00
Mr Raymond Alan Bonner, 4/46 Mindarra Drive, Newman, WA	125.00	”	06/12/00
Mr Raymond Alan Bonner, 4/46 Mindarra Drive, Newman, WA	130.00	”	03/07/00
Mrs Gloria Ann Booth, Villa 1, 56 Tiral Street, Charlestown, NSW	205.50	”	06/12/00
Ms Jo-Anne Vendra Borg, 400 Wilowood Road, Bulla	256.75	”	”
Mrs Imelda Bourke, 4/40 Marine Parade, St Kilda	163.80	”	03/07/00
Mrs Imelda Bourke, 4/40 Marine Parade, St Kilda	157.50	”	06/12/00
Mr Robert Neil Bowen, PO Box 131, Capel, WA	528.89	”	03/07/00
Mr Robert Neil Bowen, PO Box 131, Capel, WA	499.75	”	06/12/00
Mr David Ewen Boyd, 57 First Avenue, Kew East	100.75	”	”
Mr Stuart Arnold Boydell, PO Box 84, Erskineville, NSW	259.37	”	03/07/00
Brading Nominees Pty Ltd, “Anthea Crawford S/F A/c”, 47 O’Grady Street, Albert Park	573.30	”	”
Brading Nominees Pty Ltd, “Anthea Crawford S/F A/c”, 47 O’Grady Street, Albert Park	551.25	”	06/12/00
Ms Rebecca Jane Branch, 2/593 Manukau Road, Epsom, Auckland, New Zealand	161.25	”	”
Ms Rebecca Jane Branch, 2/593 Manukau Road, Epsom, Auckland, New Zealand	167.70	”	03/07/00
Mr Jacques Junion-Brasseur, Rue De La Bruyere, St Martin 51 1320 Tourinnes-La-Grosse, Belgium	122.46	”	”
Mrs Jessie Annette Brennan, 1 Casey Court, Moranbah, Qld	164.84	”	”
Mrs Jessie Annette Brennan, 1 Casey Court, Moranbah, Qld	158.50	”	06/12/00
Mr Erick Michael Brenstrum, 10 Elphinstone Avenue, Strathmore, Wellington, NZ	124.80	”	03/07/00
Mr Erick Michael Brenstrum, 10 Elphinstone Avenue, Strathmore, Wellington, NZ	120.00	”	06/12/00
Mr James Harold Brewster, 27/8 Giles Street, Kingston, ACT	152.52	”	03/07/00
Mr James Harold Brewster, 27/8 Giles Street, Kingston, ACT	147.25	”	06/12/00
Est Late Arnold W. Bridges, PO Box 184, Huntingdale	800.08	”	03/07/00
Est Late Arnold W. Bridges, PO Box 184, Huntingdale	766.00	”	06/12/00
Est Late Ernest E. T. Brimage, C/o Mr Russell E. Brimage, PO Box 941, Nedlands, WA	171.60	”	03/07/00
Mr Frank John Briner, 23 Ulupna Road, Ormond	133.50	”	06/12/00
Mr Eric Brokken, 9 Litchfield Street, Whyalla, Norrie, SA	156.00	”	03/07/00
Mr George Brook, 15/94–96 Mount Street, Coogee, NSW	577.50	”	06/12/00
Mr George Brook, 15/94–96 Mount Street, Coogee, NSW	600.60	”	03/07/00
Mr Donald Herbert Brooks, 3 Sedgman St, Moranbah, Qld	165.64	”	”
Mr Donald Herbert Brooks, 3 Sedgman St, Moranbah, Qld	159.50	”	06/12/00
Mr Tim Brotherton, 7/14 Kidman Street, Coogee, NSW	459.00	”	”
Mr Tim Brotherton, 7/14 Kidman Street, Coogee, NSW	477.64	”	03/07/00
Ms Angela Margaret Brown, C/o Swanban Pty Ltd, 60 Golden Grove, Beacon Hill, NSW	361.23	”	”

Mrs Audrey Iris Brown, 35 Orchard Close, New Barn, Longfield Dartford, Kent DA3 7JP UK	409.50	''	06/12/00
Mr Graeme Arthur Brown, 6B Mansfield St, Greta, NSW	500.00	''	''
Mr Jeffrey Ian Brown, 3 Somerville Street, Bulli, NSW	100.00	''	''
Mr Jeffrey Ian Brown, 3 Somerville Street, Bulli, NSW	104.00	''	03/07/00
Mr Maurice Lloyd Brown, 330 Hill St, Richmond, Nelson, NZ	352.56	''	''
Mr Maurice Lloyd Brown, 330 Hill St, Richmond, Nelson, NZ	339.00	''	06/12/00
Mr Percy Brown & Mr Gerald David Adlestone, 16 St Annes Road, West St Annes-On-Sea Lancs, FY8 1RE UK	411.75	''	''
Mr Roger William Brown, PO Box 5, Lyneham, ACT	270.19	''	03/07/00
Mr Roger William Brown, PO Box 5, Lyneham, ACT	256.75	''	06/12/00
Mr Ross David Brown, 3 Pambula Place, Forestville, NSW	126.25	''	''
Ms Sally Louise Brown & Ms Jennifer Audrie Collins & Ms Phyllipa Jane Shaw, C/o Le Pine & Co, PO Box 140, Taupo, New Zealand	130.00	''	03/07/00
Bruce Ewen Nominees Pty Ltd, "Ewen Family A/c", 225 The Esplanade, Altona	354.50	''	06/12/00
Ms Donnella Bryce, 122 Provincial Road, Lindfield, NSW	181.00	''	''
Mrs Evelyn Grace Buckley, PO Box A2105, Sydney South, NSW	1,840.75	''	''
Mrs Evelyn Grace Buckley, PO Box A2105, Sydney South, NSW	1,914.38	''	03/07/00
Mr John Mark Budge & Mr James Waldron, 2/24 Honiton Avenue, Carlingford, NSW	102.25	''	06/12/00
Mr Keith Burston & Mrs Jill Burston, 61 Brisbane Street, Mackay, Qld	101.00	''	06/12/00
Ms Mary Anne Teresa Burston, PO Box 1464, Traralgon	102.25	''	''
Mr John William Burton, 157 Dunbar St, Stockton, NSW	1,151.67	''	03/07/00
Mr John William Burton, 157 Dunbar St, Stockton, NSW	1,098.25	''	06/12/00
Mrs Louise Butter Buckatree Farm The Wrekin Wellington Telford Shropshire TF6 5AL UK	121.00	''	''
Est Late William A. Butterss, C/o Shinkfield Financial Services, PO Box 2626, Cheltenham	763.75	''	''
Mr R. Mark Byers, Waterfoot House, Newcastle, Co Down, United Kingdom	392.75	''	''
Mr Max Walter Bygraves, 32 Stafford Mansions, Stafford Place, London SW1 UK	137.50	''	''
Mr May Walter Bygraves, 110 Roebuck House, Stag Place, London, United Kingdom	439.75	''	''
Mr John Thomas Byrne, 21 Verge Place, West Hoxton, NSW	182.00	''	''
The Rt Hon Robert James Byron, 19 Spencer Park, Wandsworth, London SW18 2SZ UK	750.00	''	''
Mrs Joanna Penelope Cacasnas, Upper Swainswick House, Upper Swainswick, Bath Avon BA1 8BU UK	370.75	''	''
Est Late Alessandro Caccavo & Mr Charles Rex Garity, "Paul Caccavo Family A/c", C/o Garity Hurd & Partners, 110 Hampden Road, Battery Point, Tas.	109.25	''	''
Mr David Ronald Cameron, 193 Chuculba Crescent, Giralang, ACT	286.00	''	03/07/00
Ms Hannah Christine Cameron, 15 Saunders Street, Swanbourne, WA	228.80	''	''
Mr Peter Robert Cameron, 26 Cambridge St, Red Hill, Qld	124.50	''	06/12/00
Mr Bruce C. Campbell, 2/47 Hamilton Road, Hataitai, Wellington, NZ	193.17	''	03/07/00

2484 G 38 19 September 2002

Victoria Government Gazette

Mr Tino Campesato & Ms Lorraine Berra, "Ramsay Superannuation A/c", 5 Ramsay Avenue, East Kew	187.25	"	06/12/00
Mr Ewan Cantrill, PO Box 176, Eastwood, NSW	242.00	"	"
Mr Ewan Cantrill, PO Box 176, Eastwood, NSW	251.56	"	03/07/00
Ms Veryan Anne Caravelas, "Gwandalan", Hawkins Lane, Bolwarra Via Portland	143.52	"	"
Carlton NZ Ltd, 44 McFarlane Street, Wellington, NZ	131.00	"	06/12/00
Carlton NZ Ltd, 44 McFarlane Street, Wellington, NZ	136.36	"	03/07/00
Carmtone Investments Pty Ltd, "Everton House", 1 Everton Road, Faulconbridge, NSW	133.90	"	"
Carmtone Investments Pty Ltd, "Everton House", 1 Everton Road, Faulconbridge, NSW	128.75	"	06/12/00
Mrs Heather Dawn Carpenter, 154 Hague Crescent, Iron Knob, SA	117.81	"	03/07/00
Mrs Heather Dawn Carpenter, 154 Hague Crescent, Iron Knob, SA	112.25	"	06/12/00
Est Late William E. Carpenter, C/o Mrs Heather D. Carpenter, 154 Hague Crescent, Iron Knob, SA	109.20	"	03/07/00
Est Late William E. Carpenter, C/o Mrs Heather D. Carpenter, 154 Hague Crescent, Iron Knob, SA	105.00	"	06/12/00
Mrs Bettie Carson, 1 Wackett Street, Maroubra, NSW	125.00	"	"
Cartaban Malaya Nominees, Sendirian Berhad, PO Box 13150, Kuala Lumpur, Malaysia	454.22	"	03/07/00
Mr John B. Carthew, 1/11 Cedar Court, Burleigh Heads, Qld	228.25	"	06/12/00
Mr John B. Carthew, 1/11 Cedar Court, Burleigh Heads, Qld	237.38	"	03/07/00
Mr Robert John Cartledge, 3 The Close, Frankston	471.50	"	06/12/00
Mr Scott Fraser Cartledge, 14 Harper St, Port Hedland, WA	129.00	"	"
Miss Sarah Anne Caska, PO Box 54, Woy Woy, NSW	233.00	"	"
Mr Robert Vincent Castle, Clifton House, Langley End, Hitchin Herts SG4 7PT UK	106.00	"	"
Castlefolds Nominees Limited, "J028 A/c", Beech House, 61 Napier Street, Sheffield S11 8AA UK	149.25	"	"
Mr Gregory John Catlin, 37 Peebles Road, Floreat, WA	213.50	"	"
Mr Gregory John Catlin, 37 Peebles Road, Floreat, WA	220.95	"	03/07/00
Mr Michael Damian Caveny & Mr Peter John Caveny & Mr Patrick Thomas Caveny, "Est M. Caveny A/c", PO Box 104, Moe	113.58	"	"
Cedley Pty Ltd, "Cedley Superfund A/c", C/o Gibbs Surrey, 17th Floor, 500 Collins Street, Melbourne	178.27	"	"
Mrs Mavis Joyce Chalmers, 49 Garling St, Lane Cove, NSW	897.25	"	06/12/00
Mrs Mavis Joyce Chalmers, 49 Garling St, Lane Cove, NSW	933.14	"	03/07/00
Chambers Music Pty Limited, "Superannuation Fund A/c", C/o G. War, PO Box 477, St Leonards, NSW	179.89	"	"
Chambers Music Pty Limited, "Superannuation Fund A/c", C/o G. War, PO Box 477, St Leonards, NSW	158.75	"	06/12/00
Mr Peter Nam Kuan Chan, 2 Hillcrest Road, Glen Iris	129.00	"	"
Mr Peter Nam Kuan Chan, 2 Hillcrest Road, Glen Iris	133.90	"	03/07/00
Mrs Julie Jane Chandler, PO Box 225, Hawthorn	160.00	"	06/12/00
Mrs Julie Jane Chandler, PO Box 225, Hawthorn	166.40	"	03/07/00
Mr Lawrence Frederick Chappell & Mrs Judith Emily Chappell, 2 Bapaume Rd, Mosman, NSW	341.75	"	06/12/00

Mr John Edward Chatterton & Mrs Adrienne Mary Chatterton, 1/49 Stewart St, Manly NSW	211.50	''	''
Mrs Geit Hong Cheah, 503 Victoria Ave, Chatswood, NSW	135.57	''	03/07/00
Mr Bo Fong Cheng, 116 Koongara Rd, Roseville Chase, NSW	187.72	''	''
Mr Bo Fong Cheng, 116 Koongara Rd, Roseville Chase, NSW	180.50	''	06/12/00
Mrs Melinda Joy Chester, 7 Awaba Street, Eaglemont	130.00	''	03/07/00
Miss Mary-Ann Quee Fung Chiam, 87 University Road, Singapore	670.03	''	''
Mrs Toni Rhonda Chiplin, 68 Castle Circuit, Seaforth, NSW	118.00	''	06/12/00
Mrs Toni Rhonda Chiplin, 68 Castle Circuit, Seaforth, NSW	122.72	''	03/07/00
Mr Siu Ming Dominic Chiu, Flat D, 10/F Yat Tien Mansion, Taikoo Shing, Hong Kong	125.00	''	06/12/00
Mrs Khoo G. Choo, 113 Jalan Wangsa Satu Wangsa Ukay off Ulu Kelang 68000 Selangor, Malaysia	172.30	''	03/07/00
Mrs Khoo G. Choo, 113 Jalan Wangsa Satu Wangsa Ukay off Ulu Kelang 68000 Selangor, Malaysia	162.50	''	06/12/00
Mrs Thea Clark, C/o J. A. McKay, 10/16 Woorigoleen Road, Toorak	308.25	''	''
Mrs Thea Clark, C/o J. A. McKay, 10/16 Woorigoleen Road, Toorak	324.00	''	03/07/00
Mr Kenneth C. Clay, Gundimore House, 171 Mundeford, Christchurch, Dorset BH23 4AG UK	187.50	''	06/12/00
Mrs Dorothy Maude Cleland, C/o Winchmore 22 Darling Street, Medindie, SA	113.75	''	''
Clemco Estates Pty Limited, PO Box 606, Artarmon, NSW	176.50	''	''
Clemco Estates Pty Limited, PO Box 606, Artarmon, NSW	183.56	''	03/07/00
Mrs Deborah Gertrude Clipsham, The Hermitage, Norwich Road, Edgefield Melton Constable Norfolk NR24 2AL UK	280.75	''	06/12/00
Clitheroe Pty Ltd, "Clitheroe Family A/c", 3 Huntleys Point Road, Huntleys Point, NSW	129.00	''	''
Clydesdale Bank Head Office Nominees Limited, 30 St Vincent Place, Glasgow G1 2HL United Kingdom	100.00	''	''
Ms Lyndal R. Coates, 36 Taleeban Road, Lane Cove, NSW	164.75	''	''
Mr Christopher John Coburn, 9 Chatfield Avenue, Balwyn	118.75	''	''
Mr Alan Thomas Cole, 33 Morgan Ave, Mt Warrigal, NSW	125.00	''	''
Miss Alison Ruth Cole 37 The Tor Walk Castlecrag NSW	217.75	''	''
Dr John Houghton Colebatch & Est Late Beatrice B. Colebatch, 1 Henty Court, Kew	172.00	''	''
Dr John Houghton Colebatch & Est Late Beatrice B. Colebatch, 1 Henty Court, Kew	178.88	''	03/07/00
Mrs Fatima Colic, 40 Invermore Close, Elernmore Vale, NSW	275.00	''	06/12/00
Mrs Fatima Colic, 40 Invermore Close, Elernmore Vale, NSW	286.00	''	03/07/00
Mr Peter Quirino Colleluori, 295 Jells Road, Mulgrave	100.00	''	06/12/00
Ms Anita Faye Collis, 20 Henry Street, Windsor	142.50	''	''
Miss Kathleen Mary Commins, C/o Mr C. A. P. Munro, 66 Johnson Street, Chatswood, NSW	242.84	''	03/07/00
Ms Maryann Connolly, 2/669 Military Road, Mosman, NSW	149.44	''	03/07/00
Est Late Michael B. Conran, C/o Ronald Fletcher & Co, 243 Elgin Avenue, Maida Vale, London W9 1NJ UK	156.75	''	06/12/00
Mr James Joseph Conroy, PO Box 101, Blayney, NSW	155.50	''	''
Mr James Joseph Conroy, PO Box 101, Blayney, NSW	161.72	''	03/07/00
Mrs Anne Elizabeth Cook, 46 Louisa Rd, Birchgrove, NSW	105.00	''	06/12/00

2486 G 38 19 September 2002

Victoria Government Gazette

Mrs Anne Elizabeth Cook, 46 Louisa Rd, Birchgrove, NSW	109.20	''	03/07/00
Mr Kenneth John Cooke, PO Box 34B, Potts Point, NSW	263.12	''	''
Mr Kenneth John Cooke, PO Box 34B, Potts Point, NSW	253.00	''	06/12/00
Mrs Robin Joan Cooke, 19 Rothwell Crescent, Lane Cove, NSW	468.00	''	''
Miss Janette Rose Cooper, PO Box 10, Flemington	407.31	''	03/07/00
Mr Wilfred Walter H. Cornille & Mrs Nelly Maertens, Ringlaan Noord 70 De Haan, Belgium	1,191.06	''	''
Mr Bryan David Cornish, 7 Belshore Street, Moranbah, Qld	260.00	''	''
Mr Bryan David Cornish, 7 Belshore Street, Moranbah, Qld Corpak Constructions Pty Limited,	250.00	''	06/12/00
“Corpak Super Fund A/c”, PO Box 684, Bathurst, NSW	190.84	''	03/07/00
Mr Paddy Costigan, 15/27 Dickens Street, Elwood	266.00	''	06/12/00
Mr Paddy Costigan, 15/27 Dickens Street, Elwood	276.10	''	03/07/00
Mr Tim Costigan, Clyde Park, Old Highway, Glenrowan	112.84	''	''
Mr Tim Costigan, Clyde Park, Old Highway, Glenrowan	108.50	''	06/12/00
Mr Goce Costovschi, 13 Bottlebrush Ave, Medowie, NSW	136.50	''	''
Mr William M. Coulson, 3 Cypress Street, Echuca	155.25	''	''
Mr Malcolm John Coulston 24 Mitchell Street Brunswick	125.00	''	''
Dr Patricia Anne Coulton 87 Liddiard Street Hawthorn	157.30	''	03/07/00
Miss Wilma M. Courthope, C/o P. J. Tracey, GPO Box 1220M, Hobart, Tas.	353.25	''	06/12/00
Miss Wilma M. Courthope, C/o P. J. Tracey, GPO Box 1220M, Hobart, Tas.	367.38	''	03/07/00
Miss Belinda Alice T. Coy, RMB 1525, Camperdown	200.72	''	''
Miss Belinda Alice T. Coy, RMB 1525, Camperdown	193.00	''	06/12/00
Miss Kathleen S. L. Cresswell, 6 Greenhills Road, Charlton Kings, Cheltenham, Glos GL53 9ED UK Est Late Ralph Cridland,	787.00	''	''
C/o David R. Jarrett, PO Box 154, Bangor, NSW	142.75	''	''
Mrs Margaret J. Crittenden, PO Box 464, Dromana	250.00	''	''
Mrs Annabel Rosalind Cropper, “Greenhills”, Willow Tree, NSW	105.00	''	''
Mrs Annabel Rosalind Cropper, “Greenhills”, Willow Tree, NSW	108.77	''	03/07/00
Mr Alan Lynton Crouch, Top Flat, 32 Southholm Street, Battersea Park, London SW11 SEZ United Kingdom	186.00	''	06/12/00
Mr David John Cruickshank, 185 Dorville Rd, Carseldine, Qld	107.72	''	03/07/00
C. S. Nominees, Sdn Bhd, PO Box 522-30750 Ipoh, Malaysia	126.88	''	''
C. S. Nominees, Sdn Bhd, PO Box 522-30750 Ipoh, Malaysia	122.00	''	06/12/00
C. T. Tan Superannuation Pty Ltd, “CT Tan Family Super A/c”, 3 Bindaring Parade, Claremont, WA	1,250.00	''	''
Mr David Alastair T. Cullen, Cherry Tree Cottage, Fyning Lane, Rogate, Petersfield GU31 5DQ UK	151.75	''	''
Mr Michael Robert A. Cullen, 8 Blenheim Terrace, Bovey Tracey Devon TQ13 9AT United Kingdom	152.00	''	''
Mrs Jean Margaret Cunningham, Larchwood East, Peaston NR Ormiston East, Lothian EH35 5NL UK Est Late Hazel Joan Cunnison,	188.00	''	''
C/o Raphael Zorn Hemsley Ltd, Cheapside House, 138 Cheapside, London EC2V 6LH UK	371.00	''	''
Mr Frank Anthony Curcio & Mr Mario Costa, 268 Wingrove Street, Fairfield	310.14	''	03/07/00

Mr Frank Anthony Curcio & Mr Mario Costa, 268 Wingrove Street, Fairfield	298.50	''	06/12/00
Miss Jodie Anne Custance, 11 Newry Street, Richmond	208.25	''	''
Miss Jodie Anne Custance, 11 Newry Street, Richmond	216.58	''	03/07/00
Est Late Vera S. Cuthbertson, C/o Andrews, Level 2, 34 Burton Street, Kirribilli, NSW	286.00	''	''
Dahia Pty Ltd, PO Box 239, Box Hill	213.50	''	06/12/00
Dahia Pty Ltd, PO Box 239, Box Hill	220.95	''	03/07/00
Mr Denis Dalcin, 37 Quinlan Avenue, St Marys, SA	130.00	''	''
Mr Denis Dalcin, 37 Quinlan Avenue, St Marys, SA	125.00	''	06/12/00
Mr Andrew Grant Dalton, Arundel Farm Rd, Bombay, NZ	118.62	''	03/07/00
Mr Andrew Grant Dalton, Arundel Farm Rd, Bombay, NZ	112.25	''	06/12/00
Mr Brian Dalton, 25 Eraldoure Street, North Caulfield	101.31	''	03/07/00
Mr Sean Patrick Daly, 6 Janelle Court, Andergrove, Qld	125.00	''	06/12/00
Dr Geoffrey Cameron Darby, 49 Virginia Street, Newtown	1,323.50	''	''
Dr Geoffrey Cameron Darby, 49 Virginia Street, Newtown	1,376.44	''	03/07/00
Mrs Fusae Dargan & Mr Raymond John Dargan, 4A/5 Girilang Avenue, Vacluse, NSW	158.75	''	06/12/00
Mrs Fusae Dargan & Mr Raymond John Dargan, 4A/5 Girilang Avenue, Vacluse, NSW	179.89	''	03/07/00
Mr David Charles Davidson, 66 Marlborough St, Malvern, SA	164.75	''	06/12/00
Mrs Poh Pheng Davies, Apartment 906, "The Marbury", 174-182 Goulburn St, Surry Hills, NSW	133.25	''	''
Mr Robert Bruce Davies, PO Box 561, Lithgow, NSW	187.09	''	03/07/00
Miss Barbara Patricia Davis, 103/188 Chalmers Street, Surry Hills, NSW	160.25	''	06/12/00
Miss Barbara Patricia Davis, 103/188 Chalmers Street, Surry Hills, NSW	166.66	''	03/07/00
Davjin Pty Ltd, "A/c SF", C/o C. G. Landy Services Pty, GPO Box 968G, Melbourne	545.02	''	''
Davjin Pty Ltd, "A/c SF", C/o C. G. Landy Services Pty, GPO Box 968G, Melbourne	522.25	''	06/12/00
Dr Peter Edgar R. Dawson, PO Box 18, Campbell, ACT	212.50	''	''
Mrs Pauline Ashenden Deakins, 68 Rednal Street, Mona Vale, NSW	200.00	''	''
Mr Christopher Jeffrey Dean, 6/1 Gray Court, Karratha, WA	201.50	''	''
Mrs Joan Dean Dunsmore, Fallowfield, Blagdon Bristol, Avon, United Kingdom	128.75	''	''
Mrs Marianne Louise De Giorgio, 12 Lena Gardens, London W6 7PZ United Kingdom	443.75	''	''
Mrs Diana E. De Hauteclocque, 59A Bellevue Road, Bellevue Hill, NSW	112.11	''	03/07/00
Mr Robert Anthony De Nicolo, 3/27 Hampton Road, West Essendon	125.00	''	06/12/00
Denim Tower Pty Ltd, PO Box 373, Hawthorn	114.40	''	03/07/00
Denim Tower Pty Ltd, PO Box 373, Hawthorn	110.00	''	06/12/00
Ms Claire Elizabeth Dennis, 28 Tower Road, North Balwyn	136.00	''	''
Ms Claire Elizabeth Dennis, 28 Tower Road, North Balwyn	148.06	''	03/07/00
Miss Sarah Lucy Deverell, 38 Rotherfield Road, Henley-On-Thames, Oxfordshire RG9 1NN UK	334.50	''	06/12/00
Mr Mark Robert Devereux, 29 Strickland Rd, Ardross WA	363.75	''	''
Mr David John Devers, 68 Cecil Street, Williamstown	198.29	''	03/07/00
Mr David John Devers, 68 Cecil Street, Williamstown	186.25	''	06/12/00

2488 G 38 19 September 2002

Victoria Government Gazette

Est Late Gregory Leonard Devin, C/o Mr L. Devin, PO Box 1215, Noosaville, Qld	303.50	''	''
Est Late Gregory Leonard Devin, C/o Mr L. Devin, PO Box 1215, Noosaville, Qld	329.28	''	03/07/00
Mr Hendrik Johannes De Windt, 62/22–26 Corrimal Street, Wollongong, NSW	215.85	''	''
Mr Hendrik Johannes De Windt, 62/22–26 Corrimal Street, Wollongong NSW	208.50	''	06/12/00
Mr Blagoja Dimovski, 5 Deenyi Close, Cordeaux Heights, NSW	321.50	''	''
DMH Mediation Pty Limited, “Superannuation Fund Account”, 28 Collins Street, Narrabeen, NSW	129.00	''	''
Mr Robert Michael Dodgson, 137 Doncaster Avenue, Kensington, NSW	152.00	''	''
Mr Robert Michael Dodgson, 137 Doncaster Avenue, Kensington, NSW	157.81	''	03/07/00
Miss Margaret Mei Ling Doery, Apartment 7, 568–590 Lygon Street, Carlton	260.00	''	''
Miss Margaret Mei Ling Doery, Apartment 7, 568–590 Lygon Street, Carlton	250.00	''	06/12/00
Mrs Doris Sybil Donnan, Villa 6, Rothwood Gardens, 454/458 Moss Vale Road, Bowral, NSW	375.49	''	03/07/00
Dr Christopher Ferier Donovan, 25 Middleway, Hampstead Garden, Suburb London N W 11 UK	1,990.75	''	06/12/00
Mr David Raymond Dooley & Mr Allan David Dooley & Ms Bronwyn Marie Ellen Dooley, “Stephen John Dooley A/c”, 86 The Eyrie, Eaglemont	112.25	''	''
Est Late Mollie Joan Dooley & Mr Allan David Dooley & Mrs Bronwyn Marie Ellen Dooley 86 The Eyrie, Eaglemont	696.25	''	''
Mrs Dorothy Jean Dore, 7 Margaret Street, Canterbury	272.50	''	''
Mrs Dorothy Jean Dore, 7 Margaret Street, Canterbury	283.40	''	03/07/00
Dosway Pty Limited, “S F A/c”, 9/38 Francis Street, Castle Hill, NSW	129.75	''	06/12/00
Dosway Pty Limited, “S F A/c”, 9/38 Francis Street, Castle Hill, NSW	134.94	''	03/07/00
Mr Leonard Alan Douglas, 8 Perry Place, Kiama Downs, NSW	197.50	''	06/12/00
Mr Leonard Alan Douglas, 8 Perry Place, Kiama Downs, NSW	212.93	''	03/07/00
Mrs Jing Fen Dousha, 24/19–25 Pile St, Marrickville, NSW	147.30	''	''
Mrs Jing Fen Dousha, 24/19–25 Pile St, Marrickville, NSW	142.00	''	06/12/00
Mr Mark Richard Drew, 7 University Walk, University Park, Singapore	150.00	''	''
Est Late Marie V. Dudley, C/o Mr J. Dudley, 47 Pentecost Avenue, Pymble, NSW	264.72	''	03/07/00
Est Late Marie V. Dudley, C/o Mr J. Dudley, 47 Pentecost Avenue, Pymble, NSW	248.75	''	06/12/00
Mr Alan Sutherland Duncan, PO Box 282, Te Kuiti, NZ	597.00	''	''
Mr Alan Sutherland Duncan, PO Box 282, Te Kuiti, NZ	620.88	''	03/07/00
Mrs Hilda Dunnett 22 Sunningdale Street Morley WA	200.20	''	''
Mrs Anna Dunsheath, PO Box 4181, Auckland, NZ	123.25	''	06/12/00

Mr Stewart Geoffrey East & Mr Maxwell James Graham, C/o Ernest & Whinney, GPO BOX 1996, Canberra, ACT	424.61	''	03/07/00
Mr Stewart Geoffrey East & Mr Maxwell James Graham, C/o Ernest & Whinney, GPO BOX 1996, Canberra, ACT	402.25	''	06/12/00
Eaton Management Services Pty Ltd, "Eaton Mgt Srvs S/F A/c", PO Box 471, Woollahra, NSW	197.75	''	''
Miss Niki Ebacioni, 45 Anderson Street, Heidelberg	121.42	''	03/07/00
Miss Niki Ebacioni, 45 Anderson Street, Heidelberg	116.75	''	06/12/00
Est Late Walter Allison Ebdon, 14 Bamboo St, Nightcliff, NT	125.00	''	''
Mrs Jacqueline Ecker, 107 Military Rd, Dover Heights, NSW	217.75	''	''
Mrs Jacqueline Ecker, 107 Military Rd, Dover Heights, NSW	226.46	''	03/07/00
Mrs Iris Edelman, 77 Cutler Road, Clontarf, NSW	893.41	''	03/07/00
Mr Chad Nathan Edgar, 1/38 Virginia Street, North Wollongong, NSW	146.00	''	06/12/00
Mr John Alexander Edgar, 1/173 Ormond Road, Elwood	485.50	''	''
Mrs Meridith Joy Edgar, 1/173 Ormond Road, Elwood	485.50	''	''
Miss Susan Mary Edward, 39 Curl Curl Parade, Curl Curl, NSW	128.75	''	''
Elbaton Holdings Pty Limited, C/o Mrs I. M. Beston, 48 Olala Avenue, Vaucluse, NSW	153.25	''	''
Mrs Gabrielle Joyce Ellerm, 426 Riddell Road, Glendowie, Auckland, New Zealand	155.75	''	''
Mr Oswald John Ellis, 4 Shipley Road, Blackheath, NSW	236.21	''	03/07/00
Mr Oswald John Ellis, 4 Shipley Road, Blackheath, NSW	227.25	''	06/12/00
Mr Ian Elliss & Mrs Mary Millington & Mrs Margaret Woods, "Est Alfred Lemessurier A/c", PO Box 194, Stepney, SA	388.30	''	03/07/00
Mr Henry Robinson Elsdale, C/o County Natwest Securities Aust Ltd, Level 15, 225 George Street, Sydney, NSW	127.98	''	''
Mr Henry Robinson Elsdale, C/o County Natwest Securities Aust Ltd, Level 15, 225 George Street, Sydney, NSW	123.25	''	06/12/00
Mrs Lucinda Esler, 9 Rotherwood Street, Richmond	814.84	''	03/07/00
Mrs Glenys Joy Euvrard, 276 South Road, Moorabbin	151.25	''	06/12/00
Mrs Glenys Joy Euvrard, 276 South Road, Moorabbin	157.30	''	03/07/00
Mr Allan William Evans, 26 Cahill Street, Dandenong	179.00	''	06/12/00
Mrs Lena Josephine Evans, 41/80 Outer Crescent, Brighton	208.50	''	''
Mrs Joan Elizabeth Evershed, 2 Chapman St, Bellerive, Tas.	1,272.50	''	''
Farquhar Associates Pty Ltd, PO Box 1062, Windsor	348.00	''	06/12/00
Mr Thomas William Fayle, 38 Caldwell Ave, Dudley, NSW	140.40	''	03/07/00
Mr Thomas William Fayle, 38 Caldwell Ave, Dudley, NSW	131.00	''	06/12/00
Mr Adrian M. Featherston, 3 Ian Grove, Burwood	1,955.00	''	''
Est Late Claire Featherston, 3 Ian Grove, Burwood	3,946.80	''	03/07/00
Featherstone Superannuation Pty Limited, 8 Longford Street, Roseville, NSW	130.00	''	''
Featherstone Superannuation Pty Limited, 8 Longford Street, Roseville, NSW	125.00	''	06/12/00
Est Late Evelyn V. Fedder, C/o Apears, GPO Box 4859, Sydney, NSW	2,551.25	''	''
Est Late Evelyn V. Fedder, C/o Apears, GPO Box 4859, Sydney, NSW	2,653.30	''	03/07/00

2490 G 38 19 September 2002

Victoria Government Gazette

Mr Stephen Michael Fenton & Miss Estelle Dianne Fenton, 20 March Street, Bellevue Hill, NSW	125.75	''	06/12/00
Mr Joseph C. Ferguson & Mrs Isabel A. Ferguson, 17 Conant Road, Weston MA 02493 USA	331.77	''	03/07/00
Mrs Ngaire Fifield, 2 Philip Place, Carlingford, NSW	103.00	''	06/12/00
Mr Brian Wheldon Finch, C/o D. I. Finch Parkwood Trust Inc, 39 Wren Street, Waikanae, New Zealand	490.36	''	03/07/00
Ms Fiona Fitzpatrick, 9/20 Pacific Street, Bronte, NSW	416.00	''	''
Ms Fiona Fitzpatrick, 9/20 Pacific Street, Bronte, NSW	400.00	''	06/12/00
Mr Benjamin David Fleay, RMB 7235, Buangor	414.12	''	03/07/00
Mr John Gibson Fletcher & Mr Ronald William Cashin & Mr Hugo Bentley Goetze "A/c Allen Trust", PO Box 2658, Canberra, ACT	323.00	''	06/12/00
Mr John Gibson Fletcher & Mr Ronald William Cashin & Mr Hugo Bentley Goetze, "A/c Allen Trust", PO Box 2658, Canberra, ACT	338.13	''	03/07/00
Mrs Judith Fletcher, Toft Monks, Lewis Lane, Chalfont, St Peter Bucks, United Kingdom	410.00	''	06/12/00
Miss Carmel M. Flis, PO Box 109, Sutherland, NSW	148.25	''	''
Miss Carmel M. Flis, PO Box 109, Sutherland, NSW	154.18	''	03/07/00
Mrs Bettina Yuen Seng Fong, 1 Embling Road, Malvern	293.75	''	06/12/00
Mrs Bettina Yuen Seng Fong, 1 Embling Road, Malvern	305.50	''	03/07/00
Mrs Barbara Mary Foo, C/o Mr Patrick Foo, Pt Orica Mining Services, Sentral Senayan 1 4th Floor, Jl Asia Afrika No 8 Jakarta, Indonesia	156.00	''	''
Dr Jennifer Kim Geok Foo, 17 Astrid Hill, Singapore	4,030.78	''	''
Mr Daryl Foote, "Andrew Johnson Foote A/c", 9 Octavia Court, Burwood	115.25	''	06/12/00
Est Late Margaret Jean Ford, C/o Ms Kathryn Constantin, 16A Junction Street, Cabramatta, NSW	1,527.00	''	''
Est Late Margaret Jean Ford, C/o Ms Kathryn Constantin, 16A Junction Street, Cabramatta, NSW	1,594.75	''	03/07/00
Mr Ronald Ford, 39 Creek Street, Walkerston, Qld	147.30	''	''
Mr Ronald Ford, 39 Creek Street, Walkerston, Qld	142.00	''	06/12/00
Est Late Angela C. Forster, C/o Bailhache Labesse, PO Box 207, St Helier Jersey JE1 1BD Channel Islands	3,318.00	''	''
Mr William Forsyth, Unit 14B, Salamander Bay Caravan Park, Soldiers Point Road, Salamander Bay, NSW	242.40	''	03/07/00
Mr Alessandro Fortini, 57 Eleanor Street, Rosehill, NSW	128.42	''	''
Mr Alessandro Fortini, 57 Eleanor Street, Rosehill, NSW	118.25	''	06/12/00
Mr Peter Anthony Yet Foy, 8 Barcoo Drive, Moranbah, Qld	302.50	''	''
Mr David Alan Franklin & Mrs Henrietta C. Franklin, C/- Smith Kline Beecham, Lvl 5, JMT Bldg, Adb Ave Ortigas Ctr Pasig Metro, Manila, Philippines	215.00	''	''
Mr David Alan Franklin & Mrs Henrietta C. Franklin, C/- Smith Kline Beecham, Lvl 5, JMT Bldg, Adb Ave Ortigas Ctr Pasig Metro, Manila, Philippines	223.60	''	03/07/00
Mr Raymond George Franklin, 19 Heatham Park, Twickenham, Middlesex TW2 7SF UK	520.25	''	06/12/00
Mr Ernest W. Frederick & Mrs Jeannette R. Frederick, 49 Hanby Road, Brighton	118.50	''	''

<i>Victoria Government Gazette</i>	<i>G 38</i>	<i>19 September 2002</i>	<i>2491</i>
Mr John Peter Freeman, 60 Sunnybank Road, Langwarrin	354.50	''	''
Dr Scott Fraser French, "Fraser Dental Svs S/F A/c", Suite 12, 18 Corinna Street, Phillip, ACT	146.50	''	''
Dr Scott Fraser French, "Fraser Dental Svs S/F A/c", Suite 12, 18 Corinna Street, Phillip, ACT	152.24	''	03/07/00
Mr Alan Friedman, "Est H. M. Friedman A/c", 1/12 Parkside Street, Elsternwick	396.75	''	06/12/00
Frinsdorf Investments Pty Ltd, Unit 8, 80 Barcom Avenue, Rushcutters Bay, NSW	258.00	''	''
Mrs Sierlah Janet Fryer, 46 Hailsham St, Alexandra Hills, Qld	711.10	''	03/07/00
Mr Sergio F. Fuenzalida, Americo Vespulio Sur #100, 9th Floor, Santiago, Chile	1,258.50	''	06/12/00
Mr Michael James Fursma, 5/25 Cajiput Way, Wickham, WA	142.00	''	''
Mr John Michael Galbraith, 22 Elsee Road, Rugby CV21 3BA UK	271.75	''	''
Galdeed Pty Ltd, "Khoo Family Fund A/c", 14 Alenola Street, Chapel Hill, Qld	206.00	''	''
Galdeed Pty Ltd, "Khoo Family Fund A/c", 14 Alenola Street, Chapel Hill, Qld	214.24	''	03/07/00
Mr Paul Gallo, "Disprax Superfund A/c", 119 Ferrars Street, Southbank	102.22	''	''
Mr Terence Anthony Gannon, PO Box 768, Sale	341.75	''	06/12/00
Mr John Garaty, 21 Rickard Road, Unanderra ,NSW	1,588.50	''	''
Mr James Russell Garbutt, 23 Athol Street, Toukley, NSW	269.10	''	03/07/00
Miss Carmel Mary Gaynor 45 Christowel Street, Camberwell	791.93	''	''
Ms Rosland Susan Jane Gellatly, Jackson's Road, R D 3 Blenheim, New Zealand	612.50	''	06/12/00
Ms Rosland Susan Jane Gellatly, Jackson's Road, R D 3 Blenheim, New Zealand	637.00	''	03/07/00
Mr Brenton Lee George, 12 Roundaway Crescent, O'Halloran Hill, SA	446.50	''	06/12/00
Gersor Pty Limited, 17 Chester Street, Oakleigh	137.50	''	''
Mr George Anthony Ghiocas, 10 Roxburgh St, Ascot Vale	103.50	''	''
Mr David Hume Gibbons, 4A Kowhai Grove, Waikanae, NZ	110.50	''	03/07/00
Mr Kurt Hunter Gibbons, 3 Carrathool Street, Griffith, NSW	105.20	''	''
Mrs Constance Maud Gibson, PO Box 6042, Riverview, Qld	137.50	''	06/12/00
Mrs Constance Maud Gibson, PO Box 6042, Riverview, Qld	143.00	''	03/07/00
Mr Eric Hermann Giersch, PO Box 661, Whyalla, SA	266.37	''	''
Mr Eric Hermann Giersch, PO Box 661, Whyalla, SA	256.75	''	06/12/00
Est Late Betty Lorraine Gilet, C/o Richardsons, 169 Macquarie Street, Parramatta, NSW	3,887.78	''	03/07/00
Est Late Betty Lorraine Gilet, C/o Richardsons, 169 Macquarie Street, Parramatta, NSW	3,738.25	''	06/12/00
Mr Anthony Edward Gilligan & Mrs Jennifer Robyn Gilligan, "A E G Super Fund A/c", PO Box 227, Mooloolaba, Qld	285.13	''	03/07/00
Mr Arthur Oswald M. Gilmour, Studio 15, Lifecare Centre 10/29 Gerard Way Meadowbank Auckland NZ	572.00	''	''
550.00	''	06/12/00	
Mrs Maxine Wendy Ginn 37 Cornwall Street Rose Bay Tas.	946.25	''	''
GJ & S Robinson Pty Ltd, "Super Fund A/c", 2 Ilma Court, Bulleen	250.00	''	''
Mrs Christine Glissan, 30 Wallaroy Road, Woollahra, NSW	113.76	''	03/07/00
Mrs Christine Glissan, 30 Wallaroy Road, Woollahra, NSW	109.50	''	06/12/00

2492 G 38 19 September 2002

Victoria Government Gazette

Global Engineering Pty Ltd, "HB Carson Super Fund A/c", 7 Landra Court, Grovedale	440.44	"	03/07/00
Global Engineering Pty Ltd, "HB Carson Super Fund A/c", 7 Landra Court, Grovedale	411.00	"	06/12/00
Mr James Bernard Godfrey, 14 Kemblawarra Road, Port Kembla, NSW	664.04	"	03/07/00
Mr Terence Keith Golding, 55 Government Road, Nelson Bay, NSW	347.39	"	"
Mr Terence Keith Golding, 55 Government Road, Nelson Bay, NSW	325.50	"	06/12/00
Ms Elizabeth Jane Goldstone, "A/c A. G. & A. Super Fund", 1/7 Cowderoy St, West St Kilda	181.50	"	"
Mr Peter William Goodhew, 25 Spencer Street, Summerhill, NSW	162.50	"	"
Ms Rosalind Ronan J. Goodier, 6 Victoria Road, Harborne, Birmingham B17 0AH UK	905.50	"	"
Mr Stephen Alfred Goodwin, 233 Kelvin Grove Road, Kelvin Grove, Qld	322.87	"	03/07/00
Mr Stephen Alfred Goodwin, 233 Kelvin Grove Road, Kelvin Grove, Qld	299.00	"	06/12/00
Mr Alan Leslie Gordon, 2/6 Beveles Ave, Unanderra, NSW	129.02	"	03/07/00
Mr Alan Leslie Gordon, 2/6 Beveles Ave, Unanderra, NSW	120.25	"	06/12/00
Ms Yvonne Gottsch, 52 Pacific Crescent, Maianbar, NSW	122.00	"	"
Mr Leonard Francis Gouge, 175 West Street, Glenroy	401.00	"	"
Mr William John Gow, Kyoma Llangothlin, NSW	698.62	"	03/07/00
Miss Kathleen Beulah Grace, C/o Clerk Walker & Stops, GPO Box 255C, Hobart, Tas.	2,295.00	"	06/12/00
Major John Graham, 12/14 The Borough, Crandall Farnham Surrey, United Kingdom	278.25	"	"
Grange Gate Limited, PO Box No 1017, Nassau, Bahamas	279.50	"	03/07/00
Mr John Charles MacDonald Grant & Mr Simon Boyd MacDdonald Grant, "The JCM Grant Super A/c", PO Box 7147, Riverside Centre, Brisbane, Qld	130.00	"	"
Dr Peter Wynne Grant, 116 Nymark Avenue, Willowdale, Ontario M2J 2H4 Canada	691.18	"	"
Mr Brian Richard Gray, 28 Cook Road, Killara, NSW	675.00	"	06/12/00
Dr John Robert Mager Gray & Mrs Robyn Ann Gray, "Gray Super Fund A/c", 38 Queens Avenue, Caulfield East	133.00	"	"
Mr Simon Edward Gray & Mr Toby James Gray, 74 Cameron Street, Edgecliff, NSW	173.50	"	"
Mr Simon Edward Gray & Mr Toby James Gray & Mrs Amy Catherine Gray, 74 Cameron St, Edgecliff, NSW	133.75	"	"
Mr Steven Robert Green, 25 Highland Parade, Bulli, NSW	100.00	"	"
Mrs Valerie Elizabeth Greene, C/o Mr JCM Grant, 1 Pullenvale Road, Pullenvale, Qld	286.00	"	03/07/00
Mrs Valerie Elizabeth Greene, C/o Mr JCM Grant, 1 Pullenvale Road, Pullenvale, Qld	275.00	"	06/12/00
Mrs Victoria Rae Greene, 38 West Street, Balgowlah, NSW	408.25	"	"
Mr Steven Gregg, 35 Prince Albert Street, Mosman, NSW	290.75	"	"
Mr Abner J. Greshler, C/o Sydney Rose, 123 Streatfield Road, Kenton Harrow Middlsex, UK	516.75	"	"
Griffin Nominees Pty Ltd, C/o KPMG Peat Marwick, PO Box H67, Australia Square, Sydney, NSW	329.72	"	03/07/00

Griffin Nominees Pty Ltd, C/o KPMG Peat Marwick, PO Box H67, Australia Square, Sydney, NSW	317.50	''	06/12/00
Mr Rex Willfred Griffin, 3 Ocean St, Lake Illawarra, NSW	266.08	''	03/07/00
Mr Rex Willfred Griffin, 3 Ocean St, Lake Illawarra, NSW	243.75	''	06/12/00
Mr John Joseph Griffith, Old Police Cottage, Dean Winchester S021 2LP United Kingdom	216.25	''	''
Mr John Joseph Griffith, Old Police Cottage, Dean Winchester S021 2LP United Kingdom	238.14	''	03/07/00
Miss Sylvia Grimm, 57 Corner Fielde-Wavertree Road, Streatham Hill, London SW2 4TJ United Kingdom	1,093.75	''	06/12/00
Mr Ian Henry Grist & Mrs Catherine Anne Grist, "Grist Management S/F A/c" C/- Frank De Stefano & Assoc. Level 4, 115 Myers Street, Geelong	150.37	''	03/07/00
Mr Ian Henry Grist & Mrs Catherine Anne Grist, "Grist Management S/F A/c" C/- Frank De Stefano & Assoc. Level 4, 115 Myers Street, Geelong	131.75	''	06/12/00
Gurawon Investments Pty Limited, "Chan Super Fund A/c", 63 Clanville Road, Roseville, NSW	129.00	''	''
Est Late Amanda Isabella Gurr, C/o J. & C. Gurr, 5 Davis Street, Speers Point, NSW	184.34	''	03/07/00
Mrs Deborah Judith Gwynne, 66 Riley Road, Dalkeith, WA	367.00	''	06/12/00
Mr Walter James Gye, 50 Darebin Street, Heidelberg	184.50	''	''
Mr Jeffery Arthur Gyles, 25 Oxford Street, Camberwell	290.50	''	''
Mr David Alexander Hall, 6/12 Brenbeal Street, Balwyn	780.00	''	03/07/00
Mr David Alexander Hall, 6/12 Brenbeal Street, Balwyn	750.00	''	06/12/00
Est Late Hilda M. Hall, C/o W. Hall, 6 Electra Street, Williamstown	572.65	''	03/07/00
Est Late Hilda M. Hall, C/o W. Hall, 6 Electra Street, Williamstown	551.75	''	06/12/00
Mr James Loddington Hall, 3 Ashmore Ave, Pymble, NSW	350.60	''	03/07/00
Mr Matt Bolton Hall, C/o PO Box 117, Gisborne, NZ	158.50	''	06/12/00
Mr David Macansh Halliday, 9/42 Little St, Forster, NSW	1,716.00	''	03/07/00
Mr David Macansh Halliday, 9/42 Little St, Forster, NSW	1,650.00	''	06/12/00
Halpron Pty Ltd, "Baker Super Fund A/c", PO Box 965, Bankstown, NSW	129.00	''	''
Mr Kevin Eric Hamlin, 38 Russell Street, Woonona, NSW	100.00	''	''
Mr Reginald Morris Hampton, 43 Nelson Street, Inglewood, WA	1,169.48	''	03/07/00
Mr Reginald Morris Hampton, 43 Nelson Street, Inglewood, WA	1,116.25	''	06/12/00
Mr Stuart Han, 40 Imperial Avenue, Bondi, NSW	104.00	''	03/07/00
Mr Stuart Han, 40 Imperial Avenue, Bondi, NSW	100.00	''	06/12/00
Mr Christopher Joseph Hancock, 22 Turner Street, New Lambton, NSW	125.00	''	''
Mrs Lynette Lillian Hansen, PO Box 21, Belgian Gardens, Qld	129.00	''	''
Mrs Patricia Zoe Hardy, 7 Curragundi Ave, Belrose, NSW	117.17	''	03/07/00
Mrs Joyce Elaine Hargreaves, 121 Ridgway Drive, Flagstaff Hill, SA	283.50	''	06/12/00
Mr David Charles Harkin, 35 Heather Grove, Kew	170.25	''	''
Mr David Charles Harkin, 35 Heather Grove, Kew	176.57	''	03/07/00
Mr Ernest Albert Harris, 41 Nepean Highway, Aspendale	490.00	''	06/12/00
Mr Frederick N. Harris, La Residence Du Casino, Rue Pasteur, Bloc B3, No 351 06500 Menton, France	121.91	''	03/07/00

2494 G 38 19 September 2002

Victoria Government Gazette

Mr Frederick N. Harris, La Residence Du Casino, Rue Pasteur, Bloc B3, No 351 06500 Menton, France	104.25	”	06/12/00
Mr Neville George Harris, 3 Chintabell Way, South Hedland, WA	312.75	”	03/07/00
Mrs Heather Jennifer Harrison, C/o A. J. Wilson, Chartered Accountant, PO Box 579, Spring Hill, Qld	469.71	”	”
Mrs Heather Jennifer Harrison, C/o A. J. Wilson, Chartered Accountant, PO Box 579, Spring Hill, Qld	452.50	”	06/12/00
Miss Lorna D. Harrison, 189 Rowntree St, Birchgrove, NSW	115.75	”	”
Mr Jean Pierre Harvey, 1/23 Christie St, Wollstonecraft, NSW	117.75	”	”
Mrs Wendy June Havelock Harvie, ‘Cluden’, 4 Archer Court, Brighton East	1,517.75	”	”
Mr Harry Hasiotis, 29 Willowbank Road, North Fitzroy	353.00	”	”
Mr Harry Hasiotis, 29 Willowbank Road, North Fitzroy Est Late David Cairns Hastie, C/o Chooi Shee Hoong & Hermes, 2nd Floor, No 140-2 Changkat Thamby Dollah Pudu, Kuala Lumpur	369.28	”	03/07/00
Mr Edward Gordon Hattersley & Mrs Julia Dianne Hattersley, “E. G. Hattersley S/Fund A/c”, 6/10 Wood St, Manly, NSW	743.08	”	”
Mr Edward Gordon Hattersley & Mrs Julia Dianne Hattersley, “E. G. Hattersley S/Fund A/c”, 6/10 Wood St, Manly, NSW	422.78	”	”
Mr John Hauser & Mr Oscar F. Boehringer & Mr Bruno Otto Cogliatti, C/o 44 Hertford Road, Digswell Welwyn, Hertfordshire AL6 0DB UK	396.00	”	06/12/00
Est Late Ian Murray Hay & Mr James Alexander R. Comfort, “A/c ATF Est Thomas Hay”, ‘Moravia’, Milton of Culloden, Inverness 1VI 2NT United Kingdom	105.00	”	”
Mr Anthony John Hayman, “Everglade Super Fund A/c”, PO Box 902, Neutral Bay, NSW	187.50	”	”
Mr Anthony John Hayman, “Everglade Super Fund A/c”, PO Box 902, Neutral Bay, NSW	115.18	”	03/07/00
Mrs Jessie Eva Hayman, C/o Royal Bank of Scotland Drummonds 49 Charing Cross Road, London SW1A 2DX UK	110.75	”	06/12/00
Mr Stuart James Hayward & Mrs Kathleen Miriam Hayward, PO Box 299, Wyong NSW	1,784.50	”	”
Mr Stuart James Hayward & Mrs Kathleen Miriam Hayward, PO Box 299, Wyong NSW	104.00	”	03/07/00
Est Late Valerie D. Hedger, C/o Mr P. Hodger, 89 Guildford Road, Surrey Hills	100.00	”	06/12/00
Est Late Valerie D. Hedger, C/o Mr P. Hodger, 89 Guildford Road, Surrey Hills	1,403.00	”	”
Heighton Pty Ltd, “Page Family A/c”, 14 Berry Street, East Melbourne	1,459.12	”	03/07/00
Helms Services Pty Ltd, Doncroft, 128 Blues Point Road, McMahons, Point NSW	100.00	”	06/12/00
Mr John Michael Herlihy, 15 Ferninand Street, Hunters Hill, NSW	766.50	”	”
Miss Karen Louise Hermann, 39 Calrossie Ave, Montmorency	535.75	”	”
Miss Karen Louise Hermann, 39 Calrossie Ave, Montmorency	131.92	”	03/07/00
Mr Francois X. G. D. Herwynen, Rue De Moriensart, 13 B1341 Ceroux-Mousty, Belgium	115.50	”	06/12/00
	125.30	”	03/07/00

Mr Francois X. G. D. Herwynen, Rue De Moriensart, 13 B1341 Ceroux-Mousty, Belgium	118.50	”	06/12/00
Mrs Raymonde A. Hiatt, Unit 34/297 Edgecliff Road, Woollahra NSW	153.00	”	”
Mrs Raymonde A. Hiatt, Unit 34/297 Edgecliff Road, Woollahra NSW	159.48	”	03/07/00
Mr William Paris Hiatt, 4 Shaw Avenue, Kingsford, NSW	187.00	”	06/12/00
Mr William Paris Hiatt, 4 Shaw Avenue, Kingsford, NSW	194.67	”	03/07/00
Mr Micheal John Hibbert, 9 Randall St, Agnes Banks, NSW	133.90	”	”
Mr Micheal John Hibbert, 9 Randall St, Agnes Banks, NSW	129.00	”	06/12/00
Mr Michael Justin Hibbins, 221 Burke Road, Glen Iris	133.90	”	03/07/00
Mr Michael Justin Hibbins, 221 Burke Road, Glen Iris	129.00	”	06/12/00
Mr David Mcalpine Hicks 28 Randell Street Parkdale	129.00	”	”
Mrs Gwendoline M. Hildebrandt, C/O Prophet Wealth Management, PO Box 7092, Riverside Centre, Brisbane, Qld	943.80	”	03/07/00
Mrs Gwendoline M. Hildebrandt, C/O Prophet Wealth Management, PO Box 7092, Riverside Centre, Brisbane, Qld	907.50	”	06/12/00
Mr Edward Hill & Mr James Michael Gerrard, 3 Sandy Lane, Aughton Near Ormskirk, Lancashire, UK	646.25	”	”
Mrs Virginia A. Hill, “Caroline Hill & Sam Hill A/c”, 11a Livingstone Avenue, Pymble NSW	112.00	”	”
Hing Cheong Pty Limited, C/o T. F. W. See & Lee, PO Box K251, Haymarket, NSW	286.00	”	03/07/00
Mr Benjamin Edward Hitchcock, Old Inverell Road, Armidale, NSW	101.50	”	06/12/00
H. L. Dawson & Son Pty Limited, PO Box 229, Paddington, NSW	667.00	”	”
H. L. Dawson & Son Pty Limited, PO Box 229, Paddington, NSW	693.68	”	03/07/00
Miss Irene Margaret Hobbs, 17 Rowan St, Mona Vale, NSW	180.37	”	”
Mr Harold Stanley Hodson, 185 Denison St, Hamilton, NSW	202.50	”	06/12/00
Ms Nicole D’Archy-D. Hoffmann, 55 Cedarleigh Road, Kenmore, Qld	107.00	”	”
Mrs Louise Hogan, The Grey House, New Road, Shiplake, Henly On Thames, Oxon RG-93IH United Kingdom	207.00	”	”
Mrs Patricia Hogan, 113 Buena Vista, Ave, Coorparoo, Qld	185.83	”	03/07/00
Mrs Patricia Hogan, 113 Buena Vista, Ave, Coorparoo, Qld	166.75	”	06/12/00
Ms Lesley Charlotte Hogarth, Prospect Cottage Glaisdale, Whitby YO21 2PL UK	215.25	”	”
Mr Hamish Tristram A. Holcombe, Merriba, Boggabilla, NSW	299.00	”	”
Hollinger Nominees Pty Ltd, C/o Bird Cameron, Box 973, Adelaide, SA	119.34	”	03/07/00
Mr John Hollingsworth & Mrs Diana Hollingsworth, Horne Hill, Rye Hill Lane, Broughton Hackett, Crowle Nr Worcester WR7 4BA United Kingdom	145.75	”	06/12/00
Mr Edward Paul Hollingworth & Mrs Lorraine Alma Donegan, 2/573 Toorak Road, Toorak	249.25	”	”
Mr Edward Paul Hollingworth & Mrs Lorraine Alma Donegan, 2/573 Toorak Road, Toorak	259.22	”	03/07/00
Mr Anthony David Holmes & Mr Peter Van Manser, 86 Collins Street, Hobart, Tas.	677.25	”	06/12/00

2496 G 38 19 September 2002

Victoria Government Gazette

Mr Robert James Holmes, PO Box 37, Tyabb	291.88	''	03/07/00
Mr Tony Holmwood, 1201/8 Spring St, Bondi Junction, NSW	371.02	''	''
Mr Victor Peter Holub, 22 Cecil Street, Williamstown	120.12	''	''
Mr Erwin Hor, 2 Torrington Road, Strathfield, NSW	122.46	''	''
Mr Erwin Hor, 2 Torrington Road, Strathfield, NSW	117.75	''	06/12/00
Dr Erwin Hor, 2 Torrington Road, Strathfield, NSW	520.00	''	03/07/00
Mrs Sarah Hordern, 6 Weld Street, Yarralumla, ACT	110.76	''	''
Mrs Sarah Hordern, 6 Weld Street, Yarralumla, ACT	106.50	''	06/12/00
Dr Magda Horvat, 6/316 Wattletree Road, East Malvern	2,024.75	''	06/12/00
Miss Asa Helina Howchin, C/o Mr J. B. Howchin, 57 Urunga Parade, Wollongong, NSW	104.50	''	06/12/00
Miss Asa Helina Howchin, C/o Mr J. B. Howchin, 57 Urunga Parade, Wollongong, NSW	108.68	''	03/07/00
Mr Santiago Huaypuna Campamento, 3 Edificio 1 Dpto 301 Tintaya Cusco, Peru	125.00	''	06/12/00
Mrs Susan Christine Hudson, 39B Blackacre Road, Theydon Bois Epping, Essex CM16 7LT UK	121.00	''	''
Mr Julian Hughes, 13 Muston Street, Mosman, NSW	135.32	''	03/07/00
Mr Timothy James Humphery, Lot 10, Range Road, Olinda	582.41	''	''
Mr Timothy James Humphery, Lot 10, Range Road, Olinda	560.50	''	06/12/00
Miss Bridget Clare Hutchinson, 35 Maning Avenue, Sandy Bay, Tas.	302.38	''	03/07/00
Miss Bridget Clare Hutchinson, 35 Maning Avenue, Sandy Bay, Tas.	290.75	''	06/12/00
Mrs Elizabeth Mary Hynes & Mr John Vincent Davis, C/o 509 Windsor Road, Baulkham Hills, NSW	161.20	''	03/07/00
Mr Mark Roland I'anson 26/4 Wilkins Street, Mawson, ACT	277.16	''	''
Mr Mark Roland I'anson 26/4 Wilkins Street, Mawson, ACT	266.50	''	06/12/00
Mrs Patricia Florence Ibbotson, C/o Cheryl Wright Ipac Securities, Locked Bag No 15, Grosvenor Place, Sydney, NSW	151.25	''	''
Mr Edward Ingoldsby, 5 Alford Grove, Sprowston, Norwich NR7 8XB UK	100.00	''	''
Miss Turi Kristine Innes, 15 Goodbury Avenue, Figtree, NSW	143.00	''	''
Miss Turi Kristine Innes, 15 Goodbury Avenue, Figtree, NSW	148.72	''	03/07/00
Inprint Superannuation Fund Pty Ltd, "Staff Super Fund A/c", PO Box 5, Virginia, Qld	171.60	''	''
Invia Custodian Pty Limited, "A. & J. Tso Eqf A/c", C/- S7711302M PSC, GPO Box 4595SS, Melbourne	1,250.00	''	06/12/00
Mr Graham Donald Irons, "Graham Irons Family A/c", PO Box 1747, North Sydney, NSW	260.00	''	03/07/00
Mrs Dorothea Genee Irving, 471 Riversdale Rd, Hawthorn	2,500.00	''	06/12/00
Mr Timothy Stuart Isaacson, 8/360 Beaconsfield Parade, St Kilda	211.00	''	''
Ms Amanda Helen Isdale, 7 Flaxton Terrace, Pannal, NZ	137.50	''	''
Ms Amanda Helen Isdale, 7 Flaxton Terrace, Pannal, NZ	143.00	''	03/07/00
Mrs Margaret Dewar Jack, Ardoch Holding, 15 West Cochno, Hardgate, Clydebank G81 6RT UK	306.75	''	06/12/00
Mrs Janet Florence Jackson & Mr Robert Owen Moore Jackson, "Adam Christopher Jackson A/c", PO Box 12, Yea	181.60	''	03/07/00
Mrs Janet Florence Jackson & Mr Robert Owen Moore Jackson, "Adam Christopher Jackson A/c", PO Box 12, Yea	175.75	''	06/12/00

Mrs Janet Florence Jackson & Mr Robert Owen Moore Jackson, "Catherine R. Jackson A/c", PO Box 12, Yea	181.60	"	03/07/00
Mrs Janet Florence Jackson & Mr Robert Owen Moore Jackson, "Catherine R. Jackson A/c", PO Box 12, Yea	175.75	"	06/12/00
Mrs Janet Florence Jackson & Mr Robert Owen Moore Jackson, "Laura Jane Jackson A/c", PO Box 12, Yea	181.60	"	03/07/00
Mrs Janet Florence Jackson & Mr Robert Owen Moore Jackson, "Laura Jane Jackson A/c", PO Box 12, Yea	175.75	"	06/12/00
Mrs Janet Florence Jackson & Mr Robert Owen Moore Jackson, "Rachel Clair Jackson A/c", PO Box 12, Yea	181.60	"	03/07/00
Mrs Janet Florence Jackson & Mr Robert Owen Moore Jackson, "Rachel Clair Jackson A/c", PO Box 12, Yea	175.75	"	06/12/00
Javel Pty Ltd, "Superannuation Fund A/c", PO Box 10, Coraki, NSW	339.00	"	"
Mr Ross Alfred Jenkins, 6/22 Furber Road, Centennial Park, NSW	106.00	"	"
Mr Ross Alfred Jenkins, 6/22 Furber Road, Centennial Park, NSW	110.24	"	03/07/00
Mr James Edward Jenkinson, PO Box 209, Sale	131.25	"	06/12/00
John C. Kennard Investments Pty Ltd, C/o T. R. Hazell, 7 Bickell Road, Mosman, NSW	472.79	"	03/07/00
John C. Kennard Investments Pty Ltd, C/o T. R. Hazell, 7 Bickell Road, Mosman, NSW	455.25	"	06/12/00
John R. Newcombe & Associates Pty Limited, Ashford Specialist Centre, Suite 12/2nd Floor, 57 Anzac Highway, Ashford, SA	176.80	"	03/07/00
John R. Newcombe & Associates Pty Limited, Ashford Specialist Centre, Suite 12/2nd Floor, 57 Anzac Highway, Ashford, SA	170.00	"	06/12/00
Miss Christine Ann Johnson, 17 Veronica Drive, Tallai, Qld	201.25	"	"
Miss Christine Ann Johnson, 17 Veronica Drive, Tallai, Qld	209.30	"	03/07/00
Mrs Lesley May Johnston, 51 Grey Street, East Melbourne	171.35	"	"
Mrs Dominique J. Johnstone, 27 Strickland Avenue, Lindfield, NSW	151.25	"	06/12/00
Mrs Dominique J. Johnstone, 27 Strickland Avenue, Lindfield, NSW	157.30	"	03/07/00
Mrs Gweneth Jones, 5 Entally Drive, Glen Waverley	1,052.52	"	03/07/00
Mrs Gweneth Jones, 5 Entally Drive, Glen Waverley	1,007.25	"	06/12/00
Mrs Valda Mary Jones, 146 Hotham Street, East St Kilda	151.08	"	03/07/00
Miss Hermione Caroline Joye, 66 Milson Road, Cremorne NSW	108.75	"	06/12/00
J. T. Investment Corporation Pty Limited, "Johnson Family Rtr Fund A/c", 402 Bourke Street, Surry Hills, NSW	150.00	"	06/12/00
J. T. Investment Corporation Pty Limited, "Johnson Family Rtr Fund A/c", 402 Bourke Street, Surry Hills, NSW	156.00	"	03/07/00

2498 G 38 19 September 2002

Victoria Government Gazette

Mr Maurice Jude & Mrs Satya Jude, "M & S Jude Super Fund A/c", 24 Circlewood Road, Algester, Qld	222.00	"	06/12/00
The Courts of Justice, "Jean Dundon A/c", Aras Ui Dhalaigh, Inns Quay, Dublin, Ireland	428.25	"	"
Mr Wai Fai Kan, PO Box 56, Pymble, NSW	286.00	"	03/07/00
Mr Wai Fai Kan, PO Box 56, Pymble, NSW	275.00	"	06/12/00
Mrs Wilhelmina Kaneen, 26 Cronkbourne Road, Douglas, Isle of Man	404.75	"	"
Mr Richard Keane 287 Greenhill Road Toorak Gardens SA	113.75	"	06/12/00
Mr Andrew Robert Kelly, 65 Spensley Street, Clifton Hill	308.10	"	03/07/00
Mr Andrew Robert Kelly, 65 Spensley Street, Clifton Hill	296.25	"	06/12/00
Mr Anthony Paul Kelly, C/o Sterling Software, Level 1, 171 Latrobe Street Melbourne	1,122.00	"	"
Mr Anthony Paul Kelly, C/o Sterling Software, Level 1, 171 Latrobe Street Melbourne	1,166.88	"	03/07/00
Mrs Gillian Kelly 73 Pacific Road Palm Beach NSW	176.75	"	06/12/00
Mrs Anne Marie Kemp, 388 Bay Street, Brighton	142.25	"	"
Mrs Anne Marie Kemp, 388 Bay Street, Brighton	146.97	"	03/07/00
Mr Graham Leslie Kemp, 40 Ithaca Road, Frankston	735.53	"	"
Mr Graham Leslie Kemp, 40 Ithaca Road, Frankston	707.00	"	06/12/00
Mr William Ross Kempster, 5/9-11 Bruce Road, Fairy Meadow, NSW	196.01	"	03/07/00
Mr William Ross Kempster, 5/9-11 Bruce Road, Fairy Meadow, NSW	175.50	"	06/12/00
Mr Francis William Kenealy & Mrs Nancy Coombs Kenealy, 10 Winmalee Road, Balwyn	157.30	"	03/07/00
Mr Francis William Kenealy & Mrs Nancy Coombs Kenealy, 10 Winmalee Road, Balwyn	151.25	"	06/12/00
Mr Tan Foo Keng, No 67 Lorong Lai Tet Loke 1, Kuala Lumpur, Malaysia	110.50	"	"
Mr Robert Bruce Kennedy, 5 Murex Way, South Hedland, WA	595.00	"	"
Ms Marilyn Elizabeth Kent, PO Box 22-199 Otahuhu, Auckland New Zealand	2,644.71	"	03/07/00
Miss Sabrina Petra Kerber, 17 Foote Street, Albert Park	734.75	"	06/12/00
Ms Kwai Fun Keung, 11A Broom Road, 3rd Floor, Happy Valley, Hong Kong	228.75	"	"
Ms Kwai Fun Keung, 11A Broom Road, 3rd Floor, Happy Valley, Hong Kong	237.90	"	03/07/00
Mr Edmond Keur, 265 The Boulevard, East Ivanhoe	105.75	"	06/12/00
Mr Edmond Keur, 265 The Boulevard, East Ivanhoe	114.18	"	03/07/00
Mr Johannes Khor, 855 Toorak Road, Hawthorn East	170.93	"	"
Mr Johannes Khor, 855 Toorak Road, Hawthorn East	164.25	"	06/12/00
Miss Jennifer M. King, 83 Victoria Park Rd, London E9 UK	147.00	"	"
Est Late John E. A. King, C/o Horton & Moss, 4/5 East Street, Ilkeston Derbyshire DE7 5JB UK	3,874.50	"	"
Mr Kerry Kingston, 8 Govett Crescent, Figtree, NSW	282.84	"	03/07/00
Mr Kerry Kingston, 8 Govett Crescent, Figtree, NSW	257.75	"	06/12/00
Mrs Patricia Marjorie Kinnear, 8 Rachel Crescent, Figtree, NSW	150.00	"	"
K. J. Oeding Pty Ltd, 6 Atherton Close, Rankin Park, NSW	332.00	"	"
K. J. Oeding Pty Ltd, 6 Atherton Close, Rankin Park, NSW	344.72	"	03/07/00

Mr Suwan Klinapai, BHPSteel (Thailand) Ltd, 2 Soi G 9 Pakornsongkrohrad Road, T. Maptaphut A. Muang Rayong, Thailand	125.00	''	06/12/00
Mr George William Knight, Turlinjah Via Moruya, NSW	185.76	''	03/07/00
Mr George William Knight, Turlinjah Via Moruya, NSW	179.50	''	06/12/00
Miss Samantha Therese Knight, 5/42 Campbell Street, Wollongong, NSW	170.75	''	''
Mr Dominic Norman Luke Knights, 102 Raglan Street, Port Melbourne	125.00	''	''
Mrs Alison Bertha Knudsen, Chesalon Nursing Home, 25 Trelawney Street, Eastwood, NSW	543.00	''	''
Mrs Rachael Anna Knudsen, 2-22-18 Minami-Cho Kichijoji Musashinoshi, Tokyo, Japan	101.25	''	03/07/00
Mr See Heong Koh, 681 Changi Road, Singapore	312.50	''	06/12/00
Mr Ilias Kostopoulos, 44 Westbourne Street, Prahran	125.00	''	''
Mr Andrew Anthony Kowalski, 16 Lilla Road, Pennant Hills, NSW	253.25	''	03/07/00
Kra Investment Company Limited, 41 Freame Way, Gillingham, Dorset SP8 4RA UK	110.00	''	06/12/00
Mrs Joan Bethsheba Krannin, C/o Public Trustee, GPO Box 2251, Brisbane, Qld	2,635.75	''	''
Mr Ian Marius Kreditor, 21 Woodlands Close, London NW11 9QR United Kingdom	348.25	''	''
Mrs Debra Kroon, PO Box 41951, Casuarina, NT	143.75	''	''
Mrs Debra Kroon, PO Box 41951, Casuarina, NT	149.50	''	03/07/00
Mr Joannes Kroonstuiver, 18 Saturn Street, Beckenham, WA	399.62	''	''
Mr Joannes Kroonstuiver, 18 Saturn Street, Beckenham, WA	384.25	''	06/12/00
Kydd Business Services Pty Ltd, "Provident Fund A/c", 10 Radnor Road, Galston, NSW	101.25	''	''
Mr Christopher John Kydd & Mr Andrew Charles Kydd, "Kydd Bus Serv Prov Fund A/c", 10 Radnor Road, Galston, NSW	184.75	''	''
Mrs Carolyn Anne Lake, 21 Hill Park Street, off Merton Lane, Highgate, London N6 6ND UK	123.75	''	''
Miss Margaret Rose Lambourne, Oakfield, Whitchurch Nr Reading, Berks, United Kingdom	573.50	''	''
Mr Robert Leslie Langer, PO Box 68, Burwood	562.50	''	''
Mrs Rose Lanyon, 168 Beach Road, Parkdale	136.24	''	03/07/00
Mrs Rose Lanyon, 168 Beach Road, Parkdale	131.00	''	06/12/00
Larost Pty Limited, C/- Ross Woods, Indooroopilly Pharmacy, 66 Station Rd, Indooroopilly, Qld	156.00	''	03/07/00
Larost Pty Limited, C/- Ross Woods, Indooroopilly Pharmacy, 66 Station Rd, Indooroopilly, Qld	150.00	''	06/12/00
Est Mr Edward Lau, 58 X4 Bank of China, Tower #1 Garden Road, Central Hong Kong	335.86	''	03/07/00
Est Mr Edward Lau, 58 X4 Bank of China, Tower #1 Garden Road, Central Hong Kong	308.75	''	06/12/00
Mrs Thelma Lawson, 7A Keldale Place, Milford, Auckland, NZ	324.74	''	03/07/00
Mrs Thelma Lawson, 7A Keldale Place, Milford, Auckland, NZ	312.25	''	06/12/00
Mr Charles Lay, 139 Mt Keira Road, Mt Keira, NSW	143.00	''	03/07/00
Mr Charles Lay, 139 Mt Keira Road, Mt Keira, NSW	137.50	''	06/12/00

2500 G 38 19 September 2002

Victoria Government Gazette

Miss Amanda Geraldine Leahy, 52/1 Tewkesbury Avenue, Darlinghurst, NSW	139.76	”	03/07/00
Miss Mary Louise Leben, C/o Miss V. Leben, Daprian Knight Australia, Level 1, 608 St Kilda Road, Melbourne	104.50	”	06/12/00
Miss Mary Louise Leben, C/o Miss V. Leben, Daprian Knight Australia, Level 1, 608 St Kilda Road, Melbourne	110.70	”	03/07/00
Mr Brett Lee, 8 Winter Avenue, Mount Warrigal, NSW	135.20	”	”
Madam Chin Poh Lee, 1 Holt Road, Singapore	1,133.88	”	”
Madam Chin Poh Lee, 1 Holt Road, Singapore	1,085.00	”	06/12/00
Mr Li Hwa Lee, 64 Jalan Lim Tee, Ee Boon Bak Garden, 31650 Ipoh Perak, Malaysia	105.13	”	03/07/00
Mr Michael Lee, Unit 143, 69 St Marks Road, Randwick, NSW	280.86	”	”
Mr Robert F. Lee, PO Box Hm 1551, Hamilton, HM FX Bermuda	250.25	”	06/12/00
Mr Soo Yee Lee, 4 Crisp Place, Karrinyup, WA	533.50	”	”
Ms Wooi Meng Lee, 87 Braeside Road, Greystanes, NSW	262.75	”	”
Ms Wooi Meng Lee, 87 Braeside Road, Greystanes, NSW	284.43	”	03/07/00
Mr Michael James Leeflang, 3/10 Overway Bridge Road, Gawler West, SA	129.00	”	06/12/00
Mr Ronald Bruce Legge, RMB 7280, Bairnsdale Lejoman Pty Ltd, 12 Floor, 55 Clarence Street, Sydney, NSW	148.25	”	”
Mrs Lorraine Francis Lennon, 20 Terry St, Balmain, NSW	693.50	”	”
Mrs Lorraine Francis Lennon, 20 Terry St, Balmain, NSW	881.75	”	”
Mrs Lorraine Francis Lennon, 20 Terry St, Balmain, NSW	932.48	”	03/07/00
Est Late Francis Leo, C/o Dang Bros, PO Box 416, Lae, Papua New Guinea	451.89	”	”
Est Late Francis Leo, C/o Dang Bros, PO Box 416, Lae, Papua New Guinea	428.50	”	06/12/00
Mr Garry Leong, “Tseming Nom Ret/Fund A/c”, 12th Floor, 55 Clarence Street, Sydney, NSW	368.25	”	”
Leslie W. K. Gan Pty Ltd, “Leslie W. K. Gan P/L S/F A/c”, 2 Palana Road, City Beach, WA	892.50	”	”
Leslie W. K. Gan Pty Ltd, “Leslie W. K. Gan P/L S/F A/c”, 2 Palana Road, City Beach, WA	478.10	”	03/07/00
Mr Colin Leung, 13th Floor, Block 3, Cavendish Heights, 33 Perkins Road, Jardine’s Lookout, Hong Kong	135.50	”	06/12/00
Mr Colin Leung, 13th Floor, Block 3, Cavendish Heights, 33 Perkins Road, Jardine’s Lookout, Hong Kong	140.92	”	03/07/00
Mr Kevin Leung, 13th Floor, Block 3, Cavandish Heights, 33 Perkins Road, Jardine’s Lookout, Hong Kong	154.18	”	”
Mr Kevin Leung, 13th Floor, Block 3, Cavandish Heights, 33 Perkins Road, Jardine’s Lookout, Hong Kong	148.25	”	06/12/00
Mrs Hendrika C. Lever, 227 Farmborough Road, Farmborough Heights, Unanderra, NSW	107.50	”	”
Mr Nicholas John Leverton, 123 Manor Park, Lewisham, London SE13 5RQ UK	105.75	”	”
Mr Bruce Ronald Lewis & Mrs Anne Lynette Lewis, “Lewis /Medical/ Sf No 1 A/c”, 33 Markwell Street, Hamilton, Qld	500.00	”	”

Mr Bruce Ronald Lewis & Mrs Anne Lynette Lewis, "Lewis /Medical/ Sf No 1 A/c", 33 Markwell Street, Hamilton, Qld	520.00	"	03/07/00
Ms Florence Lewis, 1/1 Domain Street, South Yarra	158.50	"	06/12/00
Ms Stephanie Helen Maitland-Lewis & Mr Richard Michael Fairbairn, "JB A/c", 1 Bell Yard, London WC2A 2JP United Kingdom	608.25	"	"
Mr Warren John Lewis, 61 Headlands Rd, Castle Cove, NSW	123.25	"	"
Mr Warren John Lewis, 61 Headlands Rd, Castle Cove, NSW	127.98	"	03/07/00
Mr Carl Long Hua Li, Room 1403/ D, Block 20, Guang An Men Bei Jie, Beijing, China	140.00	"	06/12/00
Mr Steven Ray Lieber, 5 Tomasina Court, Langwarrin	177.50	"	"
Mrs Ellen Lightfoot, C/o Anthony Lightfoot, 16 Balvicar Road, Blairgowrie, Johannesburg, South Africa	149.76	"	03/07/00
Mrs Ellen Lightfoot, C/o Anthony Lightfoot, 16 Balvicar Road, Blairgowrie, Johannesburg, South Africa	144.00	"	06/12/00
Miss Swee Hong Lim, 16/213 Blackburn Rd, East Doncaster	260.00	"	03/07/00
Miss Swee Hong Lim, 16/213 Blackburn Rd, East Doncaster	250.00	"	06/12/00
Ms Nicola Lipman & Mrs Tamara Lipman, 7A Fitzroy Street, Killara, NSW	330.75	"	"
Lizlaw Pty Limited, 1st Floor, 507 Victoria Avenue, Chatswood, NSW	543.00	"	"
Locksley Pty Ltd, "Locksley Super Fund A/c", PO Box 4054, East Burwood	562.50	"	"
Miss Fiona Margaret Logan, 6 Hennessy Place, Mandurah, WA	330.50	"	"
Est Late Siew Keng Loh, C/o Benjamin Yean & Co, No 5-1-10 1st Floor, Jalan 3/109f Taman Danau Desa, Kuala Lumpur, Malaysia	20,421.72	"	03/07/00
Mr Mavis Longhorn, 18 Thistleworth Close, Isleworth, Middlesex TW7 4QQ United Kingdom	231.25	"	06/12/00
Mr Thomas Neilson Lord, 10446 Greendale Drive, Tampa Fl 33626-5304 USA	108.75	"	"
Miss Margaret Ann G. Lowe, The Old Post Office, 1 Maes-Yr-Afon, Llancarfan Barry S Glamorgan CF6 9AG UK	1,773.50	"	"
Mr David Gregory Lowery, 27 Centenary Drive, Emerald, Qld	156.49	"	03/07/00
Mr David Gregory Lowery, 27 Centenary Drive, Emerald, Qld	141.75	"	06/12/00
Mr William John Lucas & Mrs Diana Kristine I. Lucas, 34 Kondoparinga Road, Meadows, SA	235.50	"	"
Mrs Kathleen Luke, Broadlands Gate, Broadlands Rd South, North Weirs Brockenhurst, Hampshire S042 7SX UK	236.00	"	"
Mr Colin Luxford, "Nicholas & Victoria A/c", 10B Beechworth Road, Pymble, NSW	283.50	"	"
Miss Rowena Lydon, 23 Repton Street, Pullenvale, Qld	351.33	"	03/07/00
M. & S. Custodians Pty Ltd, "Auld & Sons Pty Ltd S/F A/c", PO Box 321, Kyabram	211.25	"	06/12/00
M. & S. Custodians Pty Ltd, "Auld & Sons Pty Ltd S/F A/c", PO Box 321, Kyabram	230.59	"	03/07/00
Est Late Harry Grant Maby, 21 Pewley Way, Guildford, Surrey GU1 3PX UK	358.75	"	06/12/00

2502 G 38 19 September 2002

Victoria Government Gazette

Mrs Lily Stopford MacMermott, 61 Carr St, Waverton, NSW	1,128.66	''	03/07/00
Mrs Lily Stopford MacMermott, 61 Carr St, Waverton, NSW	1,085.25	''	06/12/00
Mr Barry Wayne Macdonald & Miss Margaret Alice MacDonald, 15 Summerhill Court, Wynn Vale, SA	156.00	''	03/07/00
Mr Craig MacGibbon, PO Box 452, Kaitaia, New Zealand	111.02	''	''
Mr Archibald MacIntyre, PO Box 194, Invercargill, Southland, New Zealand	116.24	''	''
Mr Archibald MacIntyre, PO Box 194, Invercargill, Southland, New Zealand	101.00	''	06/12/00
Mr Scott David MacIntyre, PO Box 1827, Mackay, Qld	852.50	''	''
Mr Scott David MacIntyre, PO Box 1827, Mackay, Qld	886.60	''	03/07/00
Mrs Helen Lucy MacKay, 22 Leigh Place, West Pennant Hills, NSW	106.47	''	''
Mrs Helen Lucy MacKay, 22 Leigh Place, West Pennant Hills, NSW	102.00	''	06/12/00
Est Late Glen Roy MacKereth, C/o Maeve O'Brien & Associates, PO Box 217, Kew	100.43	''	03/07/00
Mrs Julia Louise MacKie, 111A Tupwood Lane, Caterham, Surrey CR3 6DD UK	125.75	''	06/12/00
Mr Ian MacKinnon & Mrs Margaret MacKinnon, "J Mackinnon Super Fund A/c", 20 Finhaven Court, Kew	583.50	''	''
Mrs Barbara MacLeod, University South Pacific, PO Box 1168, Suva, Fiji	178.17	''	03/07/00
Mrs Barbara MacLeod, University South Pacific, PO Box 1168, Suva, Fiji	161.25	''	06/12/00
Miss Alexandra MacPherson, 32 Dalkeith Avenue, Wagga Wagga, NSW	169.00	''	06/12/00
Miss Alexandra MacPherson, 32 Dalkeith Avenue, Wagga Wagga, NSW	177.77	''	03/07/00
Mr Christopher E. MacPhillamy & Ms Caroline Moira Stevenson, "A/c M. M. Schoning", PO Box 3128, Manuka, ACT	660.00	''	06/12/00
Mrs Claire Phyllis Madigan, C/o Phillips Henderson Ward Limited, GPO Box 2419, Adelaide, SA	1,348.50	''	''
Mr Kalev Arno Maevali, 59 Marlo Street, Towradgi, NSW	177.50	''	''
Miss Jo Harvey Main, 9 Centre Court, Pakuranga, Auckland, NZ	1,529.46	''	03/07/00
Dr Joseph John Mann, 10 Chaddesley Avenue, St Kilda East	1,348.17	''	''
Mrs Maria Marek, 6 Liston Street, Bell Post Hill	390.00	''	06/12/00
Mrs Maria Marek, 6 Liston Street, Bell Post Hill	414.67	''	03/07/00
Mareldor Investment Corporation Pty Ltd, 70 Kingsway, Nedlands, WA	131.06	''	''
Mareldor Investment Corporation Pty Ltd, 70 Kingsway, Nedlands, WA	126.00	''	06/12/00
Est Late Gwendolene M. Mark, C/o Sternberg Thomas Clarke & Company, Provincial House 218-226 Bishopsgate, London EC2M 4QD UK	169.50	''	''
Mr Brian John Martin, 14 Balmer Crescent, Woonona, NSW	226.12	''	03/07/00
Mr Brian John Martin, 14 Balmer Crescent, Woonona, NSW	214.00	''	06/12/00
Mr Eric Robert Phillip Martin, Unit 4, "Lumeah", 26 Windsor Street, Nundah, Qld	284.00	''	''

Mr Eric Robert Phillip Martin, Unit 4, "Lumeah", 26 Windsor Street, Nundah, Qld	294.60	"	03/07/00
Ms Maree Frances Martini, 32 Rose Street, Alexandra	103.00	"	06/12/00
Mrs Joanna Helen Martzloff, C/o Mr J J Barkell Gordon & Johnstone, Level 3, 55 Market Street, Sydney, NSW	688.75	"	"
Mr Bela Matrai, "Elegant Tailoring Super A/c", PO Box 305, St Peters, NSW	126.00	"	"
Mr John Henry Matthews, 27 Church Street, North Hobart, Tas.	917.75	"	"
Mr John Henry Matthews, 27 Church Street, North Hobart, Tas.	954.23	"	03/07/00
Mr John Huish R. Matthews, "Oaklands", Cut Mill, Bosham, Chichester West, Sussex PO18 8PN UK	1,800.00	"	06/12/00
Mawabu Pty Limited, C/o Herkess & Partners, PO Box 639, Rockdale, NSW	255.50	"	"
Ms Yvonne Frances Mawson & Mr Andrew Keith Pearson & Mr Graham Laurie Lang, "Yvonne Mawson Family A/c", 17 Mill Road, Clive Hawkes Bay, New Zealand	117.00	"	03/07/00
Mrs Jennifer Marie Maxwell, 7 Penticost Street, Jubilee Pocket, Airlie Beach, Qld	157.75	"	06/12/00
Mrs Jennifer Marie Maxwell, 7 Penticost Street, Jubilee Pocket, Airlie Beach, Qld	172.98	"	03/07/00
Mrs Esther Irene Mayhew, 4 Maywood Rd, South Cranbourne	114.04	"	"
Mr Peter John Donald Mayne, C/o 7-11 Barry Drive, Turner, ACT	320.32	"	"
Mr Peter John Donald Mayne, C/o 7-11 Barry Drive, Turner, ACT	308.00	"	06/12/00
Mrs Mary Patricia McAllen, 15 Hamilton Parade, Hamilton, New Zealand	227.16	"	03/07/00
Mrs Mary Patricia McAllen, 15 Hamilton Parade, Hamilton, New Zealand	205.00	"	06/12/00
Miss Fiona Maree McCarthy, PO Box 123, Cunnamulla, Qld	289.25	"	"
Est Late Jean L McCarthy, C/o A I F Lucas & Co, PO Box 3193, Wheelers Hill	830.34	"	03/07/00
Est Late Jean L McCarthy, C/o A I F Lucas & Co, PO Box 3193, Wheelers Hill	787.25	"	06/12/00
Mr Peter Secord McCartney, 26 Mohilla Street, Mount Eliza	277.53	"	03/07/00
Mr Scott Cameron J. McDonald, PO Box 78, Barnawartha	191.50	"	06/12/00
Miss Louisa McDonnell, 36 Farley Court, Melbury Road, London W14 8LJ UK	310.75	"	"
Mrs Mareece Mary McElhinney, 99 Janet Street, Merewether NSW	248.50	"	"
Mrs Mareece Mary McElhinney, 99 Janet Street, Merewether NSW	273.61	"	03/07/00
Mrs Rosemary Ursula McElroy & Mr Michael Shane McElroy & Mr Arthur William Young, 54 Arney Road, Remuera, Auckland, New Zealand	173.00	"	06/12/00
Mr Kenneth Lachlan McFarlane, Lancarr House, 758 Drummond Street, North Carlton	284.75	"	"
Mr Thomas McGeachie, 2 Rata Road, Devonport, Auckland, New Zealand	174.75	"	"
Mr Thomas McGeachie, 2 Rata Road, Devonport, Auckland, New Zealand	181.74	"	03/07/00

2504 G 38 19 September 2002

Victoria Government Gazette

Mr Arthor Brooks McGowen, 96 Nimbus Way, Studlands Park, Newmarket, Suffolk CB8 7BW UK	117.75	''	06/12/00
Miss Ellen M. McInerney, Nazareth House, 218 Mill Street, Ballarat	187.75	''	''
Mr Denniston John McInnes, 72 Bolton Street, Eight Mile Plains, Qld	102.31	''	03/07/00
Mr Angus Campbell McKechnie, 15/449 St Kilda Road, Melbourne	1,475.50	''	06/12/00
Mr Angus Campbell McKechnie, 15/449 St Kilda Road, Melbourne	1,534.52	''	03/07/00
Mr Leonard Patrick McKewin & Mrs Kathryn Marguarite McKewin, 23 Turner Street, Eastern Heights, Qld	103.00	''	06/12/00
Mr Stuart Ross McLean Martindale, RMB 2115, Barnawartha	100.75	''	''
Mr Stuart Ross McLean Martindale, RMB 2115, Barnawartha	104.78	''	03/07/00
Est Late Margaret A. McMahan, C/o K. W. McMahan 39 Transit Way, Mullaloo, WA	305.76	''	''
Est Late Margaret A. McMahan, C/o K. W. McMahan 39 Transit Way, Mullaloo, WA	294.00	''	06/12/00
Miss Marina Doone McNamara, 9 Cabramatta Street, Bayswater, WA	135.55	''	03/07/00
Miss Mary Dympna McNamara, 97 Avenue Road, Mosman, NSW	366.75	''	06/12/00
Mrs Robina Marion McPhee, 39 Sadlier Street, Subiaco, WA	345.28	''	03/07/00
Mrs Robina Marion McPhee, 39 Sadlier Street, Subiaco, WA	332.00	''	06/12/00
McPherson Newspapers Pty Limited, PO Box 204, Shepparton	334.75	''	03/07/00
McPherson Newspapers Pty Limited, PO Box 204, Shepparton	322.00	''	06/12/00
Miss Deidre Mildred M. McQuade, The Ranges, MacPherson Street, Dandenong	186.89	''	03/07/00
Miss Deidre Mildred M. McQuade, The Ranges, MacPherson Street, Dandenong	180.50	''	06/12/00
McWhirter Investments Pty Ltd, PO Box 13, Berowra, NSW	102.00	''	''
Mrs Lois Geraldine Mead, 19 Park Avenue Bideford, Devon EX39 2QH UK	321.50	''	''
Mr James Meares & Mrs Sally Meares & Mr Sam Meares, 19 Roslyndale Avenue, Woollahra, NSW	251.17	''	03/07/00
Mr Michael Marius Meere & Mrs Julia Mary Meere, "Meere Family Super Fund A/c", 31 Edsall Street, Malvern	101.50	''	06/12/00
Mega Services Ltd, Block 81, Marine Parade, Central #01-642 Singapore	1,534.67	''	03/07/00
Mrs Margaret Ellen Mellon, 4 Beach St, Newcastle, NSW	100.25	''	06/12/00
Est Late Malcolm Menelaus & Mrs Margaret Menelaus, "James Menelaus Rush A/c", 5 Bayview Avenue, Hawthorn East	196.50	''	''
Mr Eric Robert Meppem, 12 Church Street, Yamba, NSW	118.56	''	03/07/00
Mr Eric Robert Meppem, 12 Church Street, Yamba, NSW	114.00	''	06/12/00
Mrs Anne Jennifer Merrington & Ms Christine Kay Massey & Mr Derek Ian Lamb, "Est Mary Hilda Mcgavin A/c", C/o R. Barnes, PO Box 34, 154 Birkenhead, Auckland, NZ	478.40	''	03/07/00
Meteso Pty Limited, PO Box 5220, Chatswood West, NSW	263.30	''	''
Mrs Noleen Lauraine Meteyard, "Milray Station", Pentland, Qld	112.75	''	06/12/00

Miss Naomi Marion Meth, 68 Chelmsford Avenue, Lindfield, NSW	254.75	''	''
Mrs Ruth Marie Noelle Meyer, C/o M. Johnson & Co, 1st Floor, 710 Burke Road, Camberwell	124.00	''	''
Dr Maxwell Michael, 9 Wallis Avenue, Ivanhoe East	343.20	''	03/07/00
Dr Maxwell Michael, 9 Wallis Avenue, Ivanhoe East	330.00	''	06/12/00
Mr Karel Robert G. Michielsen, C/o Post Office Littlehampton, SA	104.00	''	''
Mr Andrew James Mierendorff, 5 Pecten Way, South Hedland, WA	162.00	''	06/12/00
Mrs Menka Mignod, 58 Rutherford Road, Rosanna East	152.75	''	''
Mr Barry Vaughan Milborrow, School of Biochemistry, University of New South Wales, Sydney NSW	205.00	''	''
Mr Gordon Lambert Miles & Mrs Amy Loretto Miles, "JE Miles Family Invest A/c" 9 Stewart St, Clayfield, Qld	360.00	''	''
Miss Katharine M. Millear, "Yooranalee". Willaura	223.42	''	03/07/00
Miss Katharine M. Millear, "Yooranalee". Willaura	215.75	''	06/12/00
Millenium Group Pty Limited, "Superannuation Fund A/c", 214 Crown Street, East Sydney, NSW	125.00	''	''
Millenium Group Pty Limited, "Superannuation Fund A/c", 214 Crown Street, East Sydney, NSW	130.00	''	03/07/00
Est Late William Millwood, C/o Messrs Eric Butler Solicitors, PO Box 912, Charlestown, NSW	320.84	''	''
Est Late Wong Chee Min, C/o Messrs Lo & Lo, 11th Floor Swire House, Chater Road, Hong Kong	108.16	''	''
Est Late Wong Chee Min, C/o Messrs Lo & Lo, 11th Floor Swire House, Chater Road, Hong Kong	104.00	''	06/12/00
Miss Kathleen Ann Mitchell, 33 Lovell Road, Eastwood, NSW	125.00	''	''
Ms Lorraine Mitchelmore, 39 Prestwick Circle, Se Calgary AB T2Z 314 Canada	125.00	''	''
Miss Samantha Leigh Moffat, 11 Rednal Street, Mona Vale, NSW	136.25	''	''
Mr Michael Anthony Francis Mollard, 7/9 Barnsbury Road, South Yarra	181.14	''	03/07/00
Mr Michael Anthony Francis Mollard, 7/9 Barnsbury Road, South Yarra	168.50	''	06/12/00
Ms Valerie Angela L. Molloy & Ms Susan Garforth, "Fast-Track Super A/c", PO Box 415, Oaklands Park, SA	129.25	''	''
Mr Peter Henry Molony, 59 Berkeley Avenue, Heidelberg	218.14	''	03/07/00
Mr Peter Henry Molony, 59 Berkeley Avenue, Heidelberg	209.75	''	06/12/00
Monaco View Pty Limited, "Livadaras Super Fund A/c", 51 Thanet Street, Malvern	102.22	''	03/07/00
Mr David Scott Moncur & Mr Grant Arthur McSkimming, PO Box 21742, Henderson Auckland New Zealand	542.25	''	06/12/00
Mr Robin James Moon, PO Box 913, Armidale, NSW	144.81	''	03/07/00
Mr Christopher William S. Moor, 279/2 Moo 2 So 1 Tongpoon-U-Tid KM33 Phaholyothin Rd, Thanyaburi Pathumthani, Thailand	107.12	''	''
Mrs Judy Jane Moore, Kyleneahoura House, Ballyhooly, Mallow Co, Cork, Eire	392.25	''	06/12/00

2506 G 38 19 September 2002

Victoria Government Gazette

Mrs Judy Jane Moore, Kyleneahoura House, Ballyhooly, Mallow Co, Cork, Eire	407.94	”	03/07/00
Mr Lester Anaru Moore, 233 Lonely Track Road, Albany, Auckland, NZ	696.39	”	”
Miss Edwina A. Drummond-Moray, 1 Towers Rd, Toorak	145.07	”	”
Mr Jonathan M. V. Hughes-Morgan, 26 Palmerston Road, East Sheen, London SW14 7PZ UK	915.00	”	06/12/00
Mr Chikasi Moriguchi, 3-6-232 Miyojochi Uji, Kyoto, Japan	370.25	”	”
Mr David Francis Moroney, 97 Emerald Hill Rd, Singapore	196.82	”	03/07/00
Mr Robin M. Morphett, PO Box 9, Euroa	107.50	”	06/12/00
Mr Rodney Norman Morphett, 66 Warraba Road, Narrabeen, NSW	335.58	”	03/07/00
Mrs Lucy Frances Morrison, 54/20 Grant St, East Brighton	377.50	”	06/12/00
Mrs Roa Morrissey, 63A Ranolf Street, Rotorua, NZ	259.00	”	”
Mrs Roa Morrissey, 63A Ranolf Street, Rotorua, NZ	269.36	”	03/07/00
Mosshaven Investments Pty Ltd, C/o Mr J. C. Callum, 36 The Crescent, Ashmore, Qld	137.50	”	06/12/00
Mosshaven Investments Pty Ltd, C/o Mr J. C. Callum, 36 The Crescent, Ashmore, Qld	143.00	”	03/07/00
Mr Charles Richard Mouyat, 1007 Old Northern Road, Dural, NSW	625.00	”	06/12/00
Mr Ian Phillip Moyle, Kufpec Indonesia Ltd, PO Box 4292/Jkt, Jakarta, Indonesia	286.00	”	03/07/00
Mr Ian Phillip Moyle, Kufpec Indonesia Ltd, PO Box 4292/Jkt, Jakarta, Indonesia	275.00	”	06/12/00
Mulway Pty Limited, “A/c S F”, 66 John Street, Petersham, NSW	159.50	”	”
Mr Geoffrey Allan Munn, Box 347, Redcliffs	213.50	”	”
Mr Adam B. Munro, GPO Box 5344, Sydney, NSW	401.82	”	03/07/00
Mr Adam B. Munro, GPO Box 5344, Sydney, NSW	380.00	”	06/12/00
Mr Peter David Murphy, C/o White McIntyre & Co, PO Box 1155, Chatswood, NSW	496.74	”	03/07/00
Mr Peter David Murphy, C/o White McIntyre & Co, PO Box 1155, Chatswood, NSW	468.50	”	06/12/00
Mr Allan George Myler, 554 Greens Road, Lower Portland, NSW	197.50	”	”
Mr Nana Nabave & Mr Lagara Nabave & Mr Erero Sasive, PO Box 228, Popondetta Oro Province, Papua New Guinea	122.46	”	03/07/00
Mr Nana Nabave & Mr Lagara Nabave & Mr Erero Sasive, PO Box 228, Popondetta Oro Province, Papua New Guinea	117.75	”	06/12/00
Mrs Siew Gaik Nair, 9 Jalan Taman Seputeh, 3 Taman Seputeh, Kuala Lumpur, Malaysia	141.75	”	”
Est Late Frederick Byro Nair, C/o Graeme Frederick Nair, 5/40 Hogarth Way, Bateman, WA	123.50	”	”
Mr Masanobu Nakagawa, 4-3-17 Johsui-Honcho Kodaira-Shi, Tokyo, Japan	477.36	”	03/07/00
Mr Masanobu Nakagawa, 4-3-17 Johsui-Honcho Kodaira-Shi, Tokyo, Japan	459.00	”	06/12/00
Est Late Peter Nash, C/o Greig Bourke, PO Box 5121, Auckland, New Zealand	117.75	”	”
N. B. Powell (Nominee) Pty Ltd, “Maggie Lam Super Fund A/c”, Level 12, 55 Clarence Street, Sydney, NSW	125.00	”	”

<i>Victoria Government Gazette</i>	<i>G 38</i>	<i>19 September 2002</i>	<i>2507</i>
Mrs Cindy Maria Neilson, 38 Goode Street, Dubbo, NSW	102.16	”	03/07/00
Mrs Hilary Louise Neilson, PO Box 8382, Havelock North, Hawkes Bay, New Zealand	281.50	”	06/12/00
Mr Peter Bryan Neilson, 11 Eleanor Drive, Silvan	130.75	”	”
Mr Peter James Neville, 148 Stock Road, Attadale, WA	742.50	”	”
Mrs Catherine Newing & Ms Jane Newing, C/o Mrs M. Newing, 1/32 Clendon Road, Toorak	120.65	”	03/07/00
Mrs Catherine Newing & Ms Jane Newing, C/o Mrs M. Newing, 1/32 Clendon Road, Toorak	101.75	”	06/12/00
Mr Michael Frederick Newman, 3 Borrowdale Street, Red Hill, ACT	1,580.24	”	03/07/00
Miss Eve Chuen Ng, 4 Esperance Road, Mount Waverley	230.50	”	06/12/00
Mrs Seok Hean Ng, 4 Esperance Road, Mount Waverley	1,469.25	”	”
Mrs Joan Elizabeth Nicholls, 125 Curtain St, North Carlton	183.50	”	”
Mrs Meryl A. Nicol, 7 Rostrevor Parade, Mont Albert	140.50	”	”
Mr Robert James Nivison, Unit 35, 2 Grafton Street, Chippendale, NSW	125.00	”	”
Noblelink Administration Services Pty Ltd, “Wyo P/L Kerr Super A/c”, 90 Newmans Rd, Templestowe	157.30	”	03/07/00
Noblelink Administration Services Pty Ltd, “Wyo P/L Kerr Super A/c”, 90 Newmans Rd, Templestowe	151.25	”	06/12/00
Mr Tamagan Noga, Ok Tedi Mining Limited, Mining Division, Private Mail Bag, Port Moresby Ncd, Papua New Guinea	125.00	”	”
Mr Thomas Michael Noonan, 47 Elliott Avenue, Balwyn	200.00	”	”
Mr Michael David Norbury, 107 Park Road, Donvale	303.40	”	03/07/00
Mr Ian Percy Northey, Limpsfield, 55 Tregolls Road, Truro, Cornwall, United Kingdom	516.50	”	06/12/00
Notvero Pty Ltd, “Brian Overton Ret Fund A/c”, 49 Inverness Way, North Balwyn	107.75	”	”
Notvero Pty Ltd, “Brian Overton Ret Fund A/c”, 49 Inverness Way, North Balwyn	112.06	”	03/07/00
Mr Michael John Nunn, 15 Elliott Street, Campbell, ACT	100.00	”	06/12/00
Mr Ikenna Nwokolo, PO Box 1749, Boroko, PNG	112.00	”	”
Nyco Pty Limited, “N. A. Curtis Super Fund A/c”, C/o Sino Mining International Ltd, 8th Floor/10 Bond Street, Sydney, NSW	500.00	”	”
Nyco Pty Limited, “N. A. Curtis Super Fund A/c”, C/o Sino Mining International Ltd, 8th Floor/10 Bond Street, Sydney, NSW	520.00	”	03/07/00
Mr Vanco Obednikovski, 54 Kembla St, Port Kembla, NSW	181.50	”	06/12/00
Mr John B. O’Brien, C/o Westpac Banking Co, La Trobe University, Bundoora	113.17	”	03/07/00
Mr John B. O’Brien, C/o Westpac Banking Co, La Trobe University, Bundoora	109.50	”	06/12/00
Mrs Lynelle Anne O’Connor & Mr Michael Patrick O’Connor, “MP & LA O’Connor Super A/c”, 23 Arden Street, Clovelly, NSW	133.90	”	03/07/00
Mrs Lynelle Anne O’Connor & Mr Michael Patrick O’Connor, “MP & LA O’Connor Super A/c”, 23 Arden Street, Clovelly, NSW	129.00	”	06/12/00

2508 G 38 19 September 2002

Victoria Government Gazette

Mrs Maria O'Donnell & Mr Paul Maurice O'Donnell, 17/46 Morton Street, Wollstonecraft, NSW	202.02	''	03/07/00
Mrs Maria O'Donnell & Mr Paul Maurice O'Donnell, 17/46 Morton Street, Wollstonecraft, NSW	194.25	''	06/12/00
Mr Philip Barry O'Keefe, 9 David St, Clifton Gardens, NSW	126.85	''	03/07/00
Miss Vanessa Louise O'Keefe, 9 David Street, Clifton Gardens, NSW	123.25	''	06/12/00
Miss Vanessa Louise O'Keefe, 9 David Street, Clifton Gardens, NSW	142.25	''	03/07/00
Est Mr Daniel Francis O'Keeffe, C/-Mrs Mary Josephine O'Keeffe, 31 St Helena Parade, Eastlakes, NSW	187.50	''	06/12/00
Ms Sara-Kate Oldfield, 105 Princes Street, Carlton	142.00	''	''
Mr Colman O'Lughlen, PO Box 9290, Dubai, United Arab Emirates	767.51	''	03/07/00
Mrs Claudia Mary O'Malley, 94 Essex St, Wembley, WA	427.44	''	''
Mr Bernard O'Neil, 10 Square De La Tour Maubourg, Paris, France	398.25	''	06/12/00
Mr Bernard O'Neil, 10 Square De La Tour Maubourg, Paris, France	414.18	''	03/07/00
Mr Paul Gregory O'Neill, 807/57 Upper Pitt Street, Kirribill, NSW	113.00	''	06/12/00
Est Late Vi Chan Ong, C/o Gordon Cheng, 7th Floor, Pearl Assurance House, 32 Grenfell Street, Adelaide, SA	417.30	''	03/07/00
Father Kevin Joseph O'Reilly, 2 Havelock Street, Mulwala, NSW	401.25	''	06/12/00
Father Kevin Joseph O'Reilly, 2 Havelock Street, Mulwala, NSW	174.98	''	03/07/00
Father Kevin Joseph O'Reilly, 2 Havelock Street, Mulwala, NSW	168.25	''	06/12/00
Est Late Ronald Orny, C/o M. L. Konc, 34 Rue De La Plaine, Sainte Geven 'E' Ve Des Bois, France	239.75	''	06/12/00
Est Late Ronald Orny, C/o M. L. Konc, 34 Rue De La Plaine, Sainte Geven 'E' Ve Des Bois, France	249.34	''	03/07/00
Mr Steven Robert Osborn, 15 Robertson Rd, Valentine, NSW	367.25	''	06/12/00
Mrs Elizabeth J. L. O'Sullivan, "Yaxley Family A/c", 4 Bowman Street, Shenton Park, WA	107.00	''	''
Ms Barbara Joan Overend, C/o E. Newcomen, PO Box 14, Ensay	255.76	''	03/07/00
P. A. McGuiggan Pty Limited, "Superannuation Fund A/c", 37 Coldstream Street, South Coogee, NSW	129.75	''	06/12/00
Miss Betty Page, C/o R. J. Thomas, 216 Dohles Rocks Road, Murrumba Downs, Qld	200.50	''	''
Miss Betty Page, C/o R. J. Thomas, 216 Dohles Rocks Road, Murrumba Downs, Qld	207.55	''	03/07/00
Mr John Russell Palfreyman, 54 Elizabeth Street, Malvern	152.24	''	''
Mr Silvio Panetta, 74 Cowper Street, Port Kembla, NSW	129.89	''	''
Mr John Ellis Panton & Mrs Kaye Panton, "Pilsta Executive S/F 1 A/c"			
C/o Mr John Panton, 98 Maude Street, Shepparton	185.90	''	''
Mr John Ellis Panton & Mrs Kaye Panton, "Pilsta Executive S/F 1 A/c"			
C/o Mr John Panton, 98 Maude Street, Shepparton	178.75	''	06/12/00
Mr Richard T. Rodda-Pascall, C/o Philip Pascall, 52 Irvine Street, Peppermint Grove, WA	436.93	''	03/07/00

Mr Richard T. Rodda-Pascall, C/o Philip Pascall, 52 Irvine Street, Peppermint Grove, WA	420.00	''	06/12/00
Ms Catherine Veronica Patchell, 1051 Malvern Road, Toorak	229.32	''	03/07/00
Ms Catherine Veronica Patchell, 1051 Malvern Road, Toorak	220.50	''	06/12/00
Mrs Faye Lorraine Paton, 16 Frazer Street, Collaroy, NSW	223.48	''	03/07/00
Mrs Faye Lorraine Paton, 16 Frazer Street, Collaroy, NSW	211.00	''	06/12/00
Miss Wendy Elisabeth Payne, East Bursea Farm, Holme-On-Spalding Moor, York YO4 4DB United Kingdom	385.00	''	''
Mrs Kerrilyn Anne Peake, 288 Sheffield Road, Montrose	138.25	''	''
Mrs Joan K. Penfold, 20 Amesbury Crescent, Hove, Sussex BN3 5RD UK	887.50	''	''
Mr John W. Pennefather, 3 Gladys Avenue, Frenchs Forest, NSW	878.80	''	03/07/00
Mr Nicholas John Penny, 41 St James Road, Bondi Junction, NSW	100.40	''	''
Mr Nicholas John Penny, "T A/c", PO Box R905, Royal Exchange, Sydney, NSW	113.80	''	''
Mr Nicholas John Penny, "T A/c", PO Box R905, Royal Exchange, Sydney, NSW	110.50	''	06/12/00
Mr Walter Francis Perkins, 12 Moore Street, Elwood Perpetual Trustee Company Limited, "PIW2 A/c", L19, 1 Castlereagh Street, Sydney, NSW	149.00	''	''
Mr Andrew Michael Person, 25 Cricklewood Avenue, Frankston	722.28	''	03/07/00
Mr Richard John Peters, 35 Farrington Road, Leeming, WA	130.00	''	''
Mr Peter Pettit & Miss May Morwen Pettit, "GMD A/c", Gregory Rowcliffe & Milners, 1 Bedford Row, London WC1R 4BZ United Kingdom	650.00	''	''
Mrs Dorothy Beatrice Phillips, C/- Axedale Post Office, Axedale	446.25	''	06/12/00
Mrs Marion Agnes Phillips, Mt Playfair, Tambo, Qld	128.50	''	''
Mrs Nancy Claire Phillips, 1221 Burke Road, Kew	171.20	''	03/07/00
Mr William B. Phillips & Est Late Donald E. Rollason, 27/17 Heydon Street, Mosman, NSW	106.75	''	06/12/00
Mr William B. Phillips & Est Late Donald E. Rollason, 27/17 Heydon Street, Mosman, NSW	374.50	''	''
Mr Jozef Piotrowski, GPO Box 4765, Sydney, NSW	388.82	''	03/07/00
Piriba Pty Limited, GPO Box 2969, Sydney, NSW	597.10	''	''
Piriba Pty Limited, GPO Box 2969, Sydney, NSW	122.72	''	''
P. J. Farrell Pty Limited, "Superannuation Fund A/c", 6 Hall Street, Newcastle West, NSW	118.00	''	06/12/00
Mr George Pleski, 5 Jalna Avenue, Figtree, NSW	150.00	''	06/12/00
Mr Harold Charles F. Plumley, 6 Prangley Avenue, Mangere Central, Auckland, NZ	156.75	''	''
Mr Harold Charles F. Plumley, 6 Prangley Avenue, Mangere Central, Auckland, NZ	257.00	''	''
Mr Murray Barton Podbury, PO Box 918, Frankston	269.92	''	03/07/00
Mr Murray Barton Podbury, PO Box 918, Frankston	231.46	''	''
Polden Pty Ltd, "Hansford Super Fund A/c", 20 Berrima Road, Donvale	222.50	''	06/12/00
Polden Pty Ltd, "Hansford Super Fund A/c", 20 Berrima Road, Donvale	164.84	''	03/07/00
	158.50	''	06/12/00

2510 G 38 19 September 2002

Victoria Government Gazette

Mr Michael Hamilton Pope & Mr Michael Ian Jackson, C/o Stevens Drake & Pope, 56–58 Church Road, Burgess Hill, West Sussex RH15 9AS United Kingdom	769.00	”	”
Mr Clifford John Powell, 49 Queens Road, New Lambton, NSW	151.00	”	”
Miss Janet Lesley Powell, 7 McGregor Road, R D 2 Papakura, New Zealand	108.25	”	”
Miss Janet Lesley Powell, 7 McGregor Road, R D 2 Papakura, New Zealand	112.58	”	03/07/00
Mr Peter Powell, 2 Earlswood Gardens, Clayhall, Ilford, Essex IG5 0DF United Kingdom	1,162.25	”	06/12/00
Mrs Marie Laura Power, 20 Ronaki Road, Mission Bay, Auckland, New Zealand	145.34	”	03/07/00
Mrs Marie Laura Power, 20 Ronaki Road, Mission Bay, Auckland, New Zealand	139.75	”	06/12/00
Mr Alan David Poyner, 67 King Street, Coonabarabran, NSW	312.50	”	”
P. R. Trevillian Pty Ltd, “Super Fund A/c”, 29 Blaxland Road, Cardiff, NSW	351.50	”	”
Mr Andrew Pratten, 266 Albert Road, South Melbourne	141.75	”	”
Est Late Rosalind H. P. Price, 32 Hampstead Grove, London NW3 6SR United Kingdom	360.75	”	”
Mr Christopher Cyril K. Priebe, 43 Bloomfield Terrace, London SW1W 8PQ United Kingdom	130.00	”	”
Mr Barry McDonald Prize, Level 10, ANZ Bank, 20 Martin Place, Sydney, NSW	486.45	”	03/07/00
Mr Barry McDonald Prize, Level 10, ANZ Bank, 20 Martin Place, Sydney, NSW	468.50	”	06/12/00
Proceres Pty Ltd, Level 2, 25 Dorcas Street, South Melbourne	155.74	”	03/07/00
Dr Michael David Proud & Mrs Luveni Naomi Proud, “D Proud Super Fund A/c”, 20 Main Street, Sheffield, Tas.	247.50	”	06/12/00
The Public Trustee, “Amanda L. Struthers A/c”, PO Box 5024, Wellington, New Zealand	519.22	”	03/07/00
The Public Trustee, “M4302 A/c”, Stewart House, Kingsway, London WC2B 6JX United Kingdom	726.00	”	06/12/00
Mr Desmond Francis Puertollano, PO Box 865, Derby, WA	113.75	”	”
Mr Michael John Purdie, 5/88 Forrest Street, Cottesloe, WA	137.50	”	”
Mr Malcolm John Pym, 6/58 Wattletree Road, Armadale	156.00	”	03/07/00
Mr Peter Thomas Quinn, 34 Lawson St, Paddington, NSW	109.00	”	06/12/00
Mrs Patricia Mary Quirk, Lighthouse Cottage, No 1 Barrenjoey Headland, C/o PO Palm Beach, NSW	137.50	”	”
Mrs Patricia Mary Quirk, Lighthouse Cottage, No 1 Barrenjoey Headland, C/o PO Palm Beach, NSW	143.00	”	03/07/00
Miss Rosemary Anne Quoye, C/o Mrs Rosemary A Allsopp, 30 Huntleys Road, Huntleys Point, NSW	132.25	”	06/12/00
Mrs Penelope Carolyn Raggatt, 42 Copse Hill, Wimbledon, London SW20 OHQ UK	346.50	”	”
Mrs Jacqueline Ann Ralph & Mr Phillip Gordon Simpson, “David Wayne Simpson A/c”, 1597 Nimbin Road, Goolmangar Via Lismore, NSW	167.75	”	”
Rapvan Pty Ltd, C/o Mr Brian Walsh, Lot 98, South Boundary Road, East Pearce Dale	134.94	”	03/07/00

Rapvan Pty Ltd, C/o Mr Brian Walsh, Lot 98, South Boundary Road, East Pearcedale Mr Douglas Frederick Rathbone, 3/112 Crystal Palace Park Road, Sydenham, London SE26 United Kingdom	129.75	”	06/12/00
Mr Kenneth Frank Reed, 165 Wilton Road, Wilton, NSW	395.25	”	”
Mr Kenneth Frank Reed, 165 Wilton Road, Wilton, NSW	130.00	”	03/07/00
Est Late Dorothea L. Rees, C/o Warren Rees, RMB 2110, Cowes	125.00	”	06/12/00
Est Late Dorothea L. Rees, C/o Warren Rees, RMB 2110, Cowes	129.48	”	03/07/00
Ms Jean Alice Reeves, C/o Mr R. H. Reeves, 13 Corniche Road, Church Point, NSW	124.50	”	06/12/00
Ms Jean Alice Reeves, C/o Mr R. H. Reeves, 13 Corniche Road, Church Point, NSW	246.25	”	”
Refgo Pty Ltd, “Mentiplay Super Fund A/c”	265.37	”	03/07/00
Est Late Andrew L. Reid, C/o E. L. Grant & I. L. Reid, 45 Greville Street, Prahran	250.00	”	06/12/00
Est Late Andrew L. Reid, C/o E. L. Grant & I. L. Reid, 45 Greville Street, Prahran	110.75	”	”
Mr Sean Reivers, 94/108 Greville Street, Prahran	115.18	”	03/07/00
Mr Sean Reivers, 94/108 Greville Street, Prahran	130.00	”	”
Mrs Julia Helen M. Renouf, 37 Coleraine Road, Blackheath, London SE3 7PF UK	125.00	”	06/12/00
Mr Adrian James Rex, 11 Hendrick Street, Cardiff, NSW	728.00	”	”
Mr Adrian James Rex, 11 Hendrick Street, Cardiff, NSW	700.00	”	03/07/00
Est Late Beatrice Rex, C/o David R. Rex, PO Box 380, Katoomba, NSW	150.00	”	06/12/00
Est Late Beatrice Rex, C/o David R. Rex, PO Box 380, Katoomba, NSW	156.00	”	”
Ms Janice Annette Reynolds, 7 Middle Street, Caves Beach, NSW	156.00	”	03/07/00
Ms Janice Annette Reynolds, 7 Middle Street, Caves Beach, NSW	151.25	”	06/12/00
Ms Jane Rhodes, 13 Hesperia Avenue, City Beach, WA	157.30	”	03/07/00
Mrs Dorina Carmela Ricci, 17 Carter Street, Thorngate, SA	114.75	”	06/12/00
Mr Andrew William Richards, 24 Owen Stanley Avenue, Beacon Hill, NSW	143.50	”	”
Mr Andrew William Richards, 24 Owen Stanley Avenue, Beacon Hill, NSW	128.42	”	03/07/00
Mr Simon Nicholas Richmond, Locked Bag 7, Beaconsfield, NSW	118.25	”	06/12/00
Mrs Heather May Ridout, 3 Little Street, Mosman, NSW	104.25	”	”
Mr Richard M Riseley, 43 Leeds Road, Mt Waverley	137.50	”	”
Mr David Ritchie, PO Box 94, Annandale, NSW	200.25	”	”
Mr David Ritchie, PO Box 94, Annandale, NSW	2,027.00	”	06/12/00
RJ Craig Nominees Pty Ltd, 4/13 Hewitt Avenue, Rose Park, SA	2,108.08	”	03/07/00
Mr Leonard Robbins & Ms Adrienne Robbins, C/- JT Portfolio Admin, GPO Box 4817TT, Melbourne	1,963.25	”	06/12/00
Mr Richard M. Roberts, 52 Ellalong Road, Cremorne, NSW	261.75	”	”
Mr Richard M. Roberts, 52 Ellalong Road, Cremorne, NSW	146.90	”	03/07/00
Mr David Leslie Robertson, 25 Parsons Ave, Glen Waverley	141.25	”	06/12/00
	248.48	”	03/07/00

2512 G 38 19 September 2002

Victoria Government Gazette

Mr David Leslie Robertson, 25 Parsons Ave, Glen Waverley	239.25	''	06/12/00
Mr Donald Lindsay Robertson, PO Box 33-788, Takapuna, Auckland, New Zealand	179.64	''	03/07/00
Mr Hugh Graeme Robinson, 14 Tadema Crescent, Eltham	115.11	''	''
Est Late Gwenyth R. Roddick, C/o Mrs J. M. E. Angwin, 25 Hambleton Street, Albert Park	678.18	''	03/07/00
Est Late Gwenyth R. Roddick, C/o Mrs J. M. E. Angwin, 25 Hambleton Street, Albert Park	649.75	''	06/12/00
Mr Matthew Rodwell, 4 Jaeger Place, Woronora Heights, NSW	109.28	''	03/07/00
Mr Herrn Eberhard Rohr, Fustrasse 10 D-8 Munchen 19 Germany	110.24	''	''
Est Late Donald E. Rollason & Mr William B. Phillips, C/o Mr W. B. Phillips, 38 Milson Road, Cremorne, NSW	262.75	''	06/12/00
Est Late Donald E. Rollason & Mr William B. Phillips, C/o Mr W. B. Phillips, 38 Milson Road, Cremorne, NSW	272.55	''	03/07/00
Mr Roland Rosenbach, PO Box 1563, Potts Point, NSW	130.00	''	''
Mr Roland Rosenbach, PO Box 1563, Potts Point, NSW	125.00	''	06/12/00
Est Late Joan Louise Rosenwax, C/o Mr Grant Prichard Duffield & Duffield, GPO Box 1216, Sydney, NSW	111.67	''	03/07/00
Mr James William Rothwell, 26 Matheson Drive, Pretty Pool, Port Hedland, WA	159.61	''	''
Mr James William Rothwell, 26 Matheson Drive, Pretty Pool, Port Hedland, WA	146.25	''	06/12/00
Mrs Hester F. Rouse, 26 Bullinda Street, Dunedoo, NSW	482.22	''	03/07/00
Mrs Hester F. Rouse, 26 Bullinda Street, Dunedoo, NSW	454.25	''	06/12/00
Miss Nicolin Rowan, 47 Park Street, Goulburn, NSW	111.50	''	''
Miss Nicolin Rowan, 47 Park Street, Goulburn, NSW	114.93	''	03/07/00
Mrs Lesley Yvonne Rowe, 1 Meakin Street, East Geelong	146.50	''	06/12/00
Est Late John Peter D. Rowley, C/o Rowlandson & Co, PO Box 275, Castle Hill, NSW	285.06	''	03/07/00
Est Late John Peter D. Rowley, C/o Rowlandson & Co, PO Box 275, Castle Hill, NSW	274.50	''	06/12/00
Mr John Roxby, 177 Stanley Rd, Teddington, Middlesex, UK	321.50	''	''
Mr Neil James Roy, Moonlight No 3 R D, Palmerston, Otago, New Zealand	165.88	''	03/07/00
Mr Neil James Roy, Moonlight No 3 R D, Palmerston, Otago, New Zealand	159.50	''	06/12/00
Est Late Isaac Rudzki, C/o Fay Rudzki, 15 Jessamine Avenue, Windsor	361.66	''	03/07/00
Est Late Isaac Rudzki, C/o Fay Rudzki, 15 Jessamine Avenue, Windsor	347.75	''	06/12/00
Rush Cutters Productions Pty Ltd, "Super Benefit Fund A/c", 4/14 Dickson Avenue, Artarmon, NSW	141.00	''	''
Rush Cutters Productions Pty Ltd, "Super Benefit Fund A/c", 4/14 Dickson Avenue, Artarmon, NSW	160.75	''	03/07/00
Mrs Joan Mary Russell, GPO Box 10245, Kuala Lumpur, Malaysia	915.20	''	''
Est Late Anthony B. Rust Jnr, C/o Johnson Taylor, GPO Box 607, Canberra, ACT	128.01	''	''

Est Late Anthony B. Rust Jnr, C/o Johnson Taylor, GPO Box 607, Canberra, ACT	113.75	”	06/12/00
R. W. Corlett Pty Ltd, 30 Oleander Avenue, Figtree, NSW	260.00	”	03/07/00
Wing Cmdr Michael Richard Ryan, 6 Seaview Crescent, Altona	439.40	”	”
Wing Cmdr Michael Richard Ryan, 6 Seaview Crescent, Altona	422.50	”	06/12/00
Ms Samantha Ann Ryan, 13 Carlisle Street, Rose Bay, NSW	192.40	”	03/07/00
Rylake Investments Pty Ltd, Level 7, Gateway 1, Macquarie Place, Sydney, NSW	275.00	”	06/12/00
Est Late Stanley Saber, C/o Mrs B. Giveen, PO Box 137, Dee Why, NSW	276.00	”	”
Mr Thomas Harbutt Salmon, 7 Awanui Street, Birkenhead, Auckland, New Zealand	385.25	”	”
Miss Christine Eve Salvaris, 16 Yarra Street, Hawthorn	100.92	”	03/07/00
Mr John Adrian Sambell, 11 Wilson Street, Glen Iris	222.50	”	06/12/00
Mr Peter Ross Samuel, 2/48 Preston St, Mangerton, NSW	143.75	”	”
Mr Peter Ross Samuel, 2/48 Preston St, Mangerton, NSW	159.32	”	03/07/00
Saralon Pty Limited, “Saralon Stf Sup Fnd A/c”, 5/44 Homebush Road, Strathfield, NSW	550.00	”	06/12/00
Ms Demelza Kate Sawyer, 309 Edinburgh Road, Castlecrag, NSW	196.25	”	”
Mr Donald Charles Schaefer, Lot 2, Rutledge Road, Jamberoo, NSW	339.40	”	03/07/00
Mr Donald Charles Schaefer, Lot 2, Rutledge Road, Jamberoo, NSW	324.00	”	06/12/00
Schmahmann Investments Pty Limited, C/o Barry Mendel Frank & Co Services Pty Ltd, Level 53, MLC Centre, Sydney, NSW	110.00	”	”
Schmahmann Investments Pty Limited, C/o Barry Mendel Frank & Co Services Pty Ltd, Level 53, MLC Centre, Sydney, NSW	114.40	”	03/07/00
Mr John Edward Schmidt & Mrs Jennifer Mary Schmidt, “J & J Schmidt Super Fund A/c, 39 Hills St, Pittsworth, Qld	340.61	”	”
Mr John Edward Schmidt & Mrs Jennifer Mary Schmidt, “J & J Schmidt Super Fund A/c”, 39 Hills St, Pittsworth, Qld	152.24	”	”
Ms Kim Schmidt, 7 Bruce Street, Beaumaris	151.50	”	”
Mr Peter Schnackenberg, 13 Gardenia Grove, Devonport, Tas.	120.96	”	”
Mrs Thekla Schoenfeld, 2/2 Colindia Ave, Neutral Bay, NSW	562.64	”	”
Mr David Paewai Schofield, 11 Gandawarra Crescent, Newman, WA	183.50	”	06/12/00
Est Late John Victor Scicluna, C/o Dr K. Mifsud Bonnig, 81 Trig Gyze Pace, Hamrun, Malta	292.50	”	”
Est Late John Victor Scicluna, C/o Dr K. Mifsud Bonnig, 81 Trig Gyze Pace, Hamrun, Malta	313.53	”	03/07/00
Est Late Kathleen May Scott, C/o Public Trustee NSW, PO Box 177, Burwood, NSW	455.26	”	”
Mr Justin Michael Scroope, 7 Kirrang Avenue, Mangerton, NSW	1,457.75	”	06/12/00

2514 G 38 19 September 2002

Victoria Government Gazette

Mrs Elsie May See, 6/412 Maroubra Road, Maroubra Beach, NSW	124.80	''	03/07/00
Mr John P. See, 412 Maroubra Rd, Maroubra Beach, NSW	333.75	''	06/12/00
Mr John P. See, 412 Maroubra Rd, Maroubra Beach, NSW	347.10	''	03/07/00
Mr Michael Selia, 293 Storey Street, Maroubra, NSW	250.00	''	06/12/00
Mr Bruce Albert Selvey, 3 Penelope Court, Benowa, Qld	159.00	''	''
Dr Ami C. Setu, PO Box 506, Yeppoon, Qld	282.50	''	''
S. F. Schofield Pty Ltd, "A/c Superannuation Fund", C/o Belleville Remond & Co, 322 Little Lonsdale Street, Melbourne	776.75	''	''
Miss Kristine Elizabeth Shand, 42 Pulham Crescent, Hamilton, New Zealand	178.50	''	06/12/00
Miss Kristine Elizabeth Shand, 42 Pulham Crescent, Hamilton, New Zealand	185.64	''	03/07/00
Mr Michael Reginald Sharman & Mrs Frances Stuttaford & Mr Roland Brinton, "FSC A/c", 235 King Street, Hammersmith, London W6 9LP UK	292.25	''	06/12/00
Mr Michael Reginald Sharman & Mr Frances Stuttaford & Mr Roland Brinton, "H A/c", 235 King Street, Hammersmith, London W6 9LP UK	584.25	''	''
Shawnee Holdings Pty Ltd, 5 Ellerslie Crescent, Taringa, Qld	102.47	''	03/07/00
Shawnvale Pty Ltd, Private Bag 19, Kalgoorlie, WA	1,659.75	''	06/12/00
Miss Sarah Caroline Sheales, 2 Acheron Ave, Camberwell	291.75	''	''
Mr Michael Shearer & Mrs Mary Millington, "Est Jean Lemessurier A/c", PO Box 194, Stepney, SA	145.00	''	03/07/00
Mrs Cynthia Rea Shepherd, Yew Tree Cottage, Witherenden Hill, Burwash Etchingham, East Sussex TN19 7JN United Kingdom	224.25	''	06/12/00
Mr Lloyd William Shepherdson & Mrs Elizabeth Ann Shepherdson, PO Box 216, Margaret River, WA	142.48	''	03/07/00
Mr Eugene Sherry, 25 Ridge Street, Gordon, NSW	107.75	''	06/12/00
Mr Eugene Sherry, 25 Ridge Street, Gordon, NSW	124.29	''	03/07/00
Mr James Raymond Shipway, PO Box 1045, Epping, NSW	198.55	''	''
Miss Elizabeth Anne Short, 1083 Nepean Highway, Rosebud	541.32	''	''
Miss Elizabeth Anne Short, 1083 Nepean Highway, Rosebud	520.50	''	06/12/00
Mr David Shute, 2/42 Sherwood Court, Lindisfarne, Tas.	103.49	''	03/07/00
Miss Sala Sihombing, 19 Aird Street, Camberwell	124.15	''	''
Miss Sala Sihombing, 19 Aird Street, Camberwell	108.00	''	06/12/00
Mrs Margaret Simmons. PO Box 134. Albert Park	142.00	''	''
Mrs Margaret Simmons. PO Box 134. Albert Park	147.30	''	03/07/00
Mr Andrew Drayton Simpson, 19 Mawhera Avenue, Sandy Bay, Tas.	120.46	''	''
Mr Andrew Drayton Simpson, 19 Mawhera Avenue, Sandy Bay, Tas.	116.00	''	06/12/00
Est Late Ellen C. Simpson, C/o Heather Simpson, 16 Fitzroy Street, Wadestown, Wellington, NZ	1,187.16	''	03/07/00
Mrs Sandra Janet Simpson, 145 Cedric Street, Stirling, WA	100.00	''	06/12/00
Mrs Sascha Sinclair, 17 Allingham Court, Haverstock Hill, London NW3 United Kingdom	156.75	''	''
S. J. Fox Homes Pty Ltd, "Superannuation Fund A/c", 24 McCullagh Crescent, Narangba, Qld	346.84	''	03/07/00
S. J. Opie & Associates Pty Ltd,			

<i>Victoria Government Gazette</i>	<i>G 38</i>	<i>19 September 2002</i>	<i>2515</i>
"S J Opie Family A/c", 77 Freemantle Drive, Wantirna South S. J. Opie & Associates Pty Ltd,	115.11	"	"
"S J Opie Family A/c", 77 Freemantle Drive, Wantirna South Miss Lisa Jan Skelton & Mr Andrew Mark Skelton & Miss Kerri Anne Skelton & Miss Merylyn Clayre Skelton, 35 Grosvenor Street, Brighton	103.25	"	06/12/00
Miss Lisa Jan Skelton & Mr Andrew Mark Skelton & Miss Kerri Anne Skelton & Miss Merylyn Clayre Skelton, 35 Grosvenor Street, Brighton	113.62	"	03/07/00
Mrs Julie Ann Skerrett, 17 Chrystobel Crescent, Hawthorn Skymist Investments Pty Ltd, Level 6, 332 St Kilda Road, Melbourne	109.25	"	06/12/00
Skymist Investments Pty Ltd, Level 6, 332 St Kilda Road, Melbourne	545.00	"	"
Mrs Jennifer Elspeth Sladden, C/o W. J. .I Cowan, 3/6 Heaton Terrace, Brooklyn, Wellington, New Zealand	130.00	"	03/07/00
Mrs Patricia May Slattery, PO Box 602, Camberwell	125.00	"	06/12/00
Mrs Georgina Mary Sligo, 152 Bonney Ave, Clayfield, Qld Smallacombe Nominees Pty Ltd, C/o Duesburys Services Pty Ltd, GPO Box 2450V, Melbourne	5,571.18	"	03/07/00
Est Late Laura W. Smallman, C/o T. H. Walker, PO Box 255, Forestville, NSW	102.96	"	"
Miss Alexandra Ives Smith, 35 Albert Street, Gladesville, NSW	798.75	"	06/12/00
Mr Colin Robert Smith, 69 Asling Street, Gardenvale	899.50	"	06/12/00
Mr Colin Robert Smith, 69 Asling Street, Gardenvale	1,242.50	"	"
Mr Ian Smith, C/o Procon Indah Graha Aktiva, Jalan Hr Rasuna Said Kuninga, Indonesia	101.00	"	"
Mr Ian Smith, C/o Procon Indah Graha Aktiva, Jalan Hr Rasuna Said Kuninga, Indonesia	302.12	"	03/07/00
Mrs Valerie Lilian Smith, C/o Herkess & Partners, 62 Buckingham Street, Surry Hills NSW	290.50	"	06/12/00
Dr William A. Smith, 22 Dutton Street, Walkerston, Qld	300.00	"	"
Dr William A. Smith, 22 Dutton Street, Walkerston, Qld	312.00	"	03/07/00
Mr Leslie William Sobey, 857 Lamport Crescent, Albury, NSW	693.50	"	06/12/00
Mr Leslie William Sobey, 857 Lamport Crescent, Albury, NSW	114.75	"	"
Miss Pamela D. Solomon, 7 Dickinson Ave, Croydon, NSW	122.81	"	03/07/00
Miss Pamela D. Solomon, 7 Dickinson Ave, Croydon, NSW	239.75	"	06/12/00
Mr Jason Lewis Sowerby, 37 Fullerton St, Stockton, NSW	249.09	"	03/07/00
Mr Jason Lewis Sowerby, 37 Fullerton St, Stockton, NSW	362.31	"	"
Mr Russell William Spargo & Mr Ian James Spargo, "Bonnyglen Retire Fund A/c", C/- Macquarie Advisory Group, PO Box 464, Kew	336.75	"	06/12/00
Mrs Hamidah Deidre Spiers, C/o Lloyds Bank Ltd, 16 St Jame/s Street, London SW1 United Kingdom	160.70	"	03/07/00
Mr Eugene Spitzer, 8 Lowana Avenue, Roseville, NSW	155.00	"	06/12/00
Mr Eugene Spitzer, 8 Lowana Avenue, Roseville, NSW	166.25	"	"
Mrs Janine Maree Spooner, 22 Cassegrain Close, Tingira Heights, NSW	104.00	"	"
	112.75	"	"
	116.86	"	03/07/00
	275.00	"	06/12/00

2516 G 38 19 September 2002

Victoria Government Gazette

Mr Robert Sprawson & Mr Paul Sheridan, C/o 5 Chancery Lane, Clifford's Inn, London EC4A 1BU UK	825.00	''	''
Mrs Patricia Spring, 3A Edward Street, Gordon, NSW	295.10	''	03/07/00
Mrs Patricia Spring, 3A Edward Street, Gordon, NSW	283.75	''	06/12/00
Mr John Mcgregor Squire, "A/c T/Tee Rachel Claire White", PO Box 2097, Bendigo	110.53	''	03/07/00
Stanham Pty Ltd, 22 Nelson Street, Gordon, NSW	643.50	''	''
Stanham Pty Ltd, 22 Nelson Street, Gordon, NSW	618.75	''	06/12/00
Mrs Anne Steele, 4/19-21 Dumaresq Street, Gordon, NSW	221.75	''	''
Est Late John Anthony Stern, C/o Lloyds Bank Limited, PO Box 132, 1 Butler Place, London SW1H 0PR UK	296.25	''	''
Mrs Phyllis Miriam Stevenson, 97 Ocean Parade, The Entrance, NSW	375.00	''	''
Mrs Phyllis Miriam Stevenson, 97 Ocean Parade, The Entrance, NSW	390.00	''	03/07/00
Mrs Doreen E. Stewart, 2 Cardwell Street, Bombala, NSW	160.07	''	''
Est Late Elizabeth C. Stewart, C/o Hill Osborne & Co, Auburn House, 8 Upper Piccadilly, Bradford BD1 3NU United Kingdom	170.50	''	06/12/00
Mrs Lisa Ann Stewart, Private Bag 16, Camberwell PO	138.84	''	03/07/00
Mrs Lisa Ann Stewart, Private Bag 16, Camberwell PO	133.50	''	06/12/00
Mr Michael Stoop, Calcot Grange, Reading RG31 7RS UK	176.25	''	''
Mr Christopher Stuart Stopp, 7/11 Beechworth Road, Sandy Bay, Tas.	109.20	''	03/07/00
Mr Christopher Stuart Stopp, 7/11 Beechworth Road, Sandy Bay, Tas.	105.00	''	06/12/00
Mr Harold W. Stott, 17 Boonal Street, Baulkham Hills, NSW	101.50	''	''
Mr Barry Robert Strachan, 36 Point Street, Bulli, NSW	250.00	''	''
Mrs Edna Margaret Strange, 3 Leigh St, Mandurah, WA	1,633.50	''	''
Mrs Edna Margaret Strange, 3 Leigh St, Mandurah, WA	1,698.84	''	03/07/00
Est Miss Carole Strauss, C/-SLC Investment Services Pty Ltd, PO Box 286, Deepdene D C, Balwyn	414.25	''	06/12/00
Mrs Janet Rosemary M. Subagio, 3 Heywood Avenue, Unley Park, SA	2,409.91	''	03/07/00
Mrs Janet Rosemary M. Subagio, 3 Heywood Avenue, Unley Park, SA	2,314.75	''	06/12/00
Suhari Nominees Pty Ltd, "H. P. Dahm Family A/c", 34 Hermitage Road, Auldana, SA	130.00	''	03/07/00
Mr David Timothy W. Sullivan & Mrs Rowen Audrey Sullivan, 7 Maroochy Waters Drive, Maroochydore, Qld	274.30	''	''
Surface Finishes Holdings Pty Ltd, PO Box 484, Lindfield, NSW	164.84	''	03/07/00
Surface Finishes Holdings Pty Ltd, PO Box 484, Lindfield, NSW	158.50	''	06/12/00
Mr Darren James Sutherland, 3/42 Greenacre Road, Wollongong, NSW	152.11	''	03/07/00
Mr Darren James Sutherland, 3/42 Greenacre Road, Wollongong, NSW	141.50	''	06/12/00
Mr Anthony Sutton & Mr Peter Sutton, 255 Birmingham Road, Walsall, West Midlands UK	633.25	''	''

Mr John Michael Sutton & Mrs Joan Carol Sutton, 7 Taft Place, Bonnet Bay, NSW	317.72	”	03/07/00
Mr John Michael Sutton & Mrs Joan Carol Sutton, 7 Taft Place, Bonnet Bay, NSW	305.50	”	06/12/00
Mr Stephen John Sutton, 92 Elizabeth Street, Mayfield, NSW	284.75	”	”
Mr Noel Barry Swadling & Mrs Carole Jean Swadling, 20A Merriman Street, Kyle Bay NSW	137.50	”	”
Swanban Pty Ltd, “Cobbadah Super Fund A/c”. 60 Golden Grove, Beacon Hill, NSW	164.84	”	03/07/00
Sweco Pty Limited, PO Box 251, Killara, NSW	250.00	”	06/12/00
Mr Francis Phillip Sweet, 2/39 Quinton Road, Manly, NSW	105.04	”	03/07/00
Mr Francis Phillip Sweet, 2/39 Quinton Road, Manly, NSW	101.00	”	06/12/00
Mrs Margaret Szasz, 8 Orana Avenue, Pymble, NSW	206.25	”	”
Mrs Margaret Szasz, 8 Orana Avenue, Pymble, NSW	213.92	”	03/07/00
Mr Behnam Tai & Mrs Marian Tai, 206 Narra Valley Drive, Niagara Park, NSW	102.75	”	06/12/00
Mr Toyoshi Takakuwa, 1-20-2-6061 Nakamachi Musashino-Shi, Tokyo, Japan	340.25	”	”
Mr Toyoshi Takakuwa, 1-20-2-6061 Nakamachi Musashino-Shi, Tokyo, Japan	357.19	”	03/07/00
Mr Andrew Gie Tan, 4 Elgin Street, Grey Lynn, Auckland, NZ	240.00	”	06/12/00
Ms Harlene Mignon Tancred, 3/97 Chadstone Road, East Malvern	601.92	”	03/07/00
Mrs Ursula Sian Tankard, Old Vicarage Lightcliffe, West Yorkshire HX3 8TH United Kingdom	275.00	”	06/12/00
Mrs Elizabeth Mary L. Tapley, 100 East Ave, Beverley, SA	299.25	”	”
Mr Roger Quentin P. Tarrant, C/o Bank of NSW, PO Box 104, Glenroy	116.86	”	03/07/00
Mr Roger Quentin P. Tarrant, C/o Bank of NSW, PO Box 104, Glenroy	112.75	”	06/12/00
Mr Adrian Paul Tavan, 30 Oliver Place, Berkeley, NSW	130.00	”	03/07/00
Mr Alan Richard Taylor, C/o Info-Med Limited, K K Centre, 10th Floor, 46-54 Temple Street, Yaumatei Kowloon, Hong Kong	184.32	”	”
Mr Alan Richard Taylor, C/o Info-Med Limited, K K Centre, 10th Floor, 46-54 Temple Street, Yaumatei Kowloon, Hong Kong	165.50	”	06/12/00
Mr Daniel Charles Taylor, 17 Tudor Street, Dulwich, SA	108.50	”	”
Mr Geoffrey Norman F. Taylor, 302 Moore Park Road, Paddington, NSW	136.11	”	03/07/00
Mr Hugh Marshall Taylor, “A/C Euan J. M. Taylor”, 106 Loudoun Road, Newmilns, Ayrshire, United Kingdom	106.00	”	06/12/00
Technica Tooling Pty Ltd, “Super Fund A/c”, 6-8 Marker Avenue, Marlestone, SA	129.00	”	”
Teskelle Pty Limited, “The Critchley Family A/c”, PO Box 495, Balwyn North	275.00	”	”
Teskelle Pty Limited, “The Critchley Family A/c”, PO Box 495, Balwyn North	286.00	”	03/07/00
Tetelestai Pty Ltd, 305 High Street, Prahran	104.00	”	”
Tetelestai Pty Ltd, 305 High Street, Prahran	100.00	”	06/12/00
Thames Water Authority, “If A/c”, New River Head, Rosebery Avenue, London EC1R 4TP United Kingdom	359.00	”	”

2518 G 38 19 September 2002

Victoria Government Gazette

Ms Katarina Thome, Marsden Marine, Chinatown Point, 133 New Bridge Road, Singapore	2,725.50	”	”
Ms Katarina Thome, Marsden Marine, Chinatown Point, 133 New Bridge Road, Singapore	2,841.20	”	03/07/00
Mrs Elizabeth Jane H. Thompson, 110 Arabella Street, Longueville, NSW	816.73	”	”
Mr Derek Steven Thomson, 37/2 Macarthur Road, Parkville	270.45	”	”
Ms Jennifer Merry Thomson, 2/24 Gilles Road, Glen Osmond, SA	129.48	”	”
Mr George Edward Thornell & Mrs Brenda Anastasia Thornell, C/o Hopkins & Davie, PO Box 129, Cowes	181.50	”	06/12/00
Mrs Lesley Margaret Thorpe, 4/325 Walker Street, Ballarat North	227.16	”	03/07/00
Mrs Lesley Margaret Thorpe, 4/325 Walker Street, Ballarat North	205.00	”	06/12/00
Mr John Charles Thurling, 1/99 Dorking Road, Box Hill	132.60	”	03/07/00
Mrs Eunice Mary Tindley, 46 Gilarth Street, Highett	681.25	”	06/12/00
Mr Anthony James Bavin Tod, “Tulloch Brae”, M S 918, Toowoomba, Qld	1,253.75	”	”
Mrs Janet G. Todd, Foxton Lodge, Foxton Close, Oxford OX2 8LB United Kingdom	3,625.00	”	”
Mrs Susanna Louisa Todd, 54 Queens Road, Beckenham, Kent BR3 4JL UK	115.75	”	”
Mr William Andrew Todd, 51 Whitsunday Drive, Hoppers Crossing	292.75	”	”
Mrs Janet Patricia Tomlinson, 105 Stanlake Road, Shepards Bush, London W12 7HQ UK	538.25	”	”
Tor Investments Ltd, 19th Floor, Nine Queen’s Road, Central Hong Kong	204.62	”	03/07/00
Tor Investments Ltd, 19th Floor, Nine Queen’s Road, Central Hong Kong	196.75	”	06/12/00
Mr John Francis Townsend, 4 Mimulus Place, Caringbah, NSW	275.00	”	”
Mrs Yuiko Toyoda, 22-6 Sengoku 3-Chome Bunkyo-Ku Tokyo, Japan	528.99	”	03/07/00
Traditional Medicine Supplies Pty Limited , “Jesol Super Fund A/c”, PO Box 692, Bondi Junction, NSW	562.64	”	”
Traditional Medicine Supplies Pty Limited , “Jesol Super Fund A/c”, PO Box 692, Bondi Junction, NSW	541.00	”	06/12/00
Mr Slobodan Trbojevich, “Super Fund A/c”, 5 Jamieson Avenue, North Curl Curl, NSW	129.00	”	”
Ms Claire Isobel Treloar, 99A Waitapa Road, Hataitai, Wellington, New Zealand	887.12	”	03/07/00
Ms Claire Isobel Treloar, 99A Waitapa Road, Hataitai, Wellington, New Zealand	853.00	”	06/12/00
Mr Allan L. Trethewey, West Nombi, Mullaley, Via Gunnedah, NSW	1,562.50	”	”
Trevor Knuckey Pty Ltd, “Superannuation Fund A/c”, PO Box 1082, Warragul	238.75	”	”
Trevor Knuckey Pty Ltd, “Superannuation Fund A/c”, PO Box 1082, Warragul	250.28	”	03/07/00
Mr Russell Triggs, 168 Bay Street, Brighton	176.00	”	06/12/00

Mr Clive Norman Trist & Mrs Helga Mary Trist, "A/c C N Trist Super Fund", 19 Jackson St, Balgowlah, NSW	147.30	"	03/07/00
Mr Clive Norman Trist & Mrs Helga Mary Trist, "A/c C N Trist Super Fund", 19 Jackson St, Balgowlah, NSW	142.00	"	06/12/00
Est Late Sylvia G. Truelove, PO Box 609, Southport, Qld	226.46	"	03/07/00
Est Late Sylvia G. Truelove, PO Box 609, Southport, Qld	217.75	"	06/12/00
Mr Vasso Paul Tsolakis, PO Box 1285, Maroubra Junction, NSW	232.18	"	03/07/00
Mr Morris Tuapiki, 35 Moke Place, Taharoa, R D 8 Te Kuiti, New Zealand	286.00	"	"
Mr Morris Tuapiki, 35 Moke Place, Taharoa, R D 8 Te Kuiti, New Zealand	275.00	"	06/12/00
Mr Edward Philip S. Tufton, 70 Perrymead Street, London SW6 United Kingdom	230.50	"	"
Mr Geoffrey John Turner & Mr Brian George Rose, C/o Fortune Manning & Ptns, PO Box 4139, Auckland, NZ	723.64	"	03/07/00
Est Late Leicester W. Turner, C/o Fortune Manning & Partners, PO Box 4139, Auckland, New Zealand	180.15	"	"
Mr Peter John Turner, 43 Euree Street, Reid, ACT	209.50	"	06/12/00
Mr Peter John Turner, 43 Euree Street, Reid, ACT	217.88	"	03/07/00
Mr Terence Edward Twomey, 44 Bassendean Parade, Bassendean, WA	548.38	"	03/07/00
Mr Terence Edward Twomey, 44 Bassendean Parade, Bassendean, WA	513.75	"	06/12/00
Est Late Geoffrey S. Udall, C/o Cauthery Waterman & Cheetham, 30 Old Market, Wisbech Cambs PE13 1NB United Kingdom	1,404.75	"	"
Miss Mirella Ugonotti, 51 Francis Street, Corrimal, NSW	112.75	"	"
Union Jack Photo Plays Ltd, C/o National Westminster Bank Limited, 25 Hampstead High Street, London NW3 United Kingdom	398.25	"	"
Unser Investments Pty Limited, 61-63 Oxford Street, Collingwood	109.72	"	03/07/00
Unser Investments Pty Limited, 61-63 Oxford Street, Collingwood	105.50	"	06/12/00
Up Here For Thinking Pty Ltd , C/o Mr Ian Watson, 49 Crown St, Woolloomooloo, NSW	286.00	"	03/07/00
Mr Roger John Usher & Mr Donald William Braxton, PO Box 3525, 9 Place Du Molard, Geneva, Switzerland	612.30	"	"
Mr Roger John Usher & Mr Donald William Braxton, PO Box 3525, 9 Place Du Molard, Geneva, Switzerland	588.75	"	06/12/00
Vanable Pty Ltd, "Peter Alter Super Fund A/c", C/o BMF Investments Services Pty Ltd, Level 53, MLC Centre, 19 Martin Place, Sydney, NSW	250.00	"	"
Mr Hugh William Van Asch & Mrs Peggy Doreen Van Asch, "Est Jnm Burbury A/c", PO Box 8434, Havelock North, NZ	250.00	"	"
Mr David Neam Vaughan, 4 Carramar Place, Glendale, NSW	121.75	"	"
Est Late Margaret H. Vere Vere, C/o Mr S. H. Woolfe Harvey Ingram, 20 New Walk, Leicester LE1 6TX United Kingdom	279.50	"	"

2520 G 38 19 September 2002

Victoria Government Gazette

Mr Andre Verhaegen, 130 Gontrode Heirweg, 9820 Merelbeke, Belgium	1,275.20	”	03/07/00
Mr Keith Versfeld & Mrs Sybil Versfeld, 46 Willowtree Crescent, Belrose NSW	284.43	”	”
Mrs Ellen Joyce Vicars, 23/114A Rawson Road, Guildford, NSW	135.25	”	06/12/00
Victoria Park Hill Pty Ltd, C/o Mulcahy Mendelson & Round, 1st Floor, 526 Whitehorse Road, Mitcham	3,470.00	”	”
Mr Geoffrey Vidal, PO Box 65, Macksville, NSW	113.58	”	03/07/00
Mr Geoffrey Vidal, PO Box 65, Macksville, NSW	102.50	”	06/12/00
Mr Wilbur John Campbell Vigus, PO Box 128, Glenroy	129.00	”	”
Mr Wilbur John Campbell Vigus, PO Box 128, Glenroy	133.90	”	03/07/00
Mr Neville George Villiers, 46 Kempzie Road, Upper Gravatt, Qld	191.74	”	”
Mr Efstratios Vitos, 29 Barbara Street, Moorabbin	112.00	”	06/12/00
Mr Efstratios Vitos, 29 Barbara Street, Moorabbin	116.48	”	03/07/00
Vjv Investments Pty Ltd, C/o B. Nankivell, GPO Box 2505, Adelaide, SA	158.50	”	06/12/00
V. K. Khurana Pty Ltd, “Pension Fund A/c”, 1/161 George Street, Liverpool, NSW	176.00	”	”
V. K. Khurana Pty Ltd, “Pension Fund A/c”, 1/161 George Street, Liverpool, NSW	182.94	”	03/07/00
Mr Dalichand Jechand Vora & Mrs Pranvanti Dalichand Vora, PO Box 1674, Nakuru, Kenya	115.75	”	06/12/00
Mr Dalichand Jechand Vora & Mrs Pranvanti Dalichand Vora, PO Box 1674, Nakuru, Kenya	120.38	”	03/07/00
Mr John Scott Waddington, 3A Robin Parade, Beaconsfield Road, Farnham, Common Bucks SL2 3QL United Kingdom	205.75	”	06/12/00
Est Late Gordon Stanley Wade, 30A Thomson Road, Claremont, WA	551.75	”	”
Mr George Chong Wah & Mr Arthur Chong Wah & Mr Charles Chong Wah, PO Box 42684, Casuarina, Darwin, NT	150.75	”	06/12/00
Mr George Chong Wah & Mr Arthur Chong Wah & Mr Charles Chong Wah, PO Box 42684, Casuarina, Darwin, NT	157.19	”	03/07/00
Mr Wong Chi Wai, C/o GPO Box 2199, Hong Kong	1,657.76	”	”
Mr Colin Robert Neal Wald, “Thomas D. & Gemma C. G. Wald A/c”, “Windouran”, PO Box 38, Harden, NSW	125.25	”	06/12/00
Mr Ian John Walker, 220/34 Peninsula Rd, Maylands, WA	153.50	”	”
Mr Ian John Walker, 220/34 Peninsula Rd, Maylands, WA	159.64	”	03/07/00
Mr Nicholas Francis Walker, PO Box 3062, Geelong	152.02	”	”
Mr Alexander John Wallace, 8 Mingara Ave, Stonyfell, SA	1,249.50	”	06/12/00
Mr Alexander John Wallace, 8 Mingara Ave, Stonyfell, SA	1,298.78	”	03/07/00
Miss Annette Michelle Wallace, PO Box 38109, Winnellie, NT	142.00	”	06/12/00
Miss Annette Michelle Wallace, PO Box 38109, Winnellie, NT	147.30	”	03/07/00
Mr Bradley John Walls, 16 St Austell Road, Belgrave South	133.25	”	06/12/00

Mr Robert William Walsh, PO Box 375, Ruidoso, Nm 88355 USA	371.75	''	''
Mrs Pamela Dorothy Walter, C/o J. O. Blades, Unit 61, Culter Village, Colooli Road, Narrabeen, NSW	128.75	''	''
Mrs Pamela Dorothy Walter, C/o J. O. Blades, Unit 61, Culter Village, Colooli Road, Narrabeen, NSW	133.90	''	03/07/00
Mr Barry Wamilat, PO Box 1113, Rabaul Enbp, Papua New Guinea	152.50	''	06/12/00
Mr Colin Graham Warren, 23 Koolyoo Street, Newman,	350.75	''	''
Mr John Waskom, 1/24 Glebe Street, Randwick, NSW	1,271.74	''	03/07/00
Mrs Dora Watkins, 874 Burke Road, Canterbury	705.13	''	''
Mrs Dora Watkins, 874 Burke Road, Canterbury	667.50	''	06/12/00
Mr Christopher John B. Watson, 69 Highlever Road, London W10 6PR United Kingdom	185.00	''	''
Est Late Doris Daphne Watts, PO Box 115, Lindfield, NSW	132.50	''	''
Est Late Doris Daphne Watts, PO Box 115, Lindfield, NSW	137.80	''	03/07/00
Mr John Russell Waugh, 5 Glebe Avenue, Cheltenham	332.99	''	''
Mr Alex Webb, 28/15 Herbert Street, St Leonards ,NSW	104.75	''	06/12/00
Miss Erica Kathleen Webster, 33 Gilderthorpe Avenue, Randwick, NSW	174.75	''	''
Est Late Alphonse Wedekind, C/o A C Fergusson & Partners, 20 Havelock Road, #03-15 Central Square, Singapore	1,598.27	''	03/07/00
Est Late Alphonse Wedekind, C/o A C Fergusson & Partners, 20 Havelock Road, #03-15 Central Square, Singapore	1,527.00	''	06/12/00
Mr Philip Christopher Weiss, 19 Avenue Hamoir, 1180 Brussels, Belgium	319.75	''	''
Mr Philip Christopher Weiss, 19 Avenue Hamoir, 1180 Brussels, Belgium	332.54	''	03/07/00
Mr Michael Robert Wellard, "Benjamin Robert Wellard A/c", 25 Vincent Street, Glen Iris	150.00	''	06/12/00
Mrs Evelyn Jean Wells, Tahuroa Road, No 1 Rd, Morrinsville, New Zealand	330.00	''	''
Mrs Evelyn Jean Wells, Tahuroa Road, No 1 Rd, Morrinsville New Zealand	346.87	''	03/07/00
Est Late Margaret Lilian Welsh, C/o Henderson Taylor Mitchell Baker, 18-20 York Street, Sydney ,NSW	249.00	''	06/12/00
Wesbran Pty Ltd, "Super Fund A/c", Shop 16, Mudgeeraba Market, Swan Lane, Mudgeeraba, Qld	258.87	''	03/07/00
Miss Deborah Waveny West, C/O Mrs Deborah Waveny Lee, 2 Norburn Street, Ladbrooke Grove, London W10 6EQ UK	108.00	''	06/12/00
Mr Kenneth Frederick S. West, 7 Beeches Drive, Erdington, Birmingham B24 ODU UK	112.32	''	03/07/00
Mr Ian Frank Wheatley, 33 Marsden Street, Kiama, NSW	206.25	''	06/12/00
Mr Ian Frank Wheatley, 33 Marsden Street, Kiama, NSW	148.25	''	''
Miss Mary Elizabeth Whelan, C/o VJ Ryan & Co Services P/L, NAB House, Level 5, 255 George Street, Sydney, NSW	314.43	''	03/07/00
Mr Martin White, 3 Ronald Avenue, Greenwich, NSW	301.75	''	06/12/00
Mr Stephen Joseph White & Mrs Louise Ann White, "A/c Superannuation Fund", C/o Poole & Partners, PO Box 206, Mooloolaba, Qld	100.92	''	03/07/00
Mr Stephen Joseph White & Mrs Louise Ann White, "A/c Superannuation Fund", C/o Poole & Partners, PO Box 206, Mooloolaba, Qld	318.00	''	06/12/00
Mr Stephen Joseph White & Mrs Louise Ann White, "A/c Superannuation Fund", C/o Poole & Partners, PO Box 206, Mooloolaba, Qld	192.22	''	03/07/00
Mr Stephen Joseph White & Mrs Louise Ann White, "A/c Superannuation Fund", C/o Poole & Partners, PO Box 206, Mooloolaba, Qld	176.50	''	06/12/00

2522 G 38 19 September 2002

Victoria Government Gazette

Est Late John J. Whitefield, C/o Mervyn J. Cathers & Co, PO Box 291, Castle Hill, NSW	131.50	''	''
Est Late John J. Whitefield, C/o Mervyn J. Cathers & Co, PO Box 291, Castle Hill, NSW	136.76	''	03/07/00
Mr Anthony John Whitehead, 30 Bostock Hall, Bostock Road, Bostock Middlewich, Cheshire CW10 9JN UK,	555.25	''	06/12/00
Mr John Davidson Whitehouse, 234 Desborough Avenue, High Wycombe, Bucks HP11 2Q2 United Kingdom	108.75	''	''
Est Late William W. Whitnall, C/o Overseas Probate Service, Park House, 33 Park Crescent, Erith, Kent DA8 3DF United Kingdom	275.00	''	''
Mr David Maunsell Whyte, 1/18 Bobart Street, Parramatta, NSW	126.50	''	''
Dr Barton Luke Wicksteed, 'uardry', Bellmont Forest Via Gunning, NSW	107.65	''	03/07/00
Mrs Annemarie Wilken, 50 Moulten Street, Ashgrove, Qld	1,300.00	''	''
Mr Gregory James Wilkinson, 384 Sydenham Street, Cloverdale, WA	130.00	''	''
Mr Gregory James Wilkinson, 384 Sydenham Street, Cloverdale, WA	125.00	''	06/12/00
Mr Roger Wilkinson, 31 Oakden Street, Pearcedale	322.62	''	03/07/00
Mr Alan Mark Williams, 18 Borang Place, Lakeview Estate, Shellharbour, NSW	100.00	''	06/12/00
Miss Mary Eileen Williams, PO Box 203, Wollongong East, NSW	585.00	''	03/07/00
Miss Mary Eileen Williams, PO Box 203, Wollongong East, NSW	562.50	''	06/12/00
Mr Thomas Graham Williams, 68 Bevan Street, Albert Park	278.00	''	''
Mr Alick G. Wilson, 16 Braithwaite Street, Karori, Wellington, New Zealand	325.50	''	''
Est Late Francis M. Wilson, 25 Panorama Street, West Ashgrove, Qld	291.11	''	03/07/00
Mr Garry Robert Wilson, Tapandua, 23 St Petersburg, Russia	125.00	''	06/12/00
Mrs Isobel Florence Wilson, 4 Quiggin Street, Wynyard, Tas.	272.50	''	''
Mr Stewart Joseph Wilson, PO Box 2706, Southport, Qld	260.00	''	03/07/00
Mrs Deece P Andree-Wiltens, 5 Woodley Avenue, Remuera, Auckland, New Zealand	175.00	''	06/12/00
Ms Helena Mary Wimpole, 25 Lyndhurst Crescent, Hawthorn	107.06	''	03/07/00
Ms Helena Mary Wimpole, 25 Lyndhurst Crescent, Hawthorn	103.00	''	06/12/00
Mr Damian Gray Windsor, 254 Glenmore Road Paddington NSW	131.56	''	03/07/00
Mr Damian Gray Windsor, 254 Glenmore Road Paddington NSW	126.50	''	06/12/00
Mr Neil Malcolm Winkelmann, 18 Richard Austen Crescent, Middlemount, Qld	125.00	''	''
Mr Geoffrey Bruce Winstone, PO Box 13251, Onehunga, Auckland New Zealand	540.54	''	03/07/00
Dr Kelvin Withers, 6 Macarthur Avenue, Pagewood, NSW	228.80	''	''
Dr Kelvin Withers, 6 Macarthur Avenue, Pagewood, NSW	215.25	''	06/12/00
Mrs Lesley Anne Withers, 6 Macarthur Avenue, Pagewood, NSW	148.20	''	03/07/00
Mrs Lesley Anne Withers, 6 Macarthur Avenue, Pagewood, NSW	142.50	''	06/12/00

Ms Gaile Maree Witt, 33 Tocal Rd, Bolwarra Heights, NSW	127.75	''	''
Mr Morris Neil Wockner, 16 Seeman St, Blackwater, Qld	270.68	''	03/07/00
Mr Morris Neil Wockner, 16 Seeman St, Blackwater, Qld	256.25	''	06/12/00
Mr Johnathan Wolf ,13 The Battlement, Castlecrag, NSW	162.50	''	''
Mrs Ada Sau Lan Ip Wong, "Edmund Wong A/c", Flat D, 8th Floor, Wilton Place, 18 Park Road, Hong Kong	103.00	''	''
Ms Cindie Ling Ling Wong, 5th Floor, Front Portion, 34 Tung Lo Wan Road, Causeway Bay, Hong Kong	175.00	''	''
Dr George Seow Choon Wong, 17 Astrid Hill, Singapore	3,007.68	''	03/07/00
Mr Julian Wontner, 11 Clarendon Cross, London W11 4AP United Kingdom	133.00	''	06/12/00
Mrs Virginia Jane Woodhouse, 3 Grecia Lane, Mosman, NSW	199.50	''	''
Mr Glenn Daryl Woodward, Private Bag 1, Brim	214.50	''	''
Mr Glenn Daryl Woodward, Private Bag 1, Brim	222.62	''	03/07/00
Mrs Sylvia Worthington, "Downswood", Three Chain Road, Mornington	528.58	''	''
Mrs Sylvia Worthington, "Downswood", Three Chain Road, Mornington	508.25	''	06/12/00
Mr John Wortley & Ms Alexandra Palk, 17 Amal Street, Rosh Haayin 48092 Israel	156.00	''	03/07/00
Mr Peter James Wreford, PO Box 6099, Hawthorn West	503.20	''	''
Mr Arthur Cecil Wright, C/o State Trustees, GPO Box 3008 FF, Melbourne	727.25	''	06/12/00
Mr Arthur Cecil Wright, C/o State Trustees, GPO Box 3008 FF, Melbourne	756.34	''	03/07/00
Mr David Nicholas Wright, C/o Max Fashions, Private Bag, Newmarket, Auckland, NZ	481.25	''	06/12/00
Mr David Nicholas Wright, C/o Max Fashions, Private Bag, Newmarket, Auckland, NZ	500.50	''	03/07/00
Mr Roger Norman Wyndham & Mr Rex Hoeben, "R. N. Wyndham Super Fund A/c", C/o Mr Rex Hoeben, GPO Box 5456, Sydney, NSW	139.62	''	''
Mr Wei Xie, 98 Cambridge Street, Berala, NSW	133.90	''	''
Mr Alexander S. Yakubchuk, BBP Minerals, Novoryazanskaya Street 38, Building 3, Moscow, Russia	286.00	''	''
Miss Suan H. Yap, #07-03 2 Ridgewood Close, Singapore	105.25	''	06/12/00
Mr Stuart David Yeaman, 51 Vagabond Crescent, McKellar, ACT	125.00	''	''
Ms Li-Anne Yellachich, Unit 28, 132 Mounts Bay Road, West Perth, WA	127.92	''	03/07/00
Mr Sidney Yenson, 35 Boomerang Road, Edensar Park, NSW	337.22	''	''
Miss Jean Marie Yinson, PO Box 61, Elwood	210.05	''	''
Miss Jean Marie Yinson, PO Box 61, Elwood	194.25	''	06/12/00
Miss Catherine Stella Young, Flat 2, Sycamore Mews, Orlando Road, Clapham, London SW40SY United Kingdom	125.00	''	''
Mr Micheal Yuen & Mr Anthony Yuen, C/o Mr Tim Ho, D. W. Sutherland & Partners, 11 Conder St, Burwood, NSW	257.25	''	''
Mr Micheal Yuen & Mr Anthony Yuen, C/o Mr Tim Ho, D. W. Sutherland & Partners, 11 Conder St, Burwood, NSW	267.54	''	03/07/00
Mr Junzaburo Yuri Mitsui & Co Australia Ltd, State Bank Centre, 52 Martin Place, Sydney, NSW	654.69	''	''

2524 G 38 19 September 2002

Victoria Government Gazette

Mr Junzaburo Yuri Mitsui & Co Australia Ltd, State Bank Centre, 52 Martin Place, Sydney, NSW	630.25	”	06/12/00
Miss Natalie Zai, PO Box 931, Strathfield, NSW	164.50	”	”
Zeus’hermes Pty Limited, “Zeus’hermes Super Fund A/c”, PO Box 12146, A’Beckett Street Post Office, Melbourne	1,137.24	”	03/07/00
Zeus’hermes Pty Limited, “Zeus’hermes Super Fund A/c”, PO Box 12146, A’Beckett Street Post Office, Melbourne	1,093.50	”	06/12/00
Mrs Claire Catherine Zippel, C/- Geoff Zippel Mobile Oil Australia, PO Box 4507, Melbourne	548.60	”	03/07/00
Mrs Claire Catherine Zippel, C/- Geoff Zippel Mobile Oil Australia, PO Box 4507, Melbourne	527.50	”	06/12/00
Zorn Nominees Limited, “FBE A/c”, Cheapside House, 138 Cheapside, London EC2V 6BJ UK	1,176.25	”	”
Zorn Nominees Limited, “HEF A/c”, Cheapside House, 138 Cheapside, London EC2V 6BJ UK	151.25	”	”
Zorn Nominees Ltd, Cheapside House, 138 Cheapside, London EC2V 6BJ United Kingdom	105.00	”	”

02164

CONTACT: BHP Billiton Share Department. Phone: 1300 656 780.

Unclaimed Moneys Act 1962

Register of Unclaimed Moneys held by the —

<i>Name of Owner on Books and Last Known Address</i>	<i>Total Amount Due to Owner</i>	<i>Description Of Unclaimed Money</i>	<i>Date when Amount first became Payable</i>
BHP BILLITON LIMITED			
	£		
Aib Nominees (Jersey)Ltd, PO Box 468, Aib House, Grenville Street, St Helier, Jersey, Channel Islands	49.57	Cheque	03/07/00
Mrs Hilary M. Akker, 15 Fairbourne Cobham, Surrey KT11 2BT UK	76.93	”	”
Mrs Marjorie Andrews, Carnesure House, Longstock, Stockbridge Hant SO20 6DP United Kingdom	166.37	”	”
Miss Penelope Jane Bache, 6 White Heather Terrace, Bovey Tracey, Devon TQ13 9HF United Kingdom	64.24	”	”
Est Late Frank R. C. Bagley, C/o Brewin Dolphin, 5 Giltspur Street, London EC1A 9BD United Kingdom	764.45	”	”
Mrs Priscilla Ann Meath-Baker & Mr John Corder Belfrage, Hasfield Court, Gloucester, United Kingdom	699.62	”	”
Bank of Scotland Central Nominees Limited, 81 George Street, Edinburgh EH2 3ES United Kingdom	251.91	”	”
Mr Bruce John Barnard, Cherry Cottage, Rectory Lane, Cromhall, Wootton Under Edge, Gloucester GL12 8AN UK	117.28	”	”

Est Late Aubrey Wallace Barr, C/o Harrisons Dudhia, 18 Church St, Rickmansworth Hertfordshire WD3 1DD UK	72.72	”	”
Est Late Michael E. Beesley, 59 Canons Drive, Edgware, Middlesex HA8 7RG UK	132.25	”	”
Mr Gerald M. Behrens, Basement Flat 10A, Kempsford Gardens, London SW5 United Kingdom	81.79	”	”
Mr Ian Cauther Broadley & Mrs Ishbel Robertson Broadley, Corran, Armadale Road, RHU Dunbartonshire G84 8LG UK	185.39	”	”
Mr Percy Brown & Mr Gerald David Adlestone, 16 St Annes Road, West St Annes-On-Sea Lancs FY8 1RE UK	163.28	”	”
Mr Neville Buch, 65 Altwood Road, Maidenhead, Berkshire SL6 4PS United Kingdom	346.98	”	”
Mr R. Mark Byers, Waterfoot House, Newcastle, Co Down United Kingdom	155.75	”	”
Mr May Walter Bygraves, 110 Roebuck House, Stag Place, London United Kingdom	174.38	”	”
Lady Hilary D. Cecil Cardross, C/o Westminster Bank Limited, South Kensington Branch, Old Brompton Road, London SW7 United Kingdom	134.53	”	”
Est Late John A. Bonham-Carter, C/o Kerseys, 32 Lloyds Avenue, Ipswich, Suffolk IP1 3HD UK	144.94	”	”
Mrs Deborah Gertrude Clipsham, The Hermitage, Norwich Road, Edgefield Melton Constable, Norfolk NR24 2AL United Kingdom	111.33	”	”
Clydesdale Bank Head Office Nominees Limited, 30 St Vincent Place, Glasgow G1 2HL United Kingdom	39.66	”	”
Est Late Michael B. Conran, C/o Ronald Fletcher & Co, 243 Elgin Avenue, Maida Vale, London W9 1NJ UK	67.80	”	”
Mr John M. Constance, 45 Fouracre Crescent, Downend Bristol, BS16 6PT United Kingdom	117.56	”	”
Mr David Alastair T. Cullen, Cherry Tree Cottage, Fyning Lane, Rogate Petersfield GU31 5DQ UK	60.18	”	”
Mr Michael Robert A. Cullen, 8 Blenheim Terrace, Bovey Tracey, Devon TQ13 9AT United Kingdom	60.28	”	”
Mr Thomas David Cumming, 2 Royston Road, Richmond, Surrey TW10 United Kingdom	118.97	”	”
Mr Charles W. A. Cunningham, Woodings Whitchurch, Hants RG28 7QT UK	43.82	”	”
Dai Yat Pty Ltd, 100 Alleyn Park, Dulwich, London SE21 8AH United Kingdom	173.09	”	”
Mrs Kathleen Davidson, 30 Middle Way, Summertown, Oxford, United Kingdom	39.16	”	”
Mrs Joan Dean Dunsmore, Fallowfield, Blagdon Bristol, Avon, United Kingdom	51.06	”	”
Mrs Marianne Louise De Giorgio, 12 Lena Gardens, London W6 7PZ United Kingdom	175.97	”	”
Mrs Jeanette M. De Groote, 43 Turney Road, Dulwich, London SE21 75A UK	142.36	”	”
Miss Sarah Lucy Deverell, 38 Rotherfield Road, Henley-On-Thames, Oxfordshire RG9 1NN United Kingdom	132.65	”	”
Est Late Russell R. Foreman, C/o Home Wilkinson & Lowry, Level 44, Nauru House, 80 Collins Street, Melbourne	38.86	”	”

2526 G 38 19 September 2002

Victoria Government Gazette

Mr John Michael Galbraith, 22 Elsee Road, Rugby CV21 3BA United Kingdom	107.76	”	”
Ms Imogen Judith St C. Goodier, 6 Victoria Road, Harborne, Birmingham B17 0AH UK	359.08	”	”
Ms Rosalind Ronan J. Goodier, 6 Victoria Road, Harborne, Birmingham B17 0AH UK	359.08	”	”
Est Late Lorna A. F. Gotto, C/o Ashton Graham, 81 Guildhall Street, Bury, St Edmunds, Suffolk IP33 1PZ UK	287.90	”	”
Major John Graham, 12/14 The Borough Crondall, Farnham Surrey, United Kingdom	110.34	”	”
Mr Abner J. Greshler, C/o Sydney Rose, 123 Streatfield Road, Kenton Harrow Middx UK	204.92	”	”
Miss Sylvia Grimm, 57 Corner Fielde Wavertree Road, Streatham Hill, London SW2 4TJ United Kingdom	435.97	”	”
Miss Mary Ethel Hartigan, 45 Oakwood Road, Hayling Island, Hants PO11 9AY United Kingdom	219.76	”	”
Lady Mary Josephine Hartwell, 16 Clifton Place, Brighton, East Sussex BN1 3FN United Kingdom	165.06	”	”
Mr John Hauser & Mr Oscar F. Boehringer & Mr Bruno Otto Cogliatti, C/o 44 Hertford Road, Digswell Welwyn Hertfordshire AL6 0DB UK	41.64	”	”
Est Late Ian Murray Hay & Mr James Alexander R. Comfort, “A/c ATF Est Thomas Hay”, ‘Moravia’, Milton of Culloden, Inverness 1VI 2NT United Kingdom	74.35	”	”
Mrs Jessie Eva Hayman, C/o Royal Bank of Scotland, Drummonds, 49 Charing Cross Rd, London SW1A 2DX UK	708.23	”	”
Mr Harold Berkeley Hazell, Parkside Residential Home, 74–76 Village Road, Enfield, Middlesex EN1 2EU UK	126.00	”	”
Est Late Jack F. H. Hinton, C/o Lloyd & Associates, 48 Onslow Gardens, London SW7 3PY United Kingdom	63.84	”	”
Ms Lesley Charlotte Hogarth, Prospect Cottage, Glaisdale, Whitby YO21 2PL United Kingdom	85.36	”	”
Est Late Cicely Anne Hollyoak, C/o Bevan Ashford, 41 St James Street, Taunton, Somerset TA1 1JR UK	603.86	”	”
Mr Johan M. Horsthuis, 4 Cronk Drean Douglas, Isle Of Man IM2 6AR	44.39	”	”
Mrs Margaret Dewar Jack, Ardoch Holding 15 West Cochno, Hardgate, Clydebank G81 6RT UK	121.64	”	”
Dr Ian McDonnell Jessiman, 17 Grange Drive, Chislehurst, Kent BR7 5ES United Kingdom	151.60	”	”
Mrs Elizabeth Jean Jones, 9 Ennerdale Close, Beverley Hills Leamington Spa Warwickshire CV32 6NW United Kingdom	109.05	”	”
Est Late Gladys Maud E. Jones, C/o Capel Cure Sharp Limited, Royal Exchange House, 100 Queen Street, Glasgow G1 3DL United Kingdom	127.59	”	”
Mrs Wilhelmina Kaneen, 26 Cronkbourne Road, Douglas, Isle of Man	160.50	”	”
Miss Jennifer M. King, 83 Victoria Park Road, London E9 United Kingdom	58.29	”	”
KRA Investment Company Limited, 41 Freame Way, Gillingham, Dorset SP8 4RA UK	43.62	”	”
Mrs Carolyn Anne Lake, 21 Hill Park Street, off Merton Lane, Highgate, London N6 6ND UK	49.07	”	”

Est Late Stephen Henry Lambert, C/o Miss Kim D. Knight, 14 Caxton Road, Wimbledon, London SW19 8SJ UK	115.64	”	”
Miss Margaret Rose Lambourne, Oakfield Whitchurch Nr Reading, Berks, United Kingdom	227.42	”	”
Mr David Landau, 56 Middleway, London NW11 UK	107.76	”	”
Ms Stephanie Helen Maitland-Lewis & Mr Richard Michael Fairbairn, “JB A/c”, 1 Bell Yard, London WC2A 2JP UK	241.20	”	”
Lindsays Trustees Limited, “A/c FRZ74”, 11 Atholl Crescent, Edinburgh EH3 8HE United Kingdom	239.81	”	”
Mr Adrian John Charles Hope, The Marquis of Linlithgow, Hopetoun House, South Queensferry, West Lothian, Scotland, UK	79.31	”	”
Mrs Susan Grace Lock, 7 The Paddocks, Bugbrooke, Northampton NN7 3QR United Kingdom	58.22	”	”
Mr Thomas Neilson Lord, 10446 Greendale Drive, Tampa Fl 33626-5304 USA	43.13	”	”
Miss Margaret Ann G. Lowe, The Old Post Office, 1 Maes-Yr-Afon, Llancarfan Barry S Glamorgan CF6 9AG United Kingdom	703.28	”	”
Est Late Harry Grant Maby, 21 Pewley Way, Guildford, Surrey GU1 3PX United Kingdom	144.91	”	”
Mrs Mary Agnes Mann, C/o Mrs D. J. Meier, Wyndham House, Coppice Way, Haywards Heath, W. Sussex RH16 4NN United Kingdom	193.72	”	”
Est Late Gwendolene M Mark, C/o Sternberg Thomas Clarke & Company, Provincial House, 218–226 Bishopsgate, London EC2M 4QD United Kingdom	67.22	”	”
Mr David Hatherly Matthews, Bank of Ireland, Donegal Place, Belfast, United Kingdom	86.35	”	”
Mrs Elizabeth Macl Matthews, The Manor House, Chenies, Rickmansworth, Hertfordshire WD3 6ER UK	69.40	”	”
Mr Paul Traill Mattison, C/o Letterwalton House, Ledaig, PaA37 1RY Argyll, United Kingdom	140.08	”	”
Mrs Jennifer Alison S. May, 1 Albany Place, North Street, St Andrews Fife KY16 9HH United Kingdom	475.07	”	”
Mr Arthor Brooks McGowen, 96 Nimbus Way, Studlands Park, Newmarket, Suffolk CB8 7BW UK	46.69	”	”
Mr Douglas William McGregor, Lyefield Farm, Forest Green Nr Dorking, Surrey, United Kingdom	133.70	”	”
Mrs Lois Geraldine Mead, 19 Park Avenue, Bideford, Devon EX39 2QH United Kingdom	127.49	”	”
Mrs Anne Margaret Mervis, Turret Lodge, 1 Routh Road, London SW18 3SW United Kingdom	144.88	”	”
Midland Nominees Limited, “A/c 34003298”, Mariner House, Pepys Street, London EC3N 4DA UK	285.22	”	”
Ms Lorraine Mitchelmore, 39 Prestwick Circle, Se Calgary AB T2Z 314 Canada	49.57	”	”
Est Late David John Morgan, C/o Dr Myfanwy Morgan, 4 Barclay Mews, 98 Cottenham Park Road, London SW20 0SZ UK	286.55	”	”
Mr Jonathon M. V. Hughes-Morgan, 26 Palmerston Road, East Sheen, London SW14 7PZ United Kingdom	362.85	”	”

2528 G 38 19 September 2002

Victoria Government Gazette

Mr Abdul Rahman Al-Mughni, PO Box 3671, 13037 Safat, Kuwait	158.32	”	”
Mrs Leonore Naftalin, 55 Fursecroft George Street, London W1H 5LG United Kingdom	809.57	”	”
Est Late Joseph D. D. Newton & Mrs Sandra Brown. “F A/c”, The Mill House, Framewood Road, Fulmer Bucks SL2 4QS United Kingdom	205.22	”	”
Mr Geoffrey William Raine, “Teeswater”, Strawgate Lane. Stapleton, Darlington Co, Durham DL2 2QL UK	51.25	”	”
Mr Scott Riley, GPO Box 2483, Sydney, NSW	115.10	”	”
Mr Jonathan Hugh Rose & Mr Michael Eliot G. Prince & Mr John Stewart Forster, 169 Preston Road, Brighton East, Sussex BN1 6AG United Kingdom	265.89	”	”
Mr John Roxby, 177 Stanley Rd, Teddington, Middlesex, UK	127.49	”	”
Est Late Christopher Sharkey, C/o Mr J. P. Sharkey, 12 Thornhill Close, Barton-Under-Needwood, Staffs, UK	920.10	”	”
Mr Paul Simmons, 12 Uplands Road, Barnet, Herts EN4 8NY United Kingdom	219.91	”	”
S. P. Angel (Nominees) Limited, Biiba House, 14 Bevis Marks, London EC3A 7NT United Kingdom	337.47	”	”
Mrs Hamidah Deidre Spiers, C/o Lloyds Bank Ltd, 16 St Jame/s Street, London SW1 United Kingdom	41.24	”	”
Est Late John Anthony Stern, C/o Lloyds Bank Limited, PO Box 132, 1 Butler Place, London SW1H 0PR UK	117.48	”	”
Mrs Ursula Sian Tankard, Old Vicarage Lightcliffe, West Yorkshire HX3 8TH United Kingdom	109.05	”	”
Mr Hugh Marshall Taylor, “A/c Euan J. M. Taylor”, 106 Loudoun Road, Newmilns, Ayrshire, United Kingdom	42.03	”	”
Thames Water Authority, “IF A/c”, New River Head, Rosebery Avenue, London EC1R 4TP United Kingdom	145.57	”	”
Mrs Janet G. Todd, Foxton Lodge, Foxton Close, Oxford OX2 8LB United Kingdom	1,437.50	”	”
Mr Edward Philip S. Tufton, 70 Perrymead Street, London SW6 United Kingdom	91.41	”	”
Est Late Geoffrey S. Udall, C/o Cauthery Waterman & Cheetham, 30 Old Market, Wisbech Cambs PE13 1NB UK	557.06	”	”
Union Jack Photo Plays Ltd, C/o National Westminster Bank Limited, 25 Hampstead High Street, London NW3 United Kingdom	157.93	”	”
Vindex Trustees Limited, “MMT A/c”, 151 St Vincent Street, Glasgow G2 5NJ United Kingdom	244.67	”	”
Mr John Scott Waddington, 3A Robin Parade, Beaconsfield Road, Farnham, Common Bucks SL2 3QL UK	81.59	”	”
Miss Deborah Waveny West, C/o Mrs Deborah Waveny Lee, 2 Norburn Street, Ladbroke Grove, London W10 6EQ UK	81.79	”	”
Est Late Peter K. Whitaker, Dolffynon Tanygroes, Cardigan Dyfed SA43 2JS United Kingdom	127.49	”	”
Est Late William W. Whitnall, C/o Overseas Probate Service, Park House, 33 Park Crescent, Erith, Kent DA8 3DF UK	109.05	”	”
Mrs Joan Margaret Wise Whistlers, Burn Shore Road, Rhu By Helensburgh, Dunbartonshire, United Kingdom	188.36	”	”
Miss Catherine Stella Young, Flat 2, Sycamore Mews, Orlando Road, Clapham, London SW40SY UK	49.57	”	”

02165

CONTACT: BHP Billiton Share Department, Phone: 1300 656 780.

Unclaimed Moneys Act 1962

Register of Unclaimed Moneys held by the —

<i>Name of Owner on Books and Last Known Address</i>	<i>Total Amount Due to Owner</i>	<i>Description Of Unclaimed Money</i>	<i>Date when Amount first became Payable</i>
BHP BILLITON LIMITED			
	US \$		
Est Late Lucile B. Adams, C/o Mrs Tracy Anne Gregg, 6256 Masefield Court, Alexandria VA 22304 USA	70.01	Cheque	03/07/00
Est Late Lucile B. Adams, C/o Mrs Tracy Anne Gregg, 6256 Masefield Court, Alexandria VA 22304 USA	59.67	"	06/12/00
Est Late Gwen R. A. Arnold, 6 Willow Spring Lane, Hanover NH 03755 USA	237.65	"	"
Est Late Gwen R. A. Arnold, 6 Willow Spring Lane, Hanover NH 03755 USA	278.84	"	03/07/00
Miss Catherine Alice Arther, 615 Mountain Road, Kinnelon, New Jersey 07405 USA	198.09	"	"
Miss Catherine Alice Arther, 615 Mountain Road, Kinnelon, New Jersey 07405 USA	168.05	"	06/12/00
Ms Diana Hammond Boniwell, 1522 Clear Water Drive, Mississauga, Ontario L5E 3A3 Canada	211.40	"	03/07/00
Bost & Co, PO Box 9118, Boston MA 02205 USA	144.47	"	06/12/00
Bost & Co, PO Box 9118, Boston MA 02205 USA	169.51	"	03/07/00
Ms Gail Margaret Bourne, 7 Sunset Vale, Singapore	91.63	"	06/12/00
Est Late Thomas V. Briggs, C/o James T. Ragan, PO Box 1112, Green Valley AZ 85622 USA	78.82	"	03/07/00
Mr Tucker L. Burling, 420 S Star Avenue, Tucson AZ 85719 USA	261.30	"	"
Mr Tucker L. Burling, 420 S Star Avenue, Tucson AZ 85719 USA	222.70	"	06/12/00
Mrs Sue Buyer, "Martha Ruth Buyer A/c", 110 Woodland East, Aurora NY 14052 USA	229.91	"	"
Col John P. Canby, 8618 Eaglecrest Boulevard, San Antonio TX 78239-2611 USA	81.96	"	03/07/00
Col John P. Canby, 8618 Eaglecrest Boulevard, San Antonio TX 78239-2611 USA	69.85	"	06/12/00
C D & Co Incorporated, C/o Kidder Peabody & Co Inc 10, Hanover Square, New York 10005 USA	60.34	"	03/07/00
CDL Investors Inc., Attn: Lewis Avery, PO Box 6974, Macon Georgia 31208 United States of America	64.44	"	06/12/00
CDL Investors Inc., Attn: Lewis Avery, PO Box 6974, Macon Georgia 31208 United States of America	75.61	"	03/07/00
Mr Ashley Francis Chan, C/o UBS Securities Inc., 299 Park Avenue, New York NY 10171-0026 USA	83.17	"	"
Mr Ashley Francis Chan, C/o UBS Securities Inc., 299 Park Avenue, New York NY 10171-0026 USA	70.88	"	06/12/00
Dr Rom Charmin, 724 Royal Dublin Lane, Dyer IN 46311 USA	4,432.59	"	03/07/00

2530 G 38 19 September 2002

Victoria Government Gazette

Customers Company Inc., Morgan Guaranty Trust Company, 23 Wall Street, New York NY 10003 USA	83.47	”	”
Customers Company Inc., Morgan Guaranty Trust Company, 23 Wall Street, New York NY 10003 USA	71.14	”	06/12/00
Customers Company Inc., Morgan Guaranty Trust Company, 23 Wall Street, New York NY 10003 USA	154.09	”	03/07/00
Customers Company Inc., Morgan Guaranty Trust Company, 23 Wall Street, New York NY 10003 USA	131.32	”	06/12/00
Mr George T. Darling, 39 Brook Road, Sharon, Mass 02067 USA	119.40	”	03/07/00
Mr George T. Darling, 39 Brook Road, Sharon, Mass 02067 USA	100.26	”	06/12/00
Mrs Maria Theresa Dewied, PO Box 801506, Dallas TX 75380-1506 USA	253.14	”	03/07/00
Mr Anthony John Dietz, 143 31st Avenue, San Mateo CA 94403 USA	99.62	”	06/12/00
Donaldson Lufkin and Jenrette Inc, 120 Broadway, New York 10005 USA	62.91	”	03/07/00
Mrs Edith E. Doyle, 81-905 Corydon Avenue, Winnipeg, Manitoba R3M 353 Canada	115.21	”	06/12/00
Mr Frederick Drury Jnr, 803 Terra California Drive, Apt 3, Walnut Creek, California 94595 USA	93.05	”	”
Mrs Jane Olga Ebinger, 221 13th Street Se Washington DC 20003 USA	64.44	”	”
Mr David W. Edward, 2523 Lake Street, San Francisco, California 94121 USA	99.49	”	”
Mr David W. Edward, 2523 Lake Street, San Francisco, California 94121 USA	116.74	”	03/07/00
Mr Manuel Agapito Eguiluz, Av San Martin, 301 Urb Vallecito, Arequipa Peru	64.44	”	06/12/00
Mr Roger Anthony Ellis, Hc62 Box 1051 Honesdale PA 18431 USA	145.02	”	03/07/00
Miss Natalie Faine McCarthy, PO Box Mxy Glennallen Alaska 99588 USA	189.17	”	”
Mr Graham Farquharson, 12th Floor, 20 Toronto Street, Toronto, Ontario M5C 2B8 Canada	66.11	”	06/12/00
Mr Louis V. Ferraro, 3730 South Cuyler Berwyn IL 60402 USA	278.24	”	”
Mr Louis V. Ferraro, 3730 South Cuyler Berwyn IL 60402 USA	326.48	”	03/07/00
Est Late Florence Fischer, C/o Thomas V. Fischer, PO Box 311, Wayne IL 60184 USA	99.49	”	06/12/00
Est Late Florence Fischer, C/o Thomas V. Fischer, PO Box 311, Wayne IL 60184 USA	116.74	”	03/07/00
Mrs Maria Luisa Fornari, 2 Rivers Drive, Great Neck, New York 11020 USA	198.09	”	”
Mrs Maria Luisa Fornari, 2 Rivers Drive, Great Neck, New York 11020 USA	168.05	”	06/12/00
Mr Warren C. Gerig, 162 Dorchester Drive, Vincentown, New Jersey 08088 USA	121.43	”	03/07/00

Mr Warren C. Gerig, 162 Dorchester Drive, Vincentown, New Jersey 08088 USA	103.49	”	06/12/00
Est Late Marjorie Gerow, C/o Salomon Smith Barney, 55 Broad Street, Red Bank NJ 07701 USA	99.49	”	”
Mr Andrew Goddard, 32 Red Rock Road, Brandford, USA	613.63	”	03/07/00
Mr Andrew Goddard, 32 Red Rock Road, Brandford, USA	522.97	”	06/12/00
Ms Sheila Ann Hanks, C/o BHP Minerals, 550 California Street, San Francisco CA 94104 USA	94.21	”	”
Ms Sheila Ann Hanks, C/o BHP Minerals, 550 California Street, San Francisco CA 94104 USA	110.54	”	03/07/00
Mr David Kiyoshi Harada, 98-1761b Kaahumanu Street, Honolulu HI 96701 USA	51.55	”	06/12/00
Est Late Mike Hassey, C/o Mrs Lynn Powell, 6908 Arrowwood Drive, Riverbank CA 95367 USA	99.49	”	”
Mr Peter Joffre Hayes, C/o DMB & B, Suite 803, Caso Building, 1225 Ponce De Leon Avenue, Santurce PR 00907 USA	89.95	”	06/12/00
Mr Peter Joffre Hayes, C/o DMB & B, Suite 803, Caso Building, 1225 Ponce De Leon Avenue, Santurce PR 00907 USA	106.54	”	03/07/00
Est Late Patrick A. Hill, C/o Declan Hill, 599 Yonge St, Suite 104 Toronto Ontario M4Y 1Z6 Canada	64.18	”	06/12/00
Est Late Patrick A. Hill, C/o Declan Hill, 599 Yonge St, Suite 104 Toronto Ontario M4Y 1Z6 Canada	79.83	”	03/07/00
Mr Paul Roland Hollingsworth, C/o Sungard Future Systems, 1 S Wacker, Suite 400, Chicago IL 60606 USA	70.75	”	06/12/00
Mr Paul Roland Hollingsworth, C/o Sungard Future Systems, 1 S Wacker, Suite 400, Chicago IL 60606 USA	83.02	”	03/07/00
Est Late James Thomas Hornby, C/o John S. Keenlyside & Co, 622-470 Granville Street, Vancouver BC V6C 1V5 Canada	234.54	”	”
Mr Lorenzo Huarca, BHP Tintaya S A, 1360 Post Oak Boulevard, 500 Houston TX 77056 USA	64.44	”	06/12/00
Mrs Daphne Huntington, 1835 Outpost Drive, Hollywood, California 90068 USA	122.30	”	”
Mrs Daphne Huntington, 1835 Outpost Drive, Hollywood, California 90068 USA	152.52	”	03/07/00
Mr Peter Ralph Isler, 25 Elder Avenue, Bergenfield NJ 07621 USA	60.49	”	”
Mr Marcelino Alejandr Jahuirra, Av San Martin 301 Urb Vallecito, Arequipa Peru	64.44	”	06/12/00
Mr Timoteo Kali, BHP Tintaya SA, 1360 Post Oak Boulevard, 500 Houston TX 77056 USA	64.44	”	”
Mr Alfredo Leandro Kana, BHP Tintaya SA, 1360 Post Oak Boulevard, 500 Houston TX 77056 USA	64.44	”	”
Mrs Louise Maree Kelsey, 8 Segada Street, Rancho Santa Margarita, S Cal 92688 USA	97.53	”	03/07/00
Mrs Louise Maree Kelsey, 8 Segada Street, Rancho Santa Margarita, S Cal 92688 USA	83.12	”	06/12/00
Mr Paul V. Kirby, 26 Captains Drive, Westerly, Rhode Island 02891 USA	91.24	”	”

2532 G 38 19 September 2002

Victoria Government Gazette

Klemann Corporation, C/o Morgan Guaranty Trust Company of New York, Attention Mark C. Apprahamian, Level 6/23 Wall Street, New York NY 10015 USA	202.93	”	03/07/00
Mr Robert Michael Korodan, 95-310 Ho'okowa Place Miliani HI 96789 USA	60.49	”	”
Mr Jacob Hime Kress, PO Box 14258, Gainesville FLA 32604 USA	484.53	”	03/07/00
Mr Jacob Hime Kress, PO Box 14258, Gainesville FLA 32604 USA	406.99	”	06/12/00
Dr John Edgar Larson, BHP Billiton/Santiago, 1360 Post Oak Boulevard, Suite 500, Houston TX 77056-3020 USA	167.54	”	”
Mr Luis Lazarte, Av San Martin, 301 Urb Vallecito, Arequipa, Peru	64.44	”	”
Mrs Colina Moira Lennon, C/o R. M. Lennon, 100 Edgemont Road, Katonah, New York 10536 USA	60.44	”	”
Mr George Ross Martin, 4519 Leo Court, Ne Albuquerque NM 87109 USA	60.49	”	03/07/00
Mrs Meryl McGill, 19 Rains Way, Houston, Texas 77007 USA	1,543.28	”	06/12/00
Dr Kathleen Alison McGuire, 4076 17th Street, 302 San Francisco CA 94114 USA	148.49	”	03/07/00
Mr Gary Neal McKee, 2765 Bonanza Street, Rocklin CA 95677 USA	61.24	”	”
Mr Gary Neal McKee, 2765 Bonanza Street, Rocklin CA 95677 USA	52.19	”	06/12/00
Mrs Sharon P. Middleton, Mountain Hollow Farm, Route 1, Box 90, Greenwood VA 22943 USA	99.49	”	”
Mrs Sharon P. Middleton, Mountain Hollow Farm, Route 1, Box 90, Greenwood VA 22943 USA	116.74	”	03/07/00
Mr Daniel Joseph Mitchell & Mr Daniel Aloysius Sullivan, C/o Thomson & Mckinnon Securities, One New York Plaza, New York 10005 USA	79.84	”	”
Mr Daniel Joseph Mitchell & Mr Daniel Aloysius Sullivan, C/o Thomson & Mckinnon Securities, One New York Plaza, New York 10005 USA	68.05	”	06/12/00
Mr Kenneth W. Moorhead & Mrs Henrietta M. Moorhead, 5627 Yerba Anita Drive, San Diego CA 92115 USA	404.02	”	”
Miss Joan Houston Mowbray, 12A Reeves Place, St Johns, Newfoundland A1B 2J4 Canada	175.86	”	03/07/00
Miss Joan Houston Mowbray, 12A Reeves Place, St Johns, Newfoundland A1B 2J4 Canada	149.88	”	06/12/00
Mrs Tui Aroha Nourtier, C/o Sutton, Apt 3A, 313 East, 78th Street, New York NY10021 USA	190.48	”	”
Mrs Tui Aroha Nourtier, C/o Sutton, Apt 3A, 313 East, 78th Street, New York NY10021 USA	223.50	”	03/07/00
Mrs Penelope L. Oppenheimer, 8336 Barnsley Avenue, Los Angeles CA 90045 USA	218.31	”	06/12/00
Overseas Nominee Company Inc., C/o First National City Bank, 20 Exchange Place, New York NY 10005 USA	114.77	”	03/07/00

Painweb Nominees Inc., 25 Broad Street, New York NY 10004 USA	475.73	”	”
Painweb Nominees Inc., 25 Broad Street, New York NY 10004 USA	405.44	”	06/12/00
Miss Elizabeth Anne Patterson, 1260 Docteur Penfield, Montreal H3G 1B6 Quebec, Canada	138.54	”	”
Miss Elizabeth Anne Patterson, 1260 Docteur Penfield, Montreal H3G 1B6 Quebec, Canada	168.85	”	03/07/00
Mr John K. Patterson & Mrs Valona L. Patterson, 799 Yellowstone Drive, Apartment 179, Vacaville CA 95687 USA	128.42	”	03/07/00
Mr John K. Patterson & Mrs Valona L. Patterson, 799 Yellowstone Drive, Apartment 179, Vacaville CA 95687 USA	102.33	”	06/12/00
Mrs Elsie Grass Penniman, 310 South Road, Farmington, Connecticut 06032 USA	69.85	”	”
Mrs Elsie Grass Penniman, 310 South Road, Farmington, Connecticut 06032 USA	81.96	”	03/07/00
Mrs Elizabeth Brown Phelan, 250 Sherman Avenue, Hawthorne, New York 10532 USA	99.49	”	06/12/00
Mrs Elizabeth Brown Phelan, 250 Sherman Avenue, Hawthorne, New York 10532 USA	116.74	”	03/07/00
Est Late Walter Rice, C/o Trust Company of Virginia, 9030 Stony Point Parkway, Suite 300, Richmond VA 23235 USA	141.76	”	06/12/00
Est Late Hillel Rivlin, C/o Mr Edward Frede Keane Tracers, One Tower Bridge, 100 Front Street, West Conshocken PA 19428-2886 USA	876.45	”	03/07/00
Est Late Hillel Rivlin, C/o Mr Edward Frede Keane Tracers, One Tower Bridge, 100 Front Street, West Conshocken PA 19428-2886 USA	746.96	”	06/12/00
Mr Louis Ferdinand Rothschild, 55 Water Street, New York 10041 USA	1,140.77	”	03/07/00
Mr Louis Ferdinand Rothschild, 55 Water Street, New York 10041 USA	972.23	”	06/12/00
Mr Peter Russell, Box 354 (8803), 12625 Frederick Street, Moreno Valley, California 92553 USA	191.14	”	03/07/00
Mr Peter Russell, Box 354 (8803), 12625 Frederick Street, Moreno Valley, California 92553 USA	158.26	”	06/12/00
Est Late Elizabeth Sadlon, C/o Advest, PO Box 733, 49 Route 202 Far Hills NJ 07931 USA	200.01	”	”
Mr Carlos Saico, Av San Martin, 301 Urb Vallecito, Arequipa, Peru	64.44	”	”
Mrs Santa Gaspari & Mr Donald Gaspari, Unit 603 1111 Bering Drive, Houston TX 77057 USA	137.16	”	03/07/00
Mrs Santa Gaspari & Mr Donald Gaspari, Unit 603 1111 Bering Drive, Houston TX 77057 USA	109.54	”	06/12/00
Saxon & Co, Airport Business Center, International Court 2, 200 Stevens Drive, Lester PA 19113 USA	244.52	”	03/07/00
Mr Mark Jay Schulthes, 881 North, 3000 West Vernal, Utah 84078 USA	535.39	”	”
Mr Mark Jay Schulthes, 881 North, 3000 West Vernal, Utah 84078 USA	454.54	”	06/12/00

2534 G 38 19 September 2002

Victoria Government Gazette

Mr Bernard Roy Seeff, 4370 Colfax Avenue, 3 Studio City, CA 91604 USA	731.36	”	03/07/00
Mr Bernard Roy Seeff, 4370 Colfax Avenue, 3 Studio City, CA 91604 USA	617.83	”	06/12/00
Est Late Ralph Shuster, C/o Mathew Shuster, PO Box 2762, Providence RI 02907 USA	451.98	”	03/07/00
Est Late Ralph Shuster, C/o Mathew Shuster, PO Box 2762, Providence RI 02907 USA	385.21	”	06/12/00
Mr David Alexander Simpson, C/- P. E. Mulcahy Dicksons Limited, GPO Box 2613, Sydney, NSW	145.76	”	”
Mrs Ruth Smith, PO Box 79093, Houston TX 77279-9093 USA	76.90	”	03/07/00
Est Late George R. Spence, 15316 Pine Orchard Drive, 2A Silver Spring, Maryland 20906 USA	116.74	”	”
Est Late George R. Spence, 15316 Pine Orchard Drive, 2A Silver Spring, Maryland 20906 USA	99.49	”	06/12/00
Mr John Digby Graham Steacy, 280 Summit Avenue, Ottawa, Ontario K1H 5Z8 Canada	53.23	”	”
Ms Virginia Louise Swinnen, 1285 Candlewood Drive, Downers Grove IL 60515 USA	1,548.00	”	03/07/00
Ms Virginia Louise Swinnen, 1285 Candlewood Drive, Downers Grove IL 60515 USA	1,319.29	”	06/12/00
Mr Gregory Kenneth Thompson, C/o BHP Utah Minerals Intl, 550 California Street, San Francisco CA 94104 USA	65.73	”	”
Mr Gregory Kenneth Thompson, C/o BHP Utah Minerals Intl, 550 California Street, San Francisco CA 94104 USA	77.12	”	03/07/00
Mr Laurence Michael Thomson, 1131 Duchess Avenue, West Vancouver BV V7T 1HL Canada	78.61	”	06/12/00
Torbay Company, The Toronto Dominion Bank, Toronto Securities Centre, 55 King Street West & Bay Street, Toronto, Ontario M5K 1A2 Canada	561.64	”	”
Mr Ronald Clare Trussler, 536 Gilmour Street, Peterborough, Ontario K9H 2K2 Canada	349.25	”	”
Mr Hugh L. Turk Jr, 489 Summit Circle, Fredericksburg TX 78624 USA	659.87	”	03/07/00
Mr Hugh L. Turk Jr, 489 Summit Circle, Fredericksburg TX 78624 USA	562.28	”	06/12/00
United States Trust Co of New York, The Assistant Secretary, 45 Wall St, New York NY 10005 USA	491.60	”	03/07/00
United States Trust Co of New York, The Assistant Secretary, 45 Wall St, New York NY 10005 USA	418.97	”	06/12/00
Mr Robin Ellis Von Knorring, 11423 Hollow Timber Court, Reston VA 20194-1980 USA	93.56	”	”
Mr John Alexander Walter, 7 Piers Avenue, Halifax, Nova Scotia B3N IZ2 Canada	71.22	”	03/07/00
Mr John Alexander Walter, 7 Piers Avenue, Halifax, Nova Scotia B3N IZ2 Canada	60.70	”	06/12/00
Miss Colette Helene Warren, C/o Mrs C. H. Filippini, 543 E. Greening Road, Westville, Indiana 46391 USA	58.89	”	03/07/00
Wertma Nominees Incorporated, C/o Wertheim & Co Inc, 200 Park Avenue, New York NY 10017 USA	85.44	”	”

*Victoria Government Gazette**G 38 19 September 2002 2535*

Wertma Nominees Incorporated, C/o Wertheim & Co Inc, 200 Park Avenue, New York NY 10017 USA	72.81	”	06/12/00
Mr Stanley Boyd Williams, 697 Carlow Court, El Cajon, California 92020 USA	99.49	”	”

02166

CONTACT: BHP Billiton Share Department. Phone: 1300 656 780.

Unclaimed Moneys Act 1962

Register of Unclaimed Moneys held by the —

<i>Name of Owner on Books and Last Known Address</i>	<i>Total Amount Due to Owner</i>	<i>Description Of Unclaimed Money</i>	<i>Date when Amount first became Payable</i>
GADENS LAWYERS			
	\$		
Johnny Nob Nor, 105 Ballarto Road, Carrum Downs	22,191.98	Cheque	17/08/01

02255

CONTACT: GILLIAN DEVINE, PHONE: (03) 9612 8295.

PROCLAMATIONS

ACTS OF PARLIAMENT

Proclamation

I, John Landy, Governor of Victoria, declare that I have today assented in Her Majesty's name to the following Bill:

No. 41/2002 **Guardianship and Administration (Amendment) Act 2002**

Given under my hand and the seal of Victoria at Melbourne on 17 September 2002.

(L.S.) JOHN LANDY
Governor
By His Excellency's Command

STEVE BRACKS
Premier

-
- No. 41/2002 (1) This Act comes into operation on a day or days to be proclaimed.
- (2) If a provision of this Act does not come into operation before 1 January 2003, it comes into operation on that day.
-

**GOVERNMENT AND OUTER BUDGET SECTOR AGENCIES
NOTICES**

MONASH CITY COUNCIL

Road Discontinuance

At its meeting on 19 March, 2002, and acting under Clause 3 of Schedule 10 to the **Local Government Act 1989**, Monash City Council ("Council"):

1. formed the opinion that part of the unmade road abutting 5 Fleet Street, Mount Waverley [and being the land shown on the plan below ("the road")] is not reasonably required as a road for public use; and
2. resolved to discontinue the road and retain the land from the road.

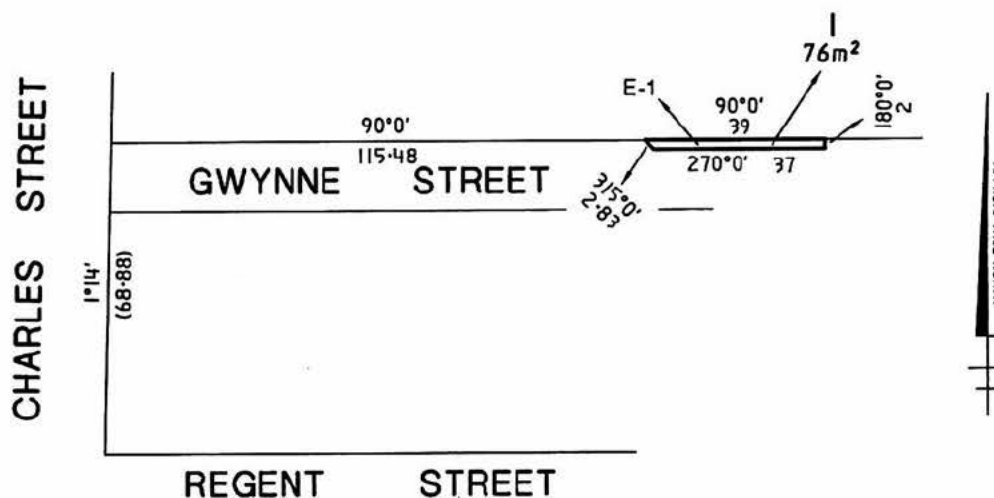

1. that closure of the road is subject to any right, title, power, authority or interest held by Yarra Valley Water in the land in connection with any drains or pipes laid or erected in on or over such land for the purposes of drainage and sewerage under the control of that authority in or near the road;
2. that closure of the road is subject to the right, title, power, authority or interest held by Monash City Council in the land in connection with connection with any drains or pipes land or erected in on or over such land for the purposes of drainage and sewerage under the control of that authority in or near the road.

DAVID CONRAN
Chief Executive Officer

MONASH CITY COUNCIL

Road Discontinuance

At its meeting on 1 May, 2001 and acting under Clause 3 of Schedule 10 to the **Local Government Act 1989**, Monash City Council ("Council"):

1. formed the opinion that the road abutting 54–78 High Street Road; 2–6 Shaw Street; 13 May Park Avenue and 1–5 Queens Parade Ashwood [and being the land shown on the plan below ("the road")] is not reasonably required as a road for public use; and

2538 G 38 19 September 2002

Victoria Government Gazette

- resolved to discontinue the road and either retain the land from the road or sell the land from the road by private treaty to abutting property owners.

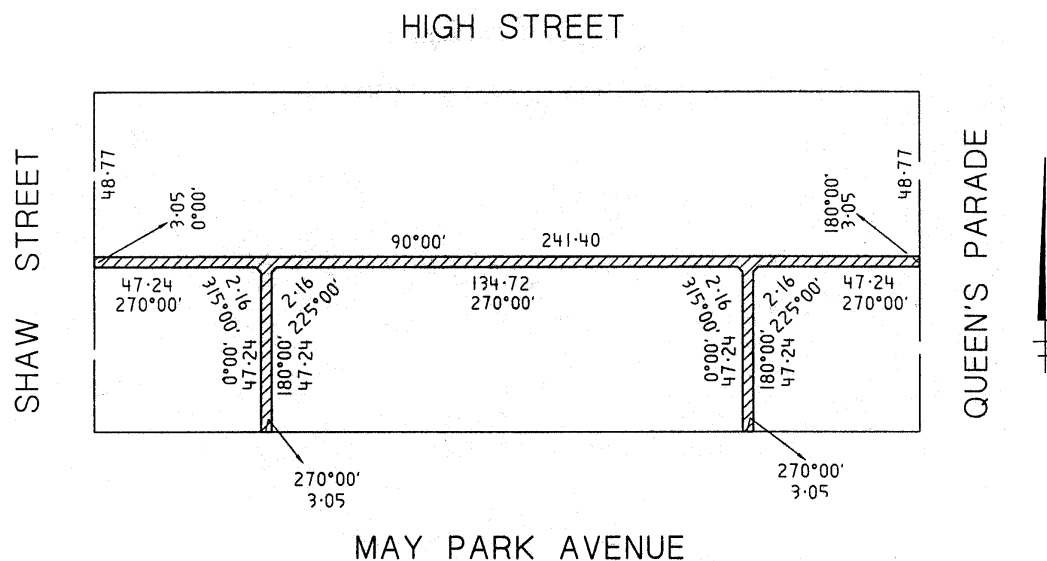

- that closure of the road is subject to any right, title, power, authority or interest held by Yarra Valley Water in the land in connection with any drains or pipes laid or erected in on or over such land for the purposes of drainage and sewerage under the control of that authority in or near the road;
- that closure of the road is subject to the right, title, power, authority or interest held by Monash City Council in the land in connection with connection with any drains or pipes land or erected in, on or over such land for the purposes of drainage and sewerage under the control of that authority in or near the road.

DAVID CONRAN
Chief Executive Officer

SWAN HILL RURAL CITY COUNCIL

Road Discontinuance

Discontinuance of Part of Pritchard Street between High Street and Stradbroke Avenue
Township of Swan Hill

Pursuant to Section 206 and Schedule 10 Clause 3 of the **Local Government Act 1989** the Swan Hill Rural City Council at its ordinary meeting held on Tuesday 13 August 2002 formed the opinion that the road described above and as shown hatched on the plan below, is not reasonably required as a road for public use. Council has resolved to discontinue the road and transfer the land from the road to the adjacent Show Yards and Public Recreation Reserve, subject to any right, power or interest held by Lower Murray Water, Council, Gas & Fuel Corporation and Telecom in the road in connection with any sewers, drains, pipes, wires or cables under the control of those authorities in or near the road.

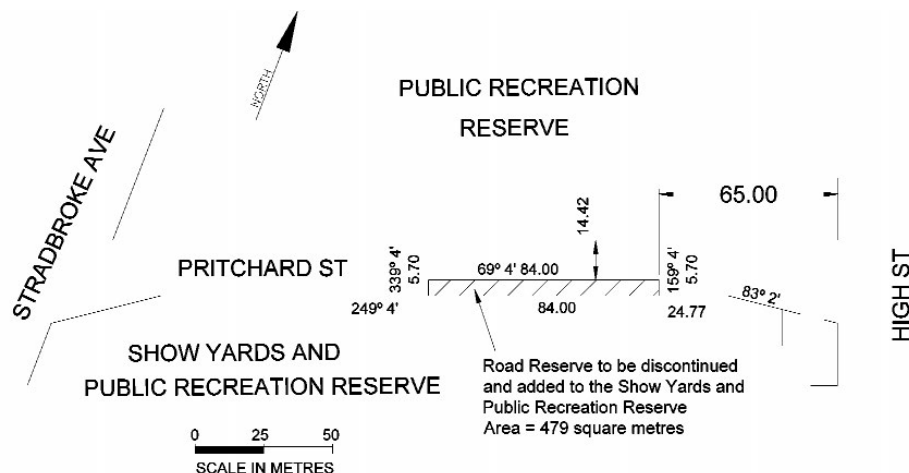

JOHN WEBB
Chief Executive Officer

COLAC OTWAY SHIRE

Partial Road Discontinuance

Pursuant to Schedule 10, Clause 3 of the **Local Government Act 1989** the Colac–Otway Shire Council, at its Ordinary Meeting held on 28 August 2002, formed the opinion that a portion of the road being part of Calvert Street, Colac and shown on the plan below, is not reasonably required as a road for public use and resolved to discontinue that portion of the road so that the appropriate authorities may consider the sale of the area to the abutting property owner.

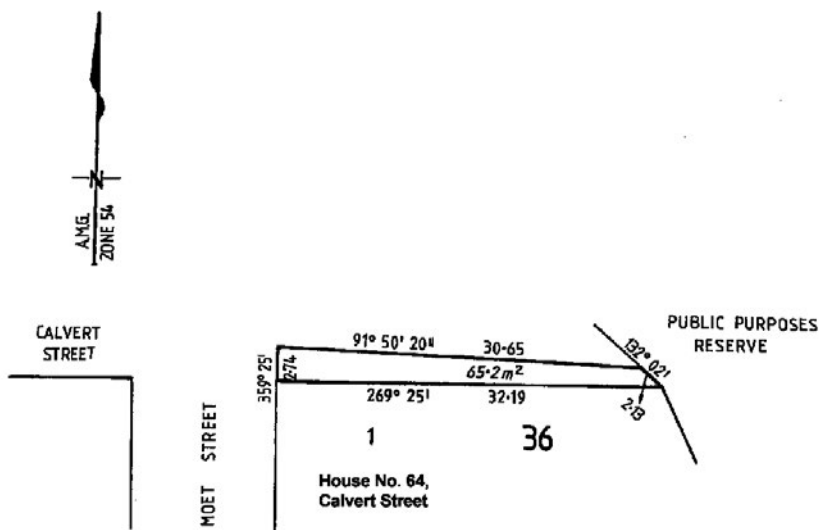

MERV HAIR
Acting Chief Executive Officer

2540 G 38 19 September 2002

Victoria Government Gazette

GREATER GEELONG CITY COUNCIL

Road Discontinuance

On 15 August 2002 and acting under clause 3 of schedule 10 to the **Local Government Act 1989**, Greater Geelong City Council resolved to discontinue the road shown hatched on the plan below.

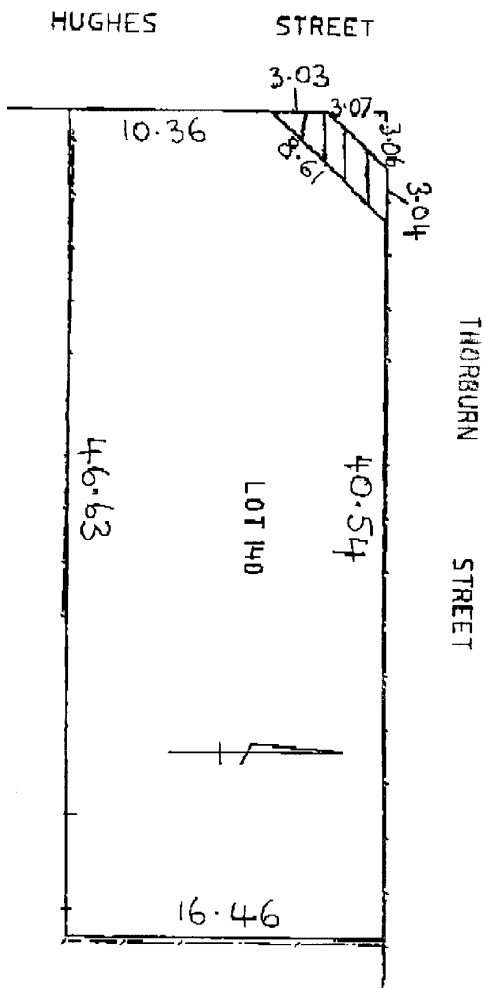

resolved to discontinue the road and to sell the land from the road by private treaty to the abutting property owner.

The section of road shown cross-hatched is to be sold subject to the right, power or interest held by City West Water Limited in the road in connection with any sewers, drains or pipes under the control of that authority in or near the road.

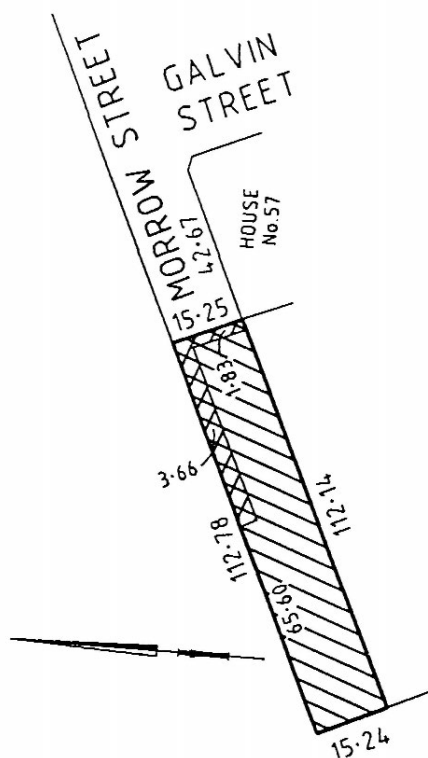

KENNETH McNAMARA
Chief Executive Officer



MORNINGTON PENINSULA
Shire Council

HOBSONS BAY CITY COUNCIL

Road Discontinuance

Pursuant to section 206 and schedule 10, clause 3 of the **Local Government Act 1989**, the Hobsons Bay City Council at its ordinary meeting held on 10 September 2002, formed the opinion that the western part of Morrow Street, Altona, shown by both hatching and cross-hatching on the plan below, is not reasonably required as a road for public use and

MAKING OF LOCAL LAW

Amendments to Local Law No. 6
Streets and Roads

Notice is hereby given in accordance with Section 119(3) of the **Local Government Act 1989** that the Council of the Mornington Peninsula Shire resolved at its Meeting on 16 September 2002 to amend Part 11 – Movable Advertising Signs of Local Law No. 6 – Streets and Roads.

The purpose of this amendment is to control and regulate movable signs on any land and in any public place.

The general purport of this amendment is as follows:

- prohibits the placement of any Temporary Community Event and Information Signage in any public place or on any land without first obtaining a permit from Council;
- the controls and procedures for the granting of permits and the management of the erection of Temporary Community Event and Information Signage, Movable Advertising Signage and Real Estate Signage within the Municipal District are contained within Council Policy No. 3.7 – Comprehensive Signage Policy;
- reduces the number of additional movable advertising signs that may be placed at nearby intersections on the day of auction or open house from three to one. Additionally there will be a requirement that these signs must specify the date and time of the auction or open house.

The amendments to the Local Law come into operation on 20 September 2002.

A copy of the Local Law may be inspected at Council's Customer Service Centres and Branch Libraries at Rosebud, Mornington, Hastings and Somerville during office hours.

(Dr) MICHAEL KENNEDY
Chief Executive Officer



PROPOSED AMENDMENT TO LOCAL
LAW No. 3

Roads, Streets and Public Places

The Shire of Campaspe at its Council Meeting held on 10 September 2002 resolved to make amendments to Local Law No. 3 pursuant to provisions of the **Local Government Act 1989**.

Council resolved to give notice of its intent to amend Local Law No. 3 by adding the following clauses:

Clause 3.18 Behaviour

A person by their actions or manner or language and within the view or hearing of any person being or passing or therein or thereon must not behave in a municipal place in such circumstances as to –

- a) interfere with another person's reasonable use and enjoyment of that municipal place; or
- b) endanger or be likely to endanger health, life or property.

Clause 3.19 Council Signs

A person must comply with any sign erected in a municipal place by Council.

Amend Clause 5.3(b) as follows:

The penalty fixed for infringement notices is two (2) penalty units.

The purpose of this Local Law is to:

- to provide for the peace, order, well being and safety of people in the municipal district;
- to provide for the administration of Council's powers and functions;
- to prohibit, regulate and control activities, events, practices of behaviour in places, so that no detriment is caused to the amenity of the neighbourhood nor nuisance to a person, nor detrimental effect to a person's property.

Any person may inspect a copy of the proposed amendments to the Roads, Streets and Public Places Local Law at the following Customer Services Centres: Shire Headquarters, corner Hare & Heygarth Streets, Echuca, Vic. 3564; Rochester Service Centre, 43–45 Mackay Street, Rochester, Vic. 3561; Kyabram Service Centre, Lake Road, Kyabram, Vic. 3620; Tongala Service Centre, Managan Street, Tongala, Vic. 3621 and Ruthworth Service Centre, High Street, Rushworth, Vic. 3612.

Any person affected by the proposed local law may make a written submission to Council. To be considered, a submission must reach Council within 21 days of the publication of this notice.

Submissions will be considered in accordance with Section 223 of the **Local Government Act 1989**. Any person who makes a submission may request in writing that he or she be heard in person or by a person acting on his or her behalf.

2542 G 38 19 September 2002

Victoria Government Gazette

All submissions must be addressed to: The Chief Executive Officer, Campaspe Shire Council Headquarters, PO Box 35, corner Hare & Heygarth Streets, Echuca 3564.

PHIL PEARCE
Chief Executive Officer

Planning and Environment Act 1987
GREATER GEELONG PLANNING SCHEME
Notice of Amendment
Amendment C55

The City of Greater Geelong has prepared Amendment C55 to the Greater Geelong Planning Scheme which will commence public exhibition on 19 September 2002 and close on 21 October 2002.

The Amendment proposes to amend the Greater Geelong Planning Scheme by applying a Public Acquisition Overlay 3 (PAO3) to land in the vicinity of The Esplanade, Seabreeze Parade, and Seabeach Parade, North Shore. The purpose of the PAO3 is to facilitate the acquisition of land for the construction of a new Bayside Main Road by VicRoads.

The Amendment documents can be viewed on Council's website
www.geelongcity.com.au/comment or
www.doi.vic.gov.au/planning_scheme_amendments online.

The Amendment documents can also be inspected at: City of Greater Geelong, Ground Floor, 131 Myers Street, Geelong 3220; Department of Infrastructure, Office of Planning, 180 Fyans Street, South Geelong 3219 and Department of Infrastructure, Level 3 Plaza, Nauru House, 80 Collins Street, Melbourne 3000.

Submissions about the Amendment can be made via Council's website
www.geelongcity.com.au/comment or in writing addressed to: Strategic Planning Coordinator, City Planning and Special Projects Unit, City of Greater Geelong, PO Box 104, Geelong 3220, by Monday 21 October 2002.

IAN McCARTNEY
Co-Ordinator Strategic Planning

Planning and Environment Act 1987
MARIBYRNONG PLANNING SCHEME
Notice of Amendment
Amendment C36

The Maribyrnong City Council, as Planning Authority, has prepared Amendment C36 to Maps 8, 8EAO of the Maribyrnong Planning Scheme. Amendment C36 replaces an identical Amendment C3 on the subject land which recently lapsed.

The Amendment proposes to change the Maribyrnong Planning Scheme by rezoning land located at 51–61 Hopkins Street, Footscray from Business 3 Zone to Mixed Use Zone and introduces an Environmental Audit Overlay over the land.

The Amendment will require a map amendment to be carried out to Map Nos. 8 and 8EAO.

The Amendment is consistent with the relevant clauses of the State Planning Policy Framework, the Municipal Strategic Statement of the Maribyrnong Planning Scheme and Ministerial Direction No.1 – Potentially Contaminated Land.

A copy of the Amendment can be inspected, free of charge, during office hours, at: Reception Area, City of Maribyrnong Municipal Offices, corner Napier and Hyde Streets Footscray 3011 and Department of Infrastructure, Customer Service Centre, Upper Plaza (Level 3), Nauru House, 80 Collins Street, Melbourne 3000.

Submissions about the Amendment must be in writing and be sent to the following address by no later than Monday 21 October 2002: Co-ordinator Strategic Planning, Urban Planning Branch, Maribyrnong City Council, PO Box 58, Footscray, Victoria 3011.

Dated 17 September 2002

KAY RUNDLE
Chief Executive Officer

Planning and Environment Act 1987
SWAN HILL PLANNING SCHEME
Notice of Amendment
Amendment C9

The Swan Hill Rural City Council has prepared Amendment C9 to the Swan Hill Planning Scheme.

The Amendment affects a parcel of land known as Lot 1 on PS437857, Part Crown Allotment 63 & 64, Section A, Parish of Castle

Donnington, located on Back Boga Road, Castle Donnington, and as shown on the map accompanying this Amendment).

The Amendment proposes to change the planning scheme by:

- rezoning the subject land from Public Use – Local Government (PUZ6) to Rural (RUZ);
- the existing overlays (Airport Environs Overlay 1 and Design and Development Overlay 1 – Airport Environs – Restricted Building Heights) that apply to the subject site and surrounding land will be retained.

This Amendment is required to enable Swan Hill Rural City Council to dispose of the portion of unused aerodrome land to allow the land to be used for agricultural purposes.

The Amendment is available for inspection, free of charge, during office hours, at the following offices:- Swan Hill Rural City Council, 45 Splatt Street, Swan Hill; Department of Infrastructure, Regional Office, Lansell Street, Bendigo and Department of Infrastructure, Customer Service Centre, Nauru House, 80 Collins Street, Melbourne.

Any person may make a submission on the Amendment. Submissions should clearly state all of the grounds on which the Amendment is supported or opposed. Any submission lodged is a public document.

Submissions regarding the Amendment must be sent to: Mr Ken Fulford, Planning Officer, Swan Hill Rural City Council, 45 Splatt Street, Swan Hill 3585.

Submissions must be received by Tuesday 22 October 2002.

Planning and Environment Act 1987

WEST WIMMERA PLANNING SCHEME

Notice of Amendment

Amendment C4

West Wimmera Shire Council has prepared Amendment C4 to the West Wimmera Planning Scheme.

The Amendment applies to one property, known as part of Crown Allotment 3, Township of Lillimur North, adjacent to Lillimur Railway Station. It introduces an Industrial 1 Zone with a Schedule to the West Wimmera Planning Scheme, and rezones this property from Rural Zone to Industrial 1 Zone.

Grain Corp Ltd have requested the rezoning of this land (approx. 14 ha) in order to subdivide and purchase this parcel of land from the

adjacent farmland owner. This could not take place under the present zoning because the minimum size of lot in a subdivision in the rural zone is 80 ha. The land will be used for upgrading of grain receival and storage facilities.

A copy of the Amendment can be inspected, free of charge, during office hours, at: West Wimmera Shire Council, 49 Elizabeth Street, Edenhope 3318; Department of Infrastructure, Western Regional Office, 88 Learmonth Road, Wendouree 3355; West Wimmera Shire Council, 25 Baker Street, Kaniva 3419 and Department of Infrastructure, Planning Information Centre, Upper Plaza, Nauru House, 80 Collins Street, Melbourne 3000.

Submissions about the Amendment must be sent to: The Chief Executive Officer, West Wimmera Shire Council, PO Box 201, Edenhope 3318 by 19 October 2002.

REX MOONEY
Chief Executive Officer
West Wimmera Shire Council

Planning and Environment Act 1987

CASEY PLANNING SCHEME

Notice of the Preparation of an Amendment

Amendment C39

The land affected by the Amendment is the land within the “Non-urban South” area, including Stage 2 of the Botanic Ridge Development Plan. It is defined as the area bounded by Ballarto Road to the north, South Gippsland Highway to the east, Baxter–Tooradin Road to the south and Dandenong–Hastings Road (Western Port Highway) to the west, but excluding the township of Pearcedale, as shown on the map on the reverse side of this notice.

The Amendment proposes to:

1. implement Stage 2 of the Botanic Ridge Development Plan (BRDP) by:
 - applying a Development Plan Overlay (DPO3) to the BRDP area;
 - rezoning land within the BRDP area for residential purposes;
 - applying a Development Contributions Plan (DCPO11) to part of the BRDP area;
 - removing part of the existing Environmental Significance Overlay (ESO3) affecting the BRDP area;

2544 G 38 19 September 2002

Victoria Government Gazette

- applying a Public Acquisition Overlay (PAO3) to provide for the realignment of Craig Road; and,
 - introducing a new public open space requirement for part of the BRDP area.
2. introduce the 'The Farm (Non-urban South) Policy' to the Local Planning Policy Framework;
 3. link the 'The Farm (Non-urban South) Policy' to the Municipal Strategic Statement;
 4. make associated adjustments to Clauses 21 and 22.

The person who requested the Amendment is The City of Casey.

You may inspect the Amendment; any documents that support the Amendment; and the explanatory report about the Amendment at the office of the planning authority: Casey City Council Municipal Offices, Princes Highway, Narre Warren; Casey City Council, Customer Service Centre, Cranbourne Park Shopping Centre, (opposite Post Office), Cranbourne and at Department of Infrastructure, Planning Information Centre, Upper Plaza, Nauru House, 80 Collins Street, Melbourne.

This can be done during office hours and is free of charge.

Any person who may be affected by the Amendment may make a submission to the planning authority.

The closing date for submissions is 21 October 2002. A submission must be sent to: Manager Planning, Casey City Council Municipal Offices, PO Box 1000, Narre Warren 3805.

Should you have any queries about this Amendment, please contact the City of Casey on (9705 5200).

Dated 16 September 2002

Signature for the planning authority
JACQUI HOUGUET
Manager Planning

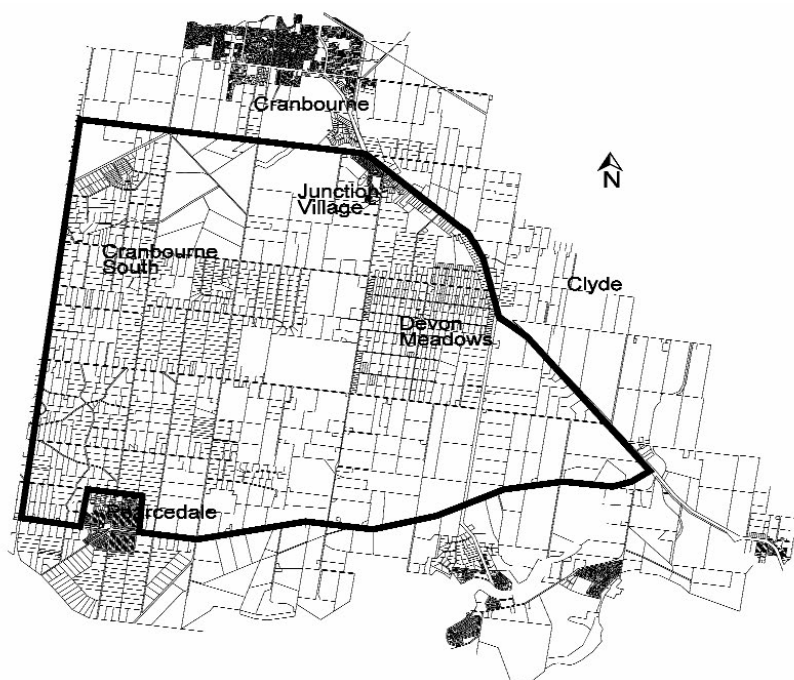

Area to which Amendment applies

Creditors, next-of-kin and others having claims against the estate of any of the undermentioned deceased persons are required to send particulars of their claims to State Trustees Limited, ACN 064 593 148, 168 Exhibition Street, Melbourne, Victoria 3000, the personal representative, on or before 20 November 2002 after which date State Trustees Limited may convey or distribute the assets having regard only to the claims of which State Trustees Limited then has notice.

ALSOPE, Isobel Eleanor, late of Bodalla Aged Care Services, 32 Walpole Street, Kew, pensioner, who died 30 September 2001.

AYRES, Mervyn John, late of Edgarly Home, 85 Jackson Street, Casterton, pensioner, who died 24 June 2002.

BUTHCHER, Veronica May, late of 34 Wingate Avenue, Ascot Vale, pensioner, who died 21 April 2002.

CLARK, Florence Alice, late of 162 Yarra Road, Croydon North, retired, who died 9 August 2002.

COAKLEY, Brian, late of 29 Knight Drive, Glen Waverley, retired, who died 30 May 2002.

ELLIOTT, Edith Phyllis, late of Gracedale Private Nursing Home, 205 Warrandyte Road, Ringwood North, pensioner, who died 12 August 2002.

FLOWER, Thomas John, late of Summer House, 128 Fitzroy Street, Fitzroy, who died 25 July 2002.

JEPSON Reginald Raymond, late of 24 Tennyson Street, Highett, retired, who died 5 July 2002.

MILLER, Feliks, formerly of 11 Millewa Avenue, Chadstone, late of Oakmoor Nursing Home, 352 Warrigal Road, Oakleigh South, pensioner, who died 5 May 2002.

OSTERBURG, Elisabeth Katharina, late of 18 Young Street, St Kilda East, pensioner, who died 28 July 2002.

PUTTOCK, Grace, late of 12 Anarth Street, Bentleigh East, pensioner, who died 2 July 2002.

ROOKE, Margaret, late of Unit 3/6 Woorarra Avenue, Doncaster East, home duties, who died 1 July 2002.

STEWART, Andrew, late of Balwyn Manor, 23 Maleela Avenue, Balwyn, retired, who died 3 July 2002.

YOUNG, Margot Jean, late of Colanda Training Centre, 120 Forest Street, Colac, who died 4 April 2002.

ZANELLI, Eleanor, formerly of 29 Bona Vista Road, Bayswater, late of Amaroo Gardens, 811 Burwood Highway, Ferntree Gully, who died 2 July 2002.

Dated at Melbourne, 5 September 2002

LAURIE TAYLOR
Manager, Estate Management
State Trustees Limited

EXEMPTION

Application No. A269/2002

The Victorian Civil and Administrative Tribunal has considered an application pursuant to Section 83 of the **Equal Opportunity Act 1995** by Gordon Institute of Tafe for exemption from Sections 13, 37, 42, 100 and 195 of that Act. The application for exemption is to enable the applicant to advertise for, employ and provide educational services to a Koori trainee or trainees at the Institute.

Upon reading the material submitted in support of the application and upon hearing submissions from John Van Cleef and for the Reasons for Decision given by the Tribunal on 12 September 2002, the Tribunal is satisfied that it is appropriate to grant an exemption from Sections 13, 37, 42, 100 and 195 of the Act to advertise for, employ and provide educational services to a Koori trainee or trainees at the Institute.

The Tribunal hereby grants an exemption to the applicant from the operation of Sections 13, 37, 42, 100 and 195 of the **Equal Opportunity Act 1995** to enable the applicant to advertise for, employ and provide educational services to a Koori trainee or trainees at the Institute.

This exemption is to remain in force from the day on which notice of the exemption is published in the Government Gazette until 18 September 2005.

Dated 12 September 2002

Ms CATE McKENZIE
Deputy President

EXEMPTION

Application No. A274/2002

The Victorian Civil and Administrative Tribunal has considered an application pursuant to Section 83 of the **Equal Opportunity Act 1995** by Eastern Access Community Health Inc

2546 G 38 19 September 2002

Victoria Government Gazette

for exemption from Sections 13, 100 and 195 of that Act. The application for exemption is to enable the applicant in the process of selecting a person for employment as a liaison and support worker to give preference to applicants who are indigenous people and to state that it will give preference to those applicants in the advertisements for that position.

Upon reading the material submitted in support of the application and upon hearing submissions from Mr B. Durkin and Ms J. Bramwell and for the Reasons for Decision given by the Tribunal on 13 September 2002, the Tribunal is satisfied that it is appropriate to grant an exemption from Sections 13, 100 and 195 of the Act to enable the applicant in the process of selecting a person for employment as a liaison and support worker to give preference to applicants who are indigenous people and to state that it will give preference to those applicants in the advertisements for that position.

The Tribunal hereby grants an exemption from the operation of Sections 13, 100 and 195 of the **Equal Opportunity Act 1995** to enable the applicant in the process of selecting a person for employment as a liaison and support worker to give preference to applicants who are indigenous people and to state that it will give preference to those applicants in the advertisements for that position.

This exemption is to remain in force from the day on which notice of the exemption is published in the Government Gazette until 18 September 2005.

Dated 13 September 2002

Ms CATE McKENZIE
Deputy President

EXEMPTION

Application No. A303 of 2002

The Victorian Civil and Administrative Tribunal has considered an application pursuant to Section 83 of the **Equal Opportunity Act 1995** (the Act), by Springvale Community Aid & Advice Bureau (the applicant). The application for exemption is to enable the applicant to advertise for and employ a female lead tenant between the age of eighteen and twenty-eight years.

Upon reading the material submitted in support of the application, the Tribunal is satisfied that it is appropriate to grant an exemption from Sections 13, 100 and 195 of the Act to enable the applicant to advertise for and employ a female lead tenant between the age of eighteen and twenty-eight years.

In granting this exemption the Tribunal noted:

- the applicant manages transitional housing properties one of which only houses female students between the age of 15 and 22 years who are homeless or at risk of becoming homeless, who come from culturally and linguistically diverse backgrounds;
- the lead tenant must be able to be a role model for the tenants and needs to be of a similar age to the tenants so that the tenants can identify with the lead tenant;
- it is inappropriate for cultural and religious reasons for males who are not family members to live in the property and a male cannot provide the same role model support as a female.

The Tribunal hereby grants an exemption to the applicant from the operation of Sections 13, 100 and 195 of the Act to enable the applicant to advertise for and employ a female lead tenant between the age of eighteen and twenty-eight years.

This exemption is to remain in force from the day on which notice of the exemption is published in the Government Gazette until 12 September 2005.

Dated 11 September 2002

Mrs A. COGHLAN
Deputy President

Department of Treasury and Finance

SALE OF CROWN LAND
BY PUBLIC AUCTION

Date of Auction: 5 October 2002.

Reference: Former Leonards Hill Primary School.

Address of Property: Off Ballan – Daylesford Road, Leonards Hill.

Crown Description: Crown Allotment 11T, Section 4A, Parish of Wombat.

Victoria Government Gazette

G 38 19 September 2002 2547

Terms of Sale: 10% Deposit, Balance 60 days.

Area: 4047 square metres.

Officer Co-ordinating Sale: Sarah Smith,
Department of Education & Training Property
Branch, Level 2, 2 Treasury Place, East
Melbourne 3002.

Selling Agent: Bartrop Real Estate, 50–54
Lydiard Street South, Ballarat 3350.

JOHN LENDERS MP
Minister for Finance

Department of Treasury and Finance

SALE OF CROWN LAND
BY PUBLIC AUCTION

Date of Auction: 5 October 2002.

Reference: Former Elaine Primary School.

Address of Property: Morrisons Road, Elaine.

Crown Description: Crown Allotment 5,
Section 9, Township of Elaine, Parish of
Borhoneyghurk.

Terms of Sale: 10% Deposit, Balance 60 days.

Area: 1.55 ha.

Officer Co-ordinating Sale: Sarah Smith,
Department of Education & Training Property
Branch, Level 2, 2 Treasury Place, East
Melbourne 3002.

Selling Agent: Bartrop Real Estate, 50–54
Lydiard Street South, Ballarat 3350.

JOHN LENDERS MP
Minister for Finance

Association Incorporations Act 1981

SUB-SECTION 36E(5)

Notice is hereby given that the incorporation
of the associations mentioned below are
cancelled in accordance with section 36E(5) of
the **Associations Incorporation Act 1981**:

Cardinia Community Adventure Playground
Inc., Consumer's Association of Victoria Inc.,
Cressy Uniting Church Tennis Club Inc., Driva
(Driving Instructors of Victoria Association)
Inc., Gembrook Progress Association Inc.,
History Institute of Victoria Inc., Knox Business
Interest Group Inc., Salisbury Falls Water Users
Inc., The Association of Friends of Lakewood
Nature Reserve Inc., The Plumbing Industry
Association of Victoria Inc., Wonthaggi Toy

Library Inc., Yallourn North Junior Basketball
Club Inc.

Dated 19 September 2002

PAUL HOPKINS
Deputy Registrar
of Incorporated Associations

Casino Control Act 1991

MINISTERIAL DIRECTION

I, John Pandazopoulos, MP, Minister for
Gaming, under section 62A(4) of the **Casino
Control Act 1991** ("the Act"), direct the casino
operator as follows:

1. A bet limit of \$10 applies—
 - (a) to gaming machine games played in the
casino on or after 1 January 2003, being
gaming machine games approved on or
after that day; and
 - (b) to all gaming machine games played in
the casino on or after 1 January 2008.
2. The bet limit in paragraph 1 does not apply
to a game played on a gaming machine
located in an area specified by the Victorian
Casino and Gaming Authority under section
62AB(4), 62AC(2) or 81AAB(2) of the
Act if—
 - (a) the gaming machine can only be played
with a bet limit above \$10 by means of a
card, Personal Identification Number
(PIN) or similar technology that requires
the player to nominate limits on time
and net loss before play can commence;
and
 - (b) the total number of gaming machines in
all areas specified by the Victorian
Casino and Gaming Authority under
section 62AB(4), 62AC(2) or 81AAB(2)
of the Act does not exceed 1000.

Dated 12 September 2002

JOHN PANDAZOPOULOS MP
Minister for Gaming

Electoral Act 2002

CHANGE TO REGISTER OF POLITICAL
PARTIES

In accordance with section 51 of the
Electoral Act 2002, I hereby give notice of the
following change to the Register of Political
Parties.

2548 G 38 19 September 2002

Victoria Government Gazette

Name of registered political party:
National Party of Australia–Victoria.

Name of new Registered Officer: Ms
Meredith Dickie.

Dated 19 September 2002

COLIN BARRY
Electoral Commissioner

Health Act 1958

HEALTH (INFECTIOUS DISEASES)

REGULATIONS 2001

REGULATION 17(2)(a)(vi)

Prescribed Places

I, Dr Melissa Morgan, A/Manager, Blood Borne Virus/Sexually Transmissible Infectious Program and delegate of the Secretary to the Department of Human Services for the purposes of regulation 17(2)(a)(vi) of the Health (Infectious Diseases) Regulations 2001 —

1. revoke the nomination, as published in Government Gazette G21 on 23 May 2002, of Monash Reproductive Pathology and Genetics Pty Ltd, Clayton, as a prescribed place for the purposes of section 130(2) of the **Health Act 1958**;
2. nominate Monash Reproductive Pathology and Genetics Pty Ltd, Epworth Hospital, Richmond, as a prescribed place for the purposes of section 130(2) of the **Health Act 1958**.

Dated 13 September 2002

Dr MELISSA MORGAN
Acting Manager
Blood Borne Virus/
Sexually Transmissible Infections
Delegate of the Secretary to the
Department of Human Services

Land Acquisition and Compensation Act 1986

FORM 7

S.21

Reg. 16

Notice of Acquisition

Compulsory Acquisition of Interest in Land

Darebin City Council declares that by this notice it acquires the following interest in the land described as the whole of Lot 3050 on Plan of Subdivision 8538, Parish of Keelbundora and being land described in Certificate of Title

Volume 7244, Folio 732 and known as Lot 3050 Mahoneys Road, Reservoir, Vic. 3073.

Interest Acquired: That of Barry Edward Humphrey and all other interests.

Published with the Authority of Darebin City Council.

A plan relating to this notice may be viewed without charge at the office of Property Services Department, VicRoads, 4th Floor, North Building, 60 Denmark Street, Kew during the hours 9.00 am to 4.00 pm.

Dated 19 September 2002

For and on behalf of
Darebin City Council
ADRIAN O'BRIEN,
Acting Manager
Property Services Department.
Acting as agent for
Darebin City Council

Land Acquisition and Compensation Act 1986

FORM 7

S.21

Reg. 16

Notice of Acquisition

Compulsory Acquisition of Interest in Land

Darebin City Council declares that by this notice it acquires the following interest in the land described as the whole of Lot 3052 on Plan of Subdivision 8538, Parish of Keelbundora and being land described in Certificate of Title Volume 8221, Folio 369 and known as Lot 3052 Shiers Street, Reservoir, Vic. 3073.

Interest Acquired: That of Frank & Catherine Camilleri and all other interests.

Published with the Authority of Darebin City Council.

A plan relating to this notice may be viewed without charge at the office of Property Services Department, VicRoads, 4th Floor, North Building, 60 Denmark Street, Kew during the hours 9.00 am to 4.00 pm.

Dated 19 September 2002

For and on behalf of
Darebin City Council
ADRIAN O'BRIEN,
Acting Manager
Property Services Department.
Acting as agent for
Darebin City Council

Land Acquisition and Compensation Act 1986

FORM 7

S.21

Reg. 16

Notice of Acquisition

Compulsory Acquisition of Interest in Land

Darebin City Council declares that by this notice it acquires the following interest in the land described as the whole of Lot 3053 on Plan of Subdivision 8538, Parish of Keelbundora and being land described in Certificate of Title Volume 8495, Folio 273 and known as Lot 3053 Shiers Street, Reservoir, Vic. 3073.

Interest Acquired: That of Paolo & Santina Guarino and all other interests.

Published with the Authority of Darebin City Council.

A plan relating to this notice may be viewed without charge at the office of Property Services Department, VicRoads, 4th Floor, North Building, 60 Denmark Street, Kew during the hours 9.00 am to 4.00 pm.

Dated 19 September 2002

For and on behalf of
Darebin City Council
ADRIAN O'BRIEN,
Acting Manager
Property Services Department.
Acting as agent for
Darebin City Council

Land Acquisition and Compensation Act 1986

FORM 7

S.21

Reg. 16

Notice of Acquisition

Compulsory Acquisition of Interest in Land

Darebin City Council declares that by this notice it acquires the following interests in the land described as the whole of Lot 3054 on Plan of Subdivision 8538, Parish of Keelbundora and being land described in Certificate of Title Volume 8164, Folio 617 and known as Lot 3054 Shiers Street, Reservoir, Vic. 3073.

Interest Acquired: That of Ferdinando Butera and all other interests.

Published with the Authority of Darebin City Council.

A plan relating to this notice may be viewed without charge at the office of Property Services

Department, VicRoads, 4th Floor, North Building, 60 Denmark Street, Kew during the hours 9.00 am to 4.00 pm.

Dated 19 September 2002

For and on behalf of
Darebin City Council
ADRIAN O'BRIEN,
Acting Manager
Property Services Department.
Acting as agent for
Darebin City Council

Land Acquisition and Compensation Act 1986

FORM 7

S.21

Reg. 16

Notice of Acquisition

Compulsory Acquisition of Interest in Land

Darebin City Council declares that by this notice it acquires the following interest in the land described as the whole of Lot 3055 on Plan of Subdivision 8538, Parish of Keelbundora and being land described in Certificate of Title Volume 7334, Folio 792 and known as Lot 3055 Shiers Street, Reservoir, Vic. 3073.

Interest Acquired: That of Luciano Francesco & Maria Bonomy and all other interests.

Published with the Authority of Darebin City Council.

The Survey plan referred to this notice may be viewed without charge at the office of Property Services Department, VicRoads, 4th Floor, North Building, 60 Denmark Street, Kew during the hours 9.00 am to 4.00 pm.

Dated 19 September 2002

For and on behalf of
Darebin City Council
ADRIAN O'BRIEN,
Acting Manager
Property Services Department.
Acting as agent for
Darebin City Council

Land Acquisition and Compensation Act 1986

FORM 7

S.21

Reg. 16

Notice of Acquisition

Compulsory Acquisition of Interest in Land

Darebin City Council declares that by this notice it acquires the following interest in the land described as the whole of Lot 3056 on Plan of Subdivision 8538, Parish of Keelbundora and

2550 G 38 19 September 2002

Victoria Government Gazette

being land described in Certificate of Title Volume 8232, Folio 203 and known as Lot 3056 Shiers Street, Reservoir, Vic. 3073.

Interest Acquired: That of Margaret Eileen Savage and all other interests.

Published with the Authority of Darebin City Council.

A plan relating to this notice may be viewed without charge at the office of Property Services Department, VicRoads, 4th Floor, North Building, 60 Denmark Street, Kew during the hours 9.00 am to 4.00 pm.

Dated 19 September 2002

For and on behalf of
Darebin City Council
ADRIAN O'BRIEN,
Acting Manager
Property Services Department.
Acting as agent for
Darebin City Council

Land Acquisition and Compensation Act 1986

FORM 7 S.21
Reg. 16

Notice of Acquisition

Compulsory Acquisition of Interest in Land

Darebin City Council declares that by this notice it acquires the following interest in the land described as the whole of Lot 2630 on Plan of Subdivision 8653, Parish of Keelbundora and being land described in Certificate of Title Volume 8323, Folio 350 and known as Lot 2630 Greig Street, Reservoir, Vic. 3073.

Interest Acquired: That of Patricia Stafford as Executor for the Estate of William Stafford and all other interests.

Published with the Authority of Darebin City Council.

A plan relating to this notice may be viewed without charge at the office of Property Services Department, VicRoads, 4th Floor, North Building, 60 Denmark Street, Kew during the hours 9.00 am to 4.00 pm.

Dated 19 September 2002

For and on behalf of
Darebin City Council
ADRIAN O'BRIEN,
Acting Manager
Property Services Department.
Acting as agent for
Darebin City Council

Land Acquisition and Compensation Act 1986

FORM 7 S.21
Reg. 16

Notice of Acquisition

Compulsory Acquisition of Interest in Land

Darebin City Council declares that by this notice it acquires the following interest in the land described as the whole of Lot 1 on Plan of Subdivision 71210, Parish of Keelbundora and being land described in Certificate of Title Volume 8603, Folio 260 and known as Lot 1 Greig Street, Reservoir, Vic. 3073.

Interest Acquired: That of Estate of Giza Epstein and all other interests.

Published with the Authority of Darebin City Council.

A plan relating to this notice may be viewed without charge at the office of Property Services Department, VicRoads, 4th Floor, North Building, 60 Denmark Street, Kew during the hours 9.00 am to 4.00 pm.

Dated 19 September 2002

For and on behalf of
Darebin City Council
ADRIAN O'BRIEN,
Acting Manager
Property Services Department.
Acting as agent for
Darebin City Council

Land Acquisition and Compensation Act 1986

FORM 7 S.21
Reg. 16

Notice of Acquisition

Compulsory Acquisition of Interest in Land

Darebin City Council declares that by this notice it acquires the following interest in the land described as the whole of Lot 3070 on Plan of Subdivision 8538, Parish of Keelbundora and being land described in Certificate of Title Volume 8210, Folio 603 and known as Lot 3070 Greig Street, Reservoir, Vic. 3073.

Interest Acquired: That of George Thomas Nicholls and all other interests.

Published with the Authority of Darebin City Council.

Victoria Government Gazette

G 38 19 September 2002 2551

A plan relating to this notice may be viewed without charge at the office of Property Services Department, VicRoads, 4th Floor, North Building, 60 Denmark Street, Kew during the hours 9.00 am to 4.00 pm.

Dated 19 September 2002

For and on behalf of
Darebin City Council
ADRIAN O'BRIEN,
Acting Manager
Property Services Department.
Acting as agent for
Darebin City Council

Land Acquisition and Compensation Act 1986

FORM 7 S.21
Reg. 16

Notice of Acquisition

Compulsory Acquisition of Interest in Land

Darebin City Council declares that by this notice it acquires the following interest in the land described as the whole of Lot 3607 on Plan of Subdivision 8538, Parish of Keelbundora and being land described in Certificate of Title Volume 8211, Folio 321 and known as Lot 3067 Greig Street, Reservoir, Vic. 3073.

Interest Acquired: That of Athol Keith, Shaun Brett and Georgina Marie Griffin executors of the Estate of Kevin Roy Griffin and all other interests.

Published with the Authority of Darebin City Council.

A plan relating to this notice may be viewed without charge at the office of Property Services Department, VicRoads, 4th Floor, North Building, 60 Denmark Street, Kew during the hours 9.00 am to 4.00 pm.

Dated 19 September 2002

For and on behalf of
Darebin City Council
ADRIAN O'BRIEN,
Acting Manager
Property Services Department.
Acting as agent for
Darebin City Council

Land Acquisition and Compensation Act 1986

FORM 7 S.21
Reg. 16

Notice of Acquisition

Compulsory Acquisition of Interest in Land

Darebin City Council declares that by this notice it acquires the following interest in the land described as the whole of Lot 3066 on Plan of Subdivision 8538, Parish of Keelbundora and being land described in Certificate of Title Volume 8211, Folio 322 and known as Lot 3066 Greig Street, Reservoir, Vic. 3073.

Interest Acquired: That of Remo Sgro and all other interests.

Published with the Authority of Darebin City Council.

A plan to this notice may be viewed without charge at the office of Property Services Department, VicRoads, 4th Floor, North Building, 60 Denmark Street, Kew during the hours 9.00 am to 4.00 pm.

Dated 19 September 2002

For and on behalf of
Darebin City Council
ADRIAN O'BRIEN,
Acting Manager
Property Services Department.
Acting as agent for
Darebin City Council

Melbourne City Link Act 1995

DECLARATION EXCLUDING LAND FROM INTERIM OPERATION PROVISIONS

I, Peter Batchelor, Minister for Transport and Minister administering the **Melbourne City Link Act 1995** ("the Act"), acting under the power conferred by section 60A(2) of the Act, by this Order declare that Section 60A of the Act no longer applies to the land shown as Crown Allotment 20C of Section 59, Parish of Melbourne South, City of Port Melbourne, on the plan numbered OP119349-B lodged in the Central Plan Office.

This Order takes effect on and from the date it is published in the Government Gazette.

Dated 3 September 2002

PETER BATCHELOR
Minister for Transport

Mineral Resources Development Act 1990EXEMPTION FROM EXPLORATION
LICENCE OR MINING LICENCE

I, Richard Aldous, Executive Director Energy and Minerals, pursuant to section 7 of the **Mineral Resources Development Act 1990** and under delegation by the Minister for Energy and Resources –

1. HEREBY EXEMPT all that Crown land situated within the boundaries of exploration licence application 4700 that has been excised from the application, from being subject to an exploration licence or mining licence.
2. Subject to paragraph 3, this exemption applies until the expiration of 2 years after the grant of the licence (if the licence is granted), or until the expiration of 28 days after the application lapses or is withdrawn or refused.
3. This exemption is REVOKED in respect of any land that ceases to lie within the boundaries of the application or licence, at the expiration of 28 days after the said land ceases to lie within the boundaries of the application or licence.

Dated 11 September 2002

RICHARD ALDOUS
Executive Director
Energy and Minerals

Pathology Services Accreditation Act 1984INQUIRY INTO APPLICATION FROM
KANINA BANNER PTY LTD FOR
ACCREDITATION OF GENERAL
DIAGNOSTIC LABORATORIES,
BURWOOD (NOW TRADING AS
PATHLAB)

The Pathology Services Accreditation Board, sitting as an Inquiry Panel with the membership of Dr Alan Gregory (Chairman) Ms Geraldine Bollard, Ms Nina Davidson, Dr Nicholas Demediuk and Dr Mary Jo Waters, has decided as follows in relation to the application from Kanina Banner Pty Ltd for accreditation of General Diagnostic Laboratories (now trading as PathLab) at 68 Burwood Highway, Burwood as a Category G accredited pathology service pursuant to section 13(8) of the **Pathology Services Accreditation Act 1984**.

After duly considering all the evidence and material placed before it at the Inquiry, the Board has decided to accept the findings and conclusions of the NATA reports of the assessments held on 10 July 2001 and 19 March 2002 of the gynaecological cytology testing conducted by General Diagnostic Laboratories. As a consequence, the Board finds that the pathology service's testing in the area of gynaecological cytology has failed to meet the standards and requirements prescribed by the Act and the Pathology Services Accreditation (General) Regulations 2001 and the Board has therefore determined that the testing is not of a suitable standard to receive accreditation.

The Board has also considered the NATA report of the assessment held on 19 March 2002 at General Diagnostic Laboratories in relation to the pathology service's testing in areas other than gynaecological cytology. While the NATA report showed the testing to be generally satisfactory, it stipulated a number of requirements regarding remedial action to be taken by the service. After examining the service's written response of 3 June 2002 to the NATA report the Board is satisfied that General Diagnostic Laboratories has taken appropriate action on the requirements listed in the report. Accordingly, the Board finds that the pathology service's testing in areas other than gynaecological cytology is now in conformity with the standards and requirements prescribed by the Act and the Pathology Services Accreditation (General) Regulations 2001 and the Board has therefore determined that this testing is of an appropriate standard to be accredited.

In view of the above adverse determination regarding the gynaecological cytology testing conducted by the pathology service, the Board has decided to impose a limitation on the service's accreditation as set out in the decision that follows:

The Board has decided, pursuant to section 13(8) of the Act, and subject to the limitation specified below, to grant accreditation to General Diagnostic Laboratories (now trading as PathLab) at 68 Burwood Highway, Burwood (Accreditation No 531) under the proprietorship of Kanina Banner Pty Ltd as a Category G accredited pathology service.

In granting accreditation to the pathology service, the Board has decided pursuant to section 17A(1) of the Act to impose a limitation on the accreditation of the service by excluding gynaecological cytology tests from the tests that it can perform as a Category G accredited service.

Dated 10 September 2002

DENIS REDMOND
Registrar
Pathology Services Accreditation Board

Prevention of Cruelty to Animals Act 1986

DRAFT CODE OF PRACTICE FOR THE PRIVATE KEEPING OF REPTILES

Public comments and submissions are invited on a draft Code of Practice for the Private Keeping of Reptiles to be made under section 7 of the **Prevention of Cruelty to Animals Act 1986**.

A copy of the draft Code may be obtained from the Bureau of Animal Welfare, 475 Mickleham Road, Attwood 3049, the Customer Service Centre by phoning 136 186 (between 8am to 8pm), at the DNRE Information Centre, Ground Floor, 8 Nicholson Street, East Melbourne 3002 or on the internet at <http://www.nre.vic.gov.au>.

Written comments and submissions on the draft Code must be made to the Senior Project Officer, Bureau of Animal Welfare, 475 Mickleham Road, Attwood, Victoria 3049 by 25 October 2002.

Dated 3 September 2002

KEITH HAMILTON
Minister for Agriculture

Public Lotteries Act 2000

NOTICE OF MAKING OF RULES UNDER SECTION 9

Tattersall's Sweeps Pty Ltd ACN 081 925 662 of 615 St Kilda Road, Melbourne hereby gives notice of the making of the following Rules to be effective from 28 September 2002: Tattslotto – Definition of "Claim Period", Rules 4.1, 5.1, 5.2, 5.3, 9.9, Schedule A and Schedule B; Wednesday Tattslotto – Definition of "Claim Period", Rules 4.1, 5.1, 5.2 and 9.7(c); Powerball – Definition of "Claim Period", Rules

4.1, 5.1, 5.2, and 9.10; OzLotto – Definition of "Claim Period", Rules 4.1, 5.1, 5.2, 9.3 and 9.10; Super 66 – Definition of "Claim Period", Rules 4.1, 5.1, 9.8 and 15.11; Tatts 2 – Definition of "Claim Period", Rules 4.1, 5.1, 5.2 and 15.10; Tatts Keno – Definition of "Claim Period", Rules 4.1, 5.1 and 15.10; The Pools – Definition of "Claim Period", Rules 4.1, 5.1, 5.2, 9.10, 15.3, 15.7, 15.8, 15.10(b) and Schedule A; Instant Lotteries – Definitions of "Claim Period", "GST Act" and "public lottery", Rules 2.3, 3.1(h) through (n) inclusive; 3.2, 5.1, 5.2, 6.1, 6.2, 8.1 through 8.14 inclusive; 9.1, 9.3, 11.1(f), (g) and (h), 12.2 and 13.1.

DUNCAN FISCHER
Chief Executive Officer

Subordinate Legislation Act 1994

NOTICE OF PREPARATION OF REGULATORY IMPACT STATEMENT

Forests (You Yangs Regional Park)
Regulations 2002

Notice is given under section 11 of the **Subordinate Legislation Act 1994** that a Regulatory Impact Statement (RIS) has been prepared in relation to the proposed Forests (You Yangs Regional Park) Regulations 2002.

The objective to be achieved by the proposed regulations is to make provision for the management of the You Yangs Regional Park.

The reason for the proposed regulations is to replace the existing Forests (You Yangs Regional Park) Regulations 1992, which 'sunset' or expire on 30 November 2002. The proposed regulations will provide an on-going framework for the management and administration of the You Yangs Regional Park (situated between Geelong and Melbourne).

The RIS examined two alternatives to the proposed Forests (You Yangs Regional Park) Regulations 2002:

- (a) Regional education and information program;
- (b) Voluntary code(s) of practice.

The RIS demonstrates that the proposed regulations are the most effective means of meeting the objectives by establishing an enforceable framework for the management and administration of the park. The proposed

2554 G 38 19 September 2002

Victoria Government Gazette

regulations are designed specifically to ensure the adequate care and protection of the park.

Copies of the proposed regulations and accompanying RIS may be obtained from the Information Centre, Department of Natural Resources and Environment, 8 Nicholson Street, East Melbourne, Victoria 3002 (phone 9637 8080) between 8.30 and 5.30 p.m. Alternatively, the proposed regulations and accompanying RIS are located at <http://www.nre.vic.gov.au/ris/>.

Public comments or submissions on the proposed regulations and RIS are invited. All comments or submissions must be in writing and must be received by the Parks Flora and Fauna Division (Attention Mr G. Niewand), Department of Natural Resources and Environment, Level 14, 8 Nicholson Street, East Melbourne, Victoria 3002 or on gary.niewand@nre.vic.gov.au by no later than 5.30 pm on 18 October 2002.

All submissions will be treated as public documents.

SHERRYL GARBUTT
Minister for Environment
and Conservation

The Government Superannuation Act 1999
ELECTION OF THREE (3) DIRECTORS
AND THREE (3) DEPUTIES OF
DIRECTORS TO THE GOVERNMENT
SUPERANNUATION OFFICE BOARD

Notice is hereby given that, in accordance with the Government Superannuation Office 2002 Board Election Procedures, I declare Jennifer Cassidy with Melinda Freyer, Barbra Norris with Andrew Skourdoumbis and William Lyons with Alexander Gagachef duly elected for appointment as directors with deputy directors of the Government Superannuation Office Board in accordance with section 10 of **The Government Superannuation Act 1999**.

SHIRLEY BEAN
Returning Officer

Transport Act 1983
TOW TRUCK DIRECTORATE OF
VICTORIA

Tow Truck Application

Notice is hereby given that the following applications will be considered by the Licensing Authority after 2 October 2002.

Notice of any objection to the granting of an application should be forwarded to reach the

Director, Tow Truck Directorate of Victoria, Level 6, 14–20 Blackwood Street, North Melbourne (PO Box 666, North Melbourne 3051) not later than 26 September 2002.

It will not be necessary for interested parties to appear on the date specified, unless advised in writing.

S.V.G. Towing Services Pty Ltd.
Amendment to previous Gazette Notice 11/07/2002.

This notice corrects a previous notice which appeared in the Victoria Government Gazette No. G35 dated 29/08/2002 in the name of SVG Towing Service Pty Ltd as the applicant. The application was gazetted incorrectly and the following notice is now substituted. Objections will need to be resubmitted to accord with the **Transport Act 1983**.

Application for variation of conditions of tow truck licence numbers TOW105 and TOW808 which authorise the licensed vehicle to be operated under the following conditions:

1. the licensed vehicles shall be managed, controlled and operated from the depot situated at 167–169 City Road, South Melbourne;
2. the licensed vehicle shall be used for the purpose of lifting and carrying or lifting and towing damaged or disabled motor vehicles –
 - (a) from an accident scene occurring in the “Controlled Area” to the authorised depot shown above or to the place specified by the owner or person in charge of the damaged or disabled motor vehicle or by a member of the Victoria Police, an officer of the licensing authority or Roads Corporation provided that before such damaged or disabled motor vehicle with a gross vehicle mass of less than 4.0 tonnes is removed from the scene of an accident in the said “Controlled Area” the permission of the Allocation Centre is given and an allocation number has been given;
 - (b) from an accident scene occurring outside the “Controlled Area” to any place in Victoria provided that the written authorisation of the licensing authority is first given to the owner of the licensed truck;
 - (c) from any place other than accident scenes to any place in Victoria;
3. the licensed tow truck, when in attendance at

an accident scene, must be capable of towing, or equipped to enable it to tow or carry any damaged motor vehicle, which is within the legal capacity of the tow truck.

To vary the above conditions to show as follows:

1. the licensed vehicles shall be managed, controlled and operated from the depot situated at 53 Church Street, Abbotsford;
2. the licensed vehicle shall be used for the purpose of lifting and carrying or lifting and towing damaged or disabled motor vehicles –
 - (a) from an accident scene occurring in the “Controlled Area” to the authorised depot shown above or to the place specified by the owner or person in charge of the damaged or disabled motor vehicle or by a member of the Victoria Police, an officer of the licensing authority or Roads Corporation provided that before such damaged or disabled motor vehicle with a gross vehicle mass of less than 4.0 tonnes is removed from the scene of an accident in the said “Controlled Area” the permission of the Allocation Centre is given to Depot 756 and an allocation number has been given;
 - (b) from an accident scene occurring outside the “Controlled Area” to any place in Victoria provided that the written authorisation of the licensing authority is first given to the owner of the licensed truck;
 - (c) from any place other than accident scenes to any place in Victoria;
3. the licensed tow truck, when in attendance at an accident scene, must be capable of towing, or equipped to enable it to tow or carry any damaged motor vehicle, which is within the legal capacity of the tow truck;
4. the allocation boundary of Depot 756 as determined by the Tow Truck Directorate of Victoria will include part, if not all of the following suburbs:
 South Yarra, Melbourne 3004, Prahran, Windsor, St. Kilda, St. Kilda East, Balaclava, Elwood, Armadale, Toorak, Brighton, Elsternwick, Caulfield, Caulfield South, Caulfield North and Kooyong.

Dated 19 September 2002

STEVE STANKO
 Director

Victorian Environmental Assessment Council Act 2001

TERMS OF REFERENCE

The Minister for Environment and Conservation has made the following request to the Victorian Environmental Assessment Council. The request was made on 8 September 2002.

Pursuant to s.15 of the **Victorian Environmental Assessment Council Act 2001**, the Victorian Environmental Assessment Council is requested to carry out an investigation of the Angahook–Lorne State Park to determine its potential for designation as a national park.

The area to be included in the investigation is:

- the existing Angahook-Lorne State Park as described in Part 1 of Schedule Two B to the **National Parks Act 1975**;
- public lands in the vicinity of Angahook–Lorne State Park, particularly areas adjacent to Anglesea, the coastline and the Great Ocean Road.

The Council is required to prepare a discussion paper and draft proposal paper, and submit a written report on the outcome of its investigation, within fifteen months of the request for the investigation being made.

Having regard to the matters to be taken into account in the investigations as provided in s.18 of the Act, the Council must also have regard to the:

- Victorian Government’s Great Ocean Road Region Strategy;
- Point Addis Marine National Park (to be created on 16 November 2002);
- West Victoria Regional Forest Agreement between the Commonwealth Government and the State of Victoria;
- Victorian Coastal Strategy;
- Anglesea Heathland Agreement between the Secretary to the Department of Natural Resources and Environment and Alcoa Australia Limited;
- Great Ocean Road Regional Tourism Development Plan;
- definitions of national and State parks used by the former Land Conservation Council and the former Environment Conservation Council;
- objects of the National Parks Act with respect to national and State parks
- Corangamite Regional Catchment Strategy.

2556 G 38 19 September 2002

Victoria Government Gazette

Crown Land (Reserves) Act 1978
ORDER GIVING APPROVAL TO GRANT OF A LEASE
UNDER SECTIONS 17D AND 17DA

Under sections 17D and 17DA of the **Crown Land (Reserves) Act 1978** I, Sherryl Garbutt, Minister for Environment and Conservation, being satisfied that there are special reasons which make the granting of a lease reasonable and appropriate in the particular circumstances and to do this will not be substantially detrimental to the use and enjoyment of any adjacent land reserved under the **Crown Land (Reserves) Act 1978**, approve the granting of a lease by the Yarra Bend Park Trust for a Survey School over the area of the Yarra Bend Park described in the Schedule below and, in accordance with section 17D(3)(a) of the **Crown Land (Reserves) Act 1978**, state that –

- (a) there are special reasons which make granting the lease reasonable and appropriate in the particular circumstances; and
- (b) to do this will not be substantially detrimental to the use and enjoyment of any adjacent land reserved under the **Crown Land (Reserves) Act 1978**.

SCHEDULE

The land shown by hatching on the attached plan, being part of the land permanently reserved for Public Park and Recreation by Order in Council of 26 March 1935 (vide Government Gazette of 3 April 1935, page 1096). — Rs 4368.

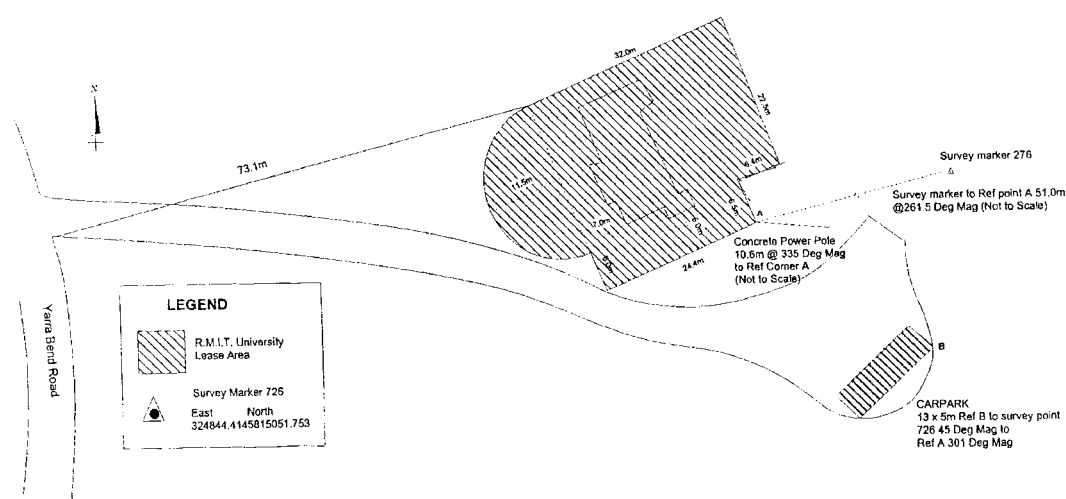

Dated 27 May 2002

SHERRYL GARBUTT MP
 Minister for Environment and Conservation

Private Agents Act 1966

NOTICE OF RECEIPT OF APPLICATIONS FOR LICENCES UNDER THE PROVISIONS OF THE PRIVATE AGENTS ACT 1966

I, the undersigned, being the Registrar of the Magistrates' Court at Melbourne hereby give notice that applications, as under, have been lodged for hearing by the said Court on the date specified.

Any person desiring to object to any of such applications must:—

- (a) lodge with me a notice in the prescribed form of his objection and of the grounds thereof;
- (b) cause a copy of such notice to be served personally or by post upon the applicant at least three days before the hearing of the application; and

(c) send or deliver

- (i) where the objection is not made by the officer in charge of the police district in which the Court is situated — a copy of the notice to such officer; and
- (ii) where the objection is not made by the Registrar or Deputy Registrar — a copy to the Registrar.

<i>Full name of Applicant or in the case of a Firm or Corporation, of the Nominee</i>	<i>Place of Abode of Applicant or Nominee</i>	<i>Name of Firm or Corporation</i>	<i>Address for Registration</i>	<i>Type of Licence</i>	<i>Date of Hearing of Application</i>
Danny James Ross	3 Mercer Road, Armadale	Knight Dae Australia P/L	2/2 Wellington Parade, East Melbourne	Commercial Agent	1/10/02
Maria Christine Jurisic	116 Wright Street, Sunshine	Action Mercantile P/L	2/10 Queens Road, Melbourne	Commercial Sub-Agent	1/10/02
Jeanna Foster	7 Venus Street, Caulfield South	Action Mercantile P/L	2/10 Queens Road, Melbourne	Commercial Sub-Agent	1/10/02
Aaron Dean Michael Frazier	12-79 Cleeland Street, Dandenong	Repol Victoria	424 St Kilda Road, Melbourne	Commercial Sub-Agent	9/10/02
Lisa Marie Hanko	8 Orli Court, Wheelers Hill	Consolidated Collections Australia P/L	214 Balaclava Road, North Caulfield	Commercial Sub-Agent	11/10/02

Dated at Melbourne 13 September 2002

MIKE O'CONNOR
Registrar of the Magistrates' Court

Road Safety Act 1986
ORDER UNDER SECTION 98
ROAD SAFETY ACT 1986 EXTENDING PROVISIONS TO PORTIONS OF THE STANLEY
AVENUE CARPARK AT
6-10 STANLEY AVENUE, CHELTENHAM

I, Rob Gilpin, Acting Regional Manager, VicRoads Metropolitan South East Region, delegate of the Minister for Transport under Section 98 of the **Road Safety Act 1986** by this Order extend the application of:

- (a) Sections 59, 64, 65, 76, 77, 85-90, 99 and 100 of that Act; and
 - (b) The Road Safety (Road Rules) Regulations 1999; and
 - (c) Parts 7 and 8 and Schedules 5 and 6 of the Road Safety (Procedures) Regulations 1988
- to portions of the Stanley Avenue carpark at 6-10 Stanley Avenue, Cheltenham within the City of Kingston, particulars of which are shown on the attached plan.

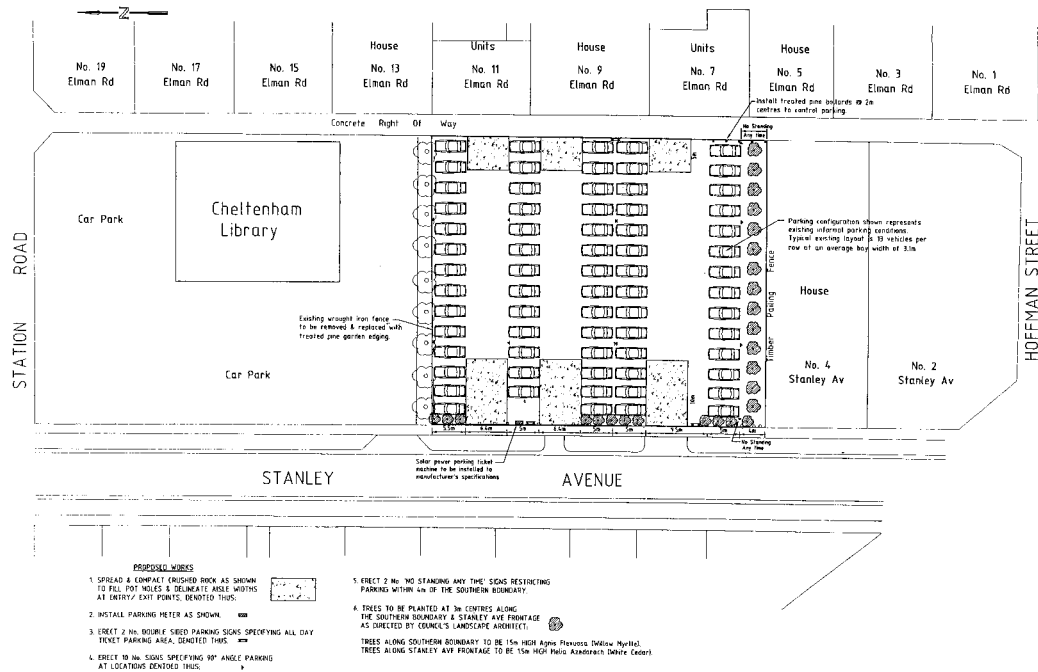

Dated 6 September 2002

ROB GILPIN
 Acting Regional Manager

Melbourne and Metropolitan Board of Works Act 1958

NOTICE OF DETERMINATION

In accordance with Section 281A (1) – (3) of the **Melbourne and Metropolitan Board of Works Act 1958** and with Section 139 (3A) – (3C) of the **Water Industry Act 1994**, the Valuer-General has determined the following valuation equalisation factors. These are the factors by which, in the opinion of the Valuer-General, the net annual value of land within the specified area or postcode determined, as at 1 January 2002, ought to be multiplied if the net annual value of the land is to accord with levels of value generally prevailing in that area as at 30 June 1990.

Postcode	Suburb or Area	Residential Equalisation Factor	Commercial Equalisation Factor	Industrial Equalisation Factor
3000	Melbourne	0.75	1.03	1.05
3002	Melbourne East, Jolimont	0.62	1.00	1.09
3003	Melbourne West	0.56	1.08	1.15
3004	St Kilda Road (City of Melbourne)	0.76	0.93	1.18
3005	World Trade Centre	0.69	0.90	0.98
3006	Southbank	0.71	1.12	1.14
3008	Docklands	0.71	0.74	0.97
3011	Coode Island (Melbourne)	na	na	0.97
3011	Footscray, Seddon (Maribyrnong)	0.44	1.07	0.99
3012	Brooklyn (Brimbank)	0.50	1.01	1.00
3012	Brooklyn (Hobsons Bay)	0.50	1.01	1.00
3012	Tottenham, Footscray West, Maidstone (Maribyrnong)	0.48	1.00	1.14
3013	Yarraville	0.41	0.82	1.09
3015	Newport, Spotswood	0.42	0.84	1.00
3016	Williamstown	0.38	0.84	0.93
3018	Altona	0.47	0.84	0.93
3019	Braybrook	0.59	1.10	1.09
3020	Sunshine	0.68	1.01	1.00
3021	St Albans, Albanville, Kealba, Kings Park	0.73	1.02	0.94
3022	Ardeer	0.75	1.02	0.93
3023	Deer Park (Brimbank)	0.75	1.01	1.00
3023	Burnside, Caroline Springs, Ravenhall (Melton)	0.75	1.05	1.10
3024	Wyndham Vale	0.73	1.00	1.03
3025	Altona North	0.50	0.85	0.94
3026	Laverton North	na	0.89	0.95
3027	Laverton RAAF	0.64	0.93	0.91
3028	Altona Meadows, Seabrook (Hobsons Bay)	0.66	1.02	1.10
3028	Laverton, Laverton North (Wyndham)	0.66	1.00	1.10
3029	Hoppers Crossing, Tarneit, Truganina (Wyndham)	0.71	0.89	0.95
3029	Truganina (Melton)	0.74	0.91	1.12
3030	Werribee, Werribee South, Point Cook (Wyndham)	0.74	0.93	1.10
3030	Derrimut (Brimbank)	0.75	0.91	1.12
3031	Flemington, Kensington (Melbourne)	0.47	0.89	0.95

Postcode	Suburb or Area	Residential Equalisation Factor	Commercial Equalisation Factor	Industrial Equalisation Factor
3031	Flemington, Kensington (Moonee Valley)	0.48	0.82	0.91
3032	Maribyrnong, Highpoint Shopping Centre (Maribyrnong)	0.49	0.83	0.99
3032	Ascot Vale (Moonee Valley)	0.48	0.85	0.97
3033	Keilor East (Brimbank)	0.57	0.88	1.01
3033	Keilor East (Moonee Valley)	0.57	0.87	0.99
3034	Avondale Heights	0.56	0.87	1.05
3036	Keilor	0.64	1.02	1.00
3037	Sydenham, Keilor North, Delahey (Brimbank)	0.68	0.88	1.01
3037	Hillside, Taylors Hill (Melton)	0.68	0.83	1.10
3038	Taylors Lakes, Keilor Downs, Keilor Lodge	0.73	0.88	1.01
3039	Moonee Ponds	0.45	0.93	0.90
3040	Essendon, Essendon West	0.46	0.79	0.82
3041	Strathmore, Essendon North	0.41	0.80	0.86
3042	Keilor Park (Brimbank)	0.53	0.87	0.93
3042	Airport West, Niddrie (Moonee Valley)	0.53	0.86	0.90
3043	Tullamarine (Brimbank)	0.63	0.88	1.00
3043	Tullamarine (Hume)	0.63	0.91	1.00
3043	Tullamarine (Moreland)	0.63	0.91	0.95
3044	Pascoe Vale	0.51	0.74	0.84
3045	Melbourne Airport	na	0.91	1.01
3046	Glenroy	0.56	0.83	0.96
3047	Broadmeadows	0.65	0.91	0.83
3048	Coolaroo	0.68	0.91	0.83
3049	Westmeadows	0.67	0.91	0.83
3050	Royal Melbourne Hospital	0.54	0.90	0.91
3051	North Melbourne (Melbourne)	0.54	0.98	0.99
3051	North Melbourne (Moonee Valley)	0.56	0.88	0.96
3052	Parkville	0.54	0.90	0.91
3053	Carlton	0.54	0.86	0.96
3054	Carlton North	0.48	0.77	0.87
3055	Brunswick West	0.45	0.73	0.96
3056	Brunswick	0.47	0.78	0.88
3057	Brunswick East	0.46	0.83	0.92
3058	Coburg	0.48	0.83	0.88
3059	Greenvale	0.59	0.91	0.74
3060	Fawkner	0.62	0.79	0.78
3061	Campbellfield	0.67	0.91	0.74
3062	Somerton	0.67	0.91	0.74
3063	Yuroke	0.70	0.88	0.74
3064	Craigieburn, Roxburgh Park (Hume)	0.68	0.88	0.75
3065	Fitzroy	0.42	0.76	0.75
3066	Collingwood	0.44	0.79	0.79
3067	Abbotsford	0.40	0.83	0.79
3068	Fitzroy North (Moreland)	0.42	0.78	0.77
3068	Fitzroy North, Clifton Hill (Yarra)	0.42	0.79	0.77

Postcode	Suburb or Area	Residential Equalisation Factor	Commercial Equalisation Factor	Industrial Equalisation Factor
3070	Northcote	0.45	0.80	0.88
3071	Thornbury	0.53	0.80	0.88
3072	Preston	0.53	0.80	0.88
3073	Reservoir	0.56	0.80	0.88
3074	Thomastown	0.68	0.81	0.78
3075	Lalor	0.71	0.81	0.78
3076	Epping	0.60	0.81	0.78
3078	Fairfield (Darebin)	0.46	0.80	0.88
3078	Fairfield (Yarra)	0.46	0.79	0.83
3079	Ivanhoe	0.45	0.84	0.83
3081	Heidelberg West, Heidelberg Heights	0.55	0.84	0.83
3082	Mill Park	0.60	0.81	0.79
3083	Bundoora (Banyule)	0.59	0.86	0.83
3083	Bundoora (Darebin)	0.59	0.81	0.89
3083	Bundoora (Whittlesea)	0.59	0.87	0.94
3084	Heidelberg, View Bank, Rosanna	0.52	0.86	0.83
3085	Macleod	0.53	0.86	0.83
3087	Watsonia	0.57	0.86	0.83
3088	Greensborough (Banyule)	0.59	0.85	0.83
3088	Greensborough (Nillumbik)	0.59	0.87	0.82
3089	Diamond Creek	0.72	0.88	0.82
3090	Plenty	0.70	0.88	0.82
3091	Yarrambat	0.68	0.86	0.82
3093	Lower Plenty	0.59	0.86	0.83
3094	Montmorency	0.55	0.86	0.83
3095	Eltham	0.58	0.88	1.05
3096	Wattle Glen	0.68	0.77	1.06
3097	Kangaroo Ground	0.65	0.77	1.06
3099	Hurstbridge	0.69	0.77	0.97
3101	Kew	0.48	0.83	0.80
3102	Kew East	0.47	0.83	0.80
3103	Balwyn	0.44	0.83	0.80
3104	Balwyn North	0.44	0.83	0.80
3105	Bulleen	0.53	0.84	0.83
3106	Templestowe	0.63	0.77	0.83
3107	Lower Templestowe	0.58	0.77	0.83
3108	Doncaster	0.59	0.84	0.83
3109	Doncaster East	0.61	0.84	0.83
3111	Donvale	0.63	0.77	0.83
3113	Warrandyte (Manningham)	0.66	0.77	0.83
3113	Warrandyte North (Nillumbik)	0.66	0.77	0.82
3114	Park Orchards	0.64	0.77	0.83
3115	Wonga Park	0.61	0.77	0.83
3116	Chirnside Park	0.61	0.65	0.69
3121	Richmond, Burnley	0.40	0.74	0.84
3122	Hawthorn	0.44	0.83	0.80
3123	Hawthorn East	0.46	0.83	0.80
3124	Camberwell	0.43	0.83	0.80
3125	Burwood (Boroondara)	0.44	0.83	0.80

Postcode	Suburb or Area	Residential Equalisation Factor	Commercial Equalisation Factor	Industrial Equalisation Factor
3125	Burwood (Monash)	0.44	0.86	0.70
3125	Burwood (Whitehorse)	0.45	0.86	0.72
3126	Canterbury	0.47	0.83	0.80
3127	Surrey Hills	0.47	0.76	0.80
3128	Box Hill	0.48	0.94	0.64
3129	Box Hill North	0.48	0.77	0.60
3130	Blackburn	0.56	0.80	0.64
3131	Nunawading	0.58	0.84	0.65
3132	Mitcham (Manningham)	0.60	0.77	0.79
3132	Mitcham (Whitehorse)	0.60	0.77	0.72
3133	Vermont, Vermont South	0.60	0.75	0.72
3134	Ringwood North (Manningham)	0.55	0.75	0.83
3134	Ringwood (Maroondah)	0.55	0.71	0.79
3135	Ringwood East, Heathmont	0.53	0.66	0.74
3136	Croydon	0.59	0.70	0.77
3137	Kilsyth South (Maroondah)	0.64	0.71	0.77
3137	Kilsyth (Yarra Ranges)	0.64	0.70	0.79
3138	Mooroolbark	0.69	0.70	0.74
3139	Wandin, Wandin East, Wandin North, Seville, Yellingbo, Woori Yallock	0.65	0.70	0.74
3140	Lilydale	0.64	0.65	0.69
3141	South Yarra (Melbourne)	0.60	0.86	0.88
3141	South Yarra (Stonnington)	0.55	0.80	0.81
3142	Toorak	0.53	0.77	0.78
3143	Armadale	0.48	0.77	0.84
3144	Malvern	0.49	0.83	0.89
3145	Malvern East (Stonnington)	0.51	0.90	0.89
3145	Caulfield East (Glen Eira)	0.51	0.90	0.89
3146	Glen Iris (Boroondara)	0.49	0.83	0.82
3146	Glen Iris (Stonnington)	0.49	0.83	0.87
3147	Ashburton (Boroondara)	0.47	0.83	0.80
3147	Ashwood (Monash)	0.45	0.86	0.76
3148	Chadstone (Monash)	0.50	0.90	0.86
3148	Malvern East, Chadstone Shopping Centre (Stonnington)	0.50	0.91	0.89
3149	Mount Waverley	0.55	0.90	0.76
3150	Glen Waverley	0.59	0.90	0.76
3151	Burwood East	0.54	0.80	0.79
3152	Wantirna, Wantirna South	0.62	0.83	0.92
3153	Bayswater (Knox)	0.65	0.84	0.92
3153	Bayswater North (Maroondah)	0.65	0.84	0.87
3154	The Basin	0.63	0.84	0.93
3155	Boronia	0.66	0.84	0.93
3156	Ferntree Gully, Upper Ferntree Gully, Lysterfield (Knox)	0.60	0.86	0.83
3156	Upper Ferntree Gully (Yarra Ranges)	0.60	0.81	0.79
3156	Lysterfield South (Casey)	0.60	0.81	0.79
3158	Upwey	0.62	0.67	0.79
3159	Menzies Creek, Selby (Yarra Ranges)	0.63	0.71	0.79

Postcode	Suburb or Area	Residential Equalisation Factor	Commercial Equalisation Factor	Industrial Equalisation Factor
3159	Menzies Creek (Cardinia)	0.63	0.71	0.79
3160	Belgrave, Belgrave Heights, Belgrave South, Tecoma	0.64	0.67	0.70
3161	Caulfield North	0.47	0.83	0.83
3162	Caulfield, Caulfield South	0.44	0.83	0.83
3163	Carnegie, Glen Huntly, Murrumbeena	0.44	0.83	0.83
3165	Bentleigh East	0.45	0.83	0.83
3166	Oakleigh, Oakleigh East, Hughesdale, Huntingdale	0.52	0.90	0.69
3167	Oakleigh South	0.58	0.90	0.75
3168	Clayton	0.54	0.86	0.73
3169	Clarinda, Clayton South	0.57	0.86	0.87
3170	Mulgrave	0.57	0.99	0.73
3171	Springvale	0.68	0.97	0.80
3172	Springvale South (Gr Dandenong)	0.67	0.97	0.87
3172	Dingley (Kingston)	0.67	0.97	0.87
3173	Keysborough	0.67	0.85	0.82
3174	Noble Park, Noble Park North	0.70	0.97	0.87
3175	Dandenong, Dandenong South, Bangholme	0.68	0.94	0.95
3177	Doveton, Eumemmering	0.78	0.97	0.82
3178	Rowville	0.64	0.83	0.92
3179	Scoresby	0.63	0.83	0.92
3180	Knoxfield	0.59	0.83	0.92
3181	Prahran, Windsor	0.48	0.77	0.82
3182	St Kilda, St Kilda West	0.42	0.75	0.94
3183	Ripponlea, St Kilda East (Glen Eira)	0.49	0.82	0.83
3183	Ripponlea, St Kilda East, Balaclava (Port Phillip)	0.45	0.78	0.85
3184	Elwood	0.42	0.64	0.85
3185	Elsternwick, Gardenvale	0.42	0.73	0.83
3186	Brighton	0.44	0.69	0.79
3187	Brighton East	0.46	0.69	0.79
3188	Hampton, Hampton East	0.42	0.69	0.79
3189	Moorabbin (Kingston)	0.47	0.72	0.82
3190	Highett (Bayside)	0.47	0.72	0.82
3190	Highett (Kingston)	0.47	0.72	0.82
3191	Sandringham	0.43	0.65	0.72
3192	Cheltenham (Bayside)	0.49	0.72	0.82
3192	Cheltenham (Kingston)	0.49	0.72	0.82
3193	Beaumaris, Black Rock	0.44	0.65	0.79
3194	Mentone, Moorabbin Airport	0.49	0.76	0.88
3195	Mordialloc, Aspendale, Parkdale, Braeside, Aspendale Gardens	0.50	0.87	0.88
3196	Chelsea, Edithvale, Chelsea Heights, Bonbeach	0.52	0.77	0.82
3197	Carrum, Patterson Lakes	0.51	0.77	0.89
3198	Seaford	0.68	1.12	0.84
3199	Frankston, Frankston South	0.76	1.11	0.84

Postcode	Suburb or Area	Residential Equalisation Factor	Commercial Equalisation Factor	Industrial Equalisation Factor
3200	Frankston North	0.83	0.90	0.84
3201	Carrum Downs	0.75	0.81	0.80
3202	Heatherston	0.59	0.77	0.88
3204	Bentleigh, McKinnon, Ormond	0.43	0.74	0.83
3205	South Melbourne	0.49	1.09	0.99
3206	Albert Park, Middle Park	0.43	0.71	0.84
3207	Port Melbourne, Fisherman's Bend (Melbourne)	na	1.09	1.17
3207	Port Melbourne (Port Phillip)	0.52	1.07	1.13
3211	Little River	0.76	0.93	0.96
3335	Rockbank	0.78	1.05	1.00
3337	Melton, Melton West	0.84	0.86	0.92
3338	Melton South, Exford	0.90	0.80	1.00
3427	Diggers Rest	0.80	0.91	0.95
3428	Bulla	0.76	0.93	0.95
3429	Sunbury	0.77	0.93	0.94
3752	South Morang	0.65	0.84	0.79
3754	Doreen (Nillumbik)	0.66	0.78	0.90
3754	Mernda (Whittlesea)	0.66	0.84	0.83
3755	Yan Yean (Whittlesea)	0.69	0.84	0.83
3757	Whittlesea	0.75	0.82	0.79
3759	Panton Hill	0.67	0.78	0.98
3765	Montrose	0.61	0.69	0.77
3766	Kalorama	0.60	0.70	0.79
3767	Mount Dandenong	0.62	0.70	0.79
3770	Coldstream	0.68	0.74	0.77
3775	Christmas Hills (Nillumbik)	0.65	0.77	0.82
3775	Yarra Glen (Yarra Ranges)	0.65	0.79	0.78
3777	Healesville	0.62	0.75	0.78
3781	Cockatoo	0.64	0.88	0.75
3782	Clematis, Emerald	0.63	0.88	0.75
3783	Gembrook	0.73	0.88	0.75
3785	Tremont	0.62	0.65	0.69
3786	Ferny Creek	0.61	0.65	0.69
3787	Sassafras	0.64	0.65	0.69
3788	Olinda	0.61	0.65	0.69
3789	Sherbrooke	0.60	0.65	0.69
3791	Kallista	0.63	0.70	0.69
3792	The Patch	0.65	0.70	0.69
3793	Monbulk	0.64	0.70	0.69
3795	Silvan	0.66	0.70	0.69
3796	Mount Evelyn	0.69	0.65	0.69
3797	Yarra Junction	0.66	0.65	0.74
3799	Warburton, Millgrove, Wesburn	0.69	0.70	0.73
3802	Endeavour Hills	0.73	0.84	0.82
3803	Hallam	0.70	0.84	0.81
3804	Narre Warren North (Casey)	0.70	0.75	0.81
3804	Narre Warren East (Yarra Ranges)	0.72	0.75	0.81
3805	Narre Warren, Narre Warren South	0.72	0.75	0.81

Postcode	Suburb or Area	Residential Equalisation Factor	Commercial Equalisation Factor	Industrial Equalisation Factor
3806	Berwick, Harkaway	0.71	0.83	0.82
3807	Beaconsfield, Guys Hill (Cardinia)	0.66	0.88	0.75
3807	Beaconsfield (Casey)	0.64	0.84	0.77
3808	Beaconsfield Upper	0.64	0.88	0.75
3809	Officer	0.70	0.88	0.75
3810	Pakenham	0.70	0.87	0.74
3812	Maryknoll, Nar Nar Goon	0.79	0.90	0.75
3813	Tynong	0.87	0.90	0.75
3814	Cora Lynn, Garfield, Garfield North, Vervale	0.81	0.90	0.75
3815	Bunyip, Iona, Tonimbuk	0.77	0.90	0.75
3816	Labertouche, Longwarry, Modella	0.91	0.86	0.83
3818	Drouin, Athlone, Hallora, Jindivic, Ripplebrook, Rokeby, Tarago	0.80	0.90	0.83
3820	Warragul	0.73	0.78	0.82
3821	Crossover, Nayook	0.87	0.95	0.83
3831	Neerim South	0.77	0.86	0.83
3833	Noojee	0.82	0.90	0.83
3910	Langwarrin	0.74	0.73	0.81
3911	Baxter (Mornington Peninsula)	0.75	0.93	0.82
3911	Langwarrin South (Frankston)	0.75	0.73	0.81
3912	Pearcedale (Casey)	0.68	0.95	0.88
3912	Pearcedale, Somerville (Mornington Peninsula)	0.66	0.93	0.94
3913	Tyabb	0.71	0.93	0.94
3915	Hastings	0.67	1.07	1.06
3916	Merricks, Point Leo, Shoreham	0.64	0.89	1.08
3918	Bittern	0.65	1.07	1.08
3919	Crib Point	0.72	1.07	1.07
3920	HMAS Cerberus	0.70	na	1.08
3926	Balnarring, Balnarring Beach, Merricks Beach, Merricks North	0.63	1.07	1.08
3927	Somers	0.61	0.89	1.08
3928	Main Ridge	0.54	1.06	1.07
3929	Flinders	0.46	0.92	1.07
3930	Mount Eliza	0.61	0.92	1.07
3931	Mornington	0.56	0.81	0.82
3933	Moorooduc, Tuerong	0.60	0.88	1.07
3934	Mount Martha	0.58	1.06	1.08
3936	Dromana, Arthurs Seat	0.61	1.02	0.91
3937	Red Hill, Red Hill South	0.60	0.78	0.97
3938	McCrae	0.62	0.98	1.19
3939	Rosebud, Rosebud West, Boneo, Cape Schanck, Fingal, St Andrews Beach	0.65	1.02	1.19
3941	Rye, Tootgarook	0.60	1.01	1.19
3942	Blairgowrie	0.53	0.87	1.19
3943	Sorrento	0.43	1.06	1.03
3944	Portsea, Point Nepean	0.50	0.77	1.03

2566 G 38 19 September 2002

Victoria Government Gazette

Postcode	Suburb or Area	Residential Equalisation Factor	Commercial Equalisation Factor	Industrial Equalisation Factor
3975	Lyndhurst, Lynbrook (Casey)	0.66	0.95	0.82
3975	Lyndhurst (Gr Dandenong)	0.66	0.98	0.74
3976	Hampton Park (Casey)	0.73	0.94	0.82
3977	Cranbourne, Cranbourne West, Cranbourne North, Cranbourne South, Five Ways, Devon Meadows, Cannons Creek (Casey)	0.73	0.84	0.82
3977	Skye (Frankston)	0.76	0.92	0.86
3978	Clyde, Clyde North, Cardinia	0.74	0.97	0.83
3980	Tooradin, Warneet, Blind Bight	0.78	0.95	0.83
3981	Bayles, Koo Wee Rup, Catani, Dalmore, Heath Hill, Yannathan	0.81	0.90	0.76
3984	Lang Lang, Caldermeade	0.78	0.90	0.76
3987	Nyora	0.94	0.93	0.98
3988	Poowong, Mountain View	0.85	0.93	0.98

**AGREEMENT FOR THE MELBOURNE CITY LINK AND AGREEMENT FOR THE
EXHIBITION STREET EXTENSION PROJECT**

Notice under Schedule 4 of the Agreement for Integrating and Facilitating the Project and the Exhibition Street Extension Project between the Crown in right of the State of Victoria, CityLink Melbourne Limited, Perpetual Trustee Company Limited, City Link Management Limited and City Link Extension Pty Limited (the "IFA") (as substituted for (and as if incorporated in lieu of) Schedule 3 of the Agreement for the Melbourne City Link between the Crown in right of the State of Victoria, CityLink Melbourne Limited, Perpetual Trustee Company Limited and City Link Management Limited (the "Concession Deed") and Schedule 1 of the Agreement for the Exhibition Street Extension Project between the Crown in right of the State of Victoria and City Link Extension Pty Limited ("the ESEP Deed"))).

CityLink Melbourne Limited (ABN 65 070 810 678) (for itself and as agent of City Link Extension Pty Limited (ABN 40 082 058 615)) ("CityLink Melbourne") gives notice of the following Charge Tolls, Maximum Charge Tolls, Day Tolls, Taxi Tolls and Taxi Day Tolls for the Melbourne City Link and the Exhibition Street Extension:

Schedule of Charge Tolls and Maximum Charge Tolls

Charge Tolls (\$/vehicle)

Category of Vehicle Tollable Section	Car	Light Commercial Vehicle	Heavy Commercial Vehicle	Motor Cycle
Tullamarine Freeway Upgrade, between Moreland Road and Brunswick Road	1.25	2.01	2.38	0.63
Western Link Section 1, between Racecourse Road and Dynam Road	1.25	2.01	2.38	0.63
Western Link Section 2, between Footscray Road and West Gate Freeway	1.57	2.51	2.98	0.78
Domain Tunnel and that part of the Southern Link leading into that Tunnel between the eastern portal of that Tunnel and Punt Road, other than that part of Southern Link Section 1:				
(a) between Punt Road and the exit to Boulton Parade; and				
(b) comprising Boulton Parade	1.57	2.51	2.98	0.78
Burnley Tunnel and that part of the Southern Link leading out of that Tunnel between the eastern portal of that Tunnel and Burnley Street	2.82	4.51	5.36	1.41
Southern Link Section 1, between Burnley Street and Punt Road and including that part of Southern Link Section 1:				
(a) between Punt Road and the exit to Boulton Parade; and				
(b) comprising Boulton Parade	1.25	2.01	2.38	0.63

Southern Link Section 5, between Punt Road and Burnley Street other than that part of the Southern Link leading out of the Burnley Tunnel between the eastern portal of that Tunnel and Burnley Street	1.25	2.01	2.38	0.63
Southern Link Section 1, between Glenferrie Road and Burnley Street	1.25	2.01	2.38	0.63
Southern Link Section 5, between Burnley Street and Glenferrie Road	1.25	2.01	2.38	0.63
Exhibition Street Extension	0.78	1.25	1.49	0.39
Southern Link Section 1, between Punt Road and Swan Street Intersection, other than: (a) that part of Southern Link Section 1: (i) between Punt Road and the exit to Boulton Parade; and (ii) comprising Boulton Parade; and (b) that part of the Southern Link leading into the Domain Tunnel between the eastern portal of that Tunnel and Punt Road	0.78	1.25	1.49	0.39
Southern Link Section 5, between Swan Street Intersection and Punt Road	0.78	1.25	1.49	0.39

Notes:

1. When travelling on Southern Link Section 1 between Burnley Street and Punt Road and then onto Batman Avenue, the Tollable Sections may be combined for the purposes of levying Tolls.
2. When travelling on Southern Link Section 1 and into the Domain Tunnel, the Tollable Sections may be combined for the purposes of levying Tolls.
3. A reference in the description of a Tollable Section to a part of the Southern Link between a particular street or road and Burnley Street, includes that part of the Southern Link between that particular street or road and where Burnley Street would cross the Southern Link if Burnley Street continued in a straight southerly direction from its southernmost extremity.
4. In this table:
“Boulton Parade” includes the off-ramp connecting the rest of the Southern Link to Boulton Parade;
“Burnley Tunnel” means the eastbound tunnel between Sturt Street and Burnley Street;
“Domain Tunnel” means the westbound tunnel between Punt Road and Sturt Street; and
“Swan Street Intersection” means the intersection between Swan Street and Batman Avenue.

Maximum Charge Tolls (\$/vehicle)

Category of Vehicle Tollable Section	Car	Light Commercial Vehicle	Heavy Commercial Vehicle	Motor Cycle
Trips where the passage of the Vehicle on the last Tollable Section comprising the Trip before exiting the Total Link occurs between 6.00 am and 8.00 pm	4.70	6.27	6.27	2.35
Trips where the passage of the Vehicle on the last Tollable Section comprising the Trip before exiting the Total Link occurs between 8.00 pm and 6.00 am	4.70	4.70	4.70	2.35

Day Tolls (\$/vehicle)

Category of Vehicle Tollable Section	Car	Light Commercial Vehicle	Heavy Commercial Vehicle	Motor Cycle
Day Toll	9.00	14.40	17.10	4.50

Taxi Tolls (\$/Taxi)

Trip	Taxi Toll
Trips involving use of any or all of the Tollable Sections which comprise the Western Link* and no other Tollable Sections	2.20
Trips involving use of any or all of the Tollable Sections which comprise the Southern Link** and/or Exhibition Street Extension*** and no other Tollable Sections	2.20
Trips involving use of Tollable Sections which comprise both the Western Link* and either or both of the Southern Link** and the Exhibition Street Extension***	3.85

- * The Western Link comprises the following three Tollable Sections:
1. Tullamarine Freeway Upgrade, between Moreland Road and Brunswick Road.
 2. Western Link Section 1, between Racecourse Road and Dynon Road.
 3. Western Link Section 2, between Footscray Road and West Gate Freeway.

- ** The Southern Link comprises the following eight Tollable Sections:
1. Domain Tunnel and that part of the Southern Link leading into that Tunnel between the eastern portal of that Tunnel and Punt Road, other than that part of Southern Link Section 1:

2570 G 38 19 September 2002

Victoria Government Gazette

- (a) between Punt Road and the exit to Boulton Parade; and
 - (b) comprising Boulton Parade.
2. Southern Link Section 1, between Burnley Street and Punt Road and including that part of Southern Link Section 1:
- (a) between Punt Road and the exit to Boulton Parade; and
 - (b) comprising Boulton Parade.
3. Southern Link Section 5, between Punt Road and Burnley Street other than that part of the Southern Link leading out of the Burnley Tunnel between the eastern portal of that Tunnel and Burnley Street.
4. Burnley Tunnel and that part of the Southern Link leading out of that Tunnel between the eastern portal of that Tunnel and Burnley Street.
5. Southern Link Section 1, between Glenferrie Road and Burnley Street.
6. Southern Link Section 5, between Burnley Street and Glenferrie Road.
7. Southern Link Section 1, between Punt Road and Swan Street Intersection, other than:
- (a) that part of Southern Link Section 1:
 - (i) between Punt Road and the exit to Boulton Parade; and
 - (ii) comprising Boulton Parade; and
 - (b) that part of the Southern Link leading into the Domain Tunnel between the eastern portal of that Tunnel and Punt Road.
8. Southern Link Section 5, between Swan Street Intersection and Punt Road.
- *** The Exhibition Street Extension comprises the following Tollable Section:
1. Exhibition Street Extension.

Taxi Day Tolls (\$/Taxi)

Taxi	Taxi Day toll
Metropolitan Taxi	7.70
A Taxi not being a Metropolitan Taxi	5.50

CityLink Melbourne intends that each Charge Toll, Maximum Charge Toll, Day Toll, Taxi Toll and Taxi Day Toll specified above will first apply in the quarter ending 31 December 2002.

Capitalised terms in this notice that are defined in:

- (a) the Concession Deed have, subject to paragraph (b), that meaning in this notice;
- (b) the ESEP Deed have that meaning in this notice, but only to the extent that the provision applies to the ESEP Deed, subject to the provisions of the IFA.

P G B O'SHEA
Company Secretary
CityLink Melbourne Limited
(ABN 65 070 810 678)

G R PHILLIPS
Finance Director
CityLink Melbourne Limited
(ABN 65 070 810 678)

AGREEMENT FOR THE MELBOURNE CITY LINK

Notice under Schedule 3 of the Agreement for the Melbourne City Link between the Crown in right of the State of Victoria, CityLink Melbourne Limited, Perpetual Trustee Company Limited and City Link Management Limited (the "Concession Deed").

CityLink Melbourne Limited (ABN 65 070 810 678) ("CityLink Melbourne") gives notice of the following Charge Tolls, Maximum Charge Tolls, Day Tolls, Taxi Tolls and Taxi Day Tolls for the Melbourne City Link:

Charge Tolls (\$/vehicle)

Category of Vehicle Tollable Section	Car	Light Commercial Vehicle	Heavy Commercial Vehicle	Motor Cycle
Tullamarine Freeway Upgrade, between Moreland Road and Brunswick Road	1.25	2.01	2.38	0.63
Western Link Section 1, between Racecourse Road and Dynon Road	1.25	2.01	2.38	0.63
Western Link Section 2, between Footscray Road and West Gate Freeway	1.57	2.51	2.98	0.78
Domain Tunnel and that part of the Southern Link leading into that Tunnel between the eastern portal of that Tunnel and Punt Road, other than that part of Southern Link Section 1:				
(a) between Punt Road and the exit to Boulton Parade; and				
(b) comprising Boulton Parade	1.57	2.51	2.98	0.78
Burnley Tunnel and that part of the Southern Link leading out of that Tunnel between the eastern portal of that Tunnel and Burnley Street	2.82	4.51	5.36	1.41
Southern Link Section 1, between Burnley Street and Punt Road and including that part of Southern Link Section 1:				
(a) between Punt Road and the exit to Boulton Parade; and				
(b) comprising Boulton Parade	1.25	2.01	2.38	0.63
Southern Link Section 5, between Punt Road and Burnley Street other than that part of the Southern Link leading out of the Burnley Tunnel between the eastern portal of that Tunnel and Burnley Street	1.25	2.01	2.38	0.63
Southern Link Section 1, between Glenferrie Road and Burnley Street	1.25	2.01	2.38	0.63
Southern Link Section 5, between Burnley Street and Glenferrie Road	1.25	2.01	2.38	0.63

Southern Link Section 1, between Punt Road and Swan Street Intersection, other than:				
(a) that part of Southern Link Section 1:				
(i) between Punt Road and the exit to Boulton Parade; and				
(ii) comprising Boulton Parade; and				
(b) that part of the Southern Link leading into the Domain Tunnel between the eastern portal of that Tunnel and Punt Road	0.78	1.25	1.49	0.39
Southern Link Section 5, between Swan Street Intersection and Punt Road	0.78	1.25	1.49	0.39

Notes:

- When travelling on Southern Link Section 1 between Burnley Street and Punt Road and then onto Batman Avenue, the Tollable Sections may be combined for the purposes of levying Tolls.
- When travelling on Southern Link Section 1 and into the Domain Tunnel, the Tollable Sections may be combined for the purposes of levying Tolls.
- A reference in the description of a Tollable Section to a part of the Southern Link between a particular street or road and Burnley Street, includes that part of the Southern Link between that particular street or road and where Burnley Street would cross the Southern Link if Burnley Street continued in a straight southerly direction from its southernmost extremity.
- In this table:
 - “Boulton Parade” includes the off-ramp connecting the rest of the Southern Link to Boulton Parade;
 - “Burnley Tunnel” means the eastbound tunnel between Sturt Street and Burnley Street;
 - “Domain Tunnel” means the westbound tunnel between Punt Road and Sturt Street; and
 - “Swan Street Intersection” means the intersection between Swan Street and Batman Avenue.

Maximum Charge Tolls (\$/vehicle)

Category of Vehicle	Car	Light Commercial Vehicle	Heavy Commercial Vehicle	Motor Cycle
Trips where the passage of the Vehicle on the last Tollable Section comprising the Trip before exiting the Link occurs between 6.00 am and 8.00 pm	4.70	6.27	6.27	2.35
Trips where the passage of the Vehicle on the last Tollable Section comprising the Trip before exiting the Link occurs between 8.00 pm and 6.00 am	4.70	4.70	4.70	2.35

Day Tolls (\$/vehicle)

Category of Vehicle	Car	Light Commercial Vehicle	Heavy Commercial Vehicle	Motor Cycle
Day Toll	9.00	14.40	17.10	4.50

Taxi Tolls (\$/Taxi)

Trip	Taxi Toll
Trips involving use of any or all of the Tollable Sections which comprise the Western Link* and no other Tollable Sections	2.20
Trips involving use of any or all of the Tollable Sections which comprise the Southern Link** and no other Tollable Sections	2.20
Trips involving use of Tollable Sections which comprise both the Western Link* and the Southern Link**	3.85

* The Western Link comprises the following three Tollable Sections:

1. Tullamarine Freeway Upgrade, between Moreland Road and Brunswick Road.
2. Western Link Section 1, between Racecourse Road and Dynon Road.
3. Western Link Section 2, between Footscray Road and West Gate Freeway.

** The Southern Link comprises the following eight Tollable Sections:

1. Domain Tunnel and that part of the Southern Link leading into that Tunnel between the eastern portal of that Tunnel and Punt Road, other than that part of Southern Link Section 1:
 - (a) between Punt Road and the exit to Boulton Parade; and
 - (b) comprising Boulton Parade.
2. Southern Link Section 1, between Burnley Street and Punt Road and including that part of Southern Link Section 1:
 - (a) between Punt Road and the exit to Boulton Parade; and
 - (b) comprising Boulton Parade.
3. Southern Link Section 5, between Punt Road and Burnley Street other than that part of the Southern Link leading out of the Burnley Tunnel between the eastern portal of that Tunnel and Burnley Street.
4. Burnley Tunnel and that part of the Southern Link leading out of that Tunnel between the eastern portal of that Tunnel and Burnley Street.
5. Southern Link Section 1, between Glenferrie Road and Burnley Street.
6. Southern Link Section 5, between Burnley Street and Glenferrie Road.
7. Southern Link Section 1, between Punt Road and Swan Street Intersection, other than:
 - (a) that part of Southern Link Section 1:

2574 G 38 19 September 2002

Victoria Government Gazette

- (i) between Punt Road and the exit to Boulton Parade; and
 - (ii) comprising Boulton Parade; and
 - (b) that part of the Southern Link leading into the Domain Tunnel between the eastern portal of that Tunnel and Punt Road.
8. Southern Link Section 5, between Swan Street Intersection and Punt Road.

Taxi Day Tolls (\$/Taxi)

Taxi	Taxi Day toll
Metropolitan Taxi	7.70
A Taxi not being a Metropolitan Taxi	5.50

CityLink Melbourne intends that each Charge Toll, Maximum Charge Toll, Day Toll, Taxi Toll and Taxi Day Toll specified above will first apply in the quarter ending 31 December 2002.

Capitalised terms in this notice that are defined in the Concession Deed have the same meaning as given by the Concession Deed.

P G B O'SHEA
 Company Secretary
 CityLink Melbourne Limited
 (ABN 65 070 810 678)

G R PHILLIPS
 Finance Director
 CityLink Melbourne Limited
 (ABN 65 070 810 678)

Victoria Government Gazette

G 38 19 September 2002 2575

AGREEMENT FOR THE EXHIBITION STREET EXTENSION PROJECT

Notice under Schedule 1 of the Agreement for the Exhibition Street Extension Project between the Crown in right of the State of Victoria and City Link Extension Pty Limited (the "ESEP Deed").

City Link Extension Pty Limited (ABN 40 082 058 615) ("Clepc") gives notice of the following Charge Tolls for the Exhibition Street Extension:

Charge Tolls (\$/vehicle)

Category of Vehicle	Car	Light Commercial Vehicle	Heavy Commercial Vehicle	Motor Cycle
Tollable Section				
Exhibition Street Extension	0.78	1.25	1.49	0.39

Clepc intends that these Charge Tolls will first apply in the quarter ending 31 December 2002.

Capitalised terms in this notice that are defined in the ESEP Deed have the same meaning as given by the ESEP Deed.

P G B O'SHEA
Company Secretary
City Link Extension Pty Limited
ABN 40 082 058 615

G R PHILLIPS
Finance Director
City Link Extension Pty Limited
ABN 40 082 058 615

2576 G 38 19 September 2002

Victoria Government Gazette

Planning and Environment Act 1987

DAREBIN PLANNING SCHEME

Notice of Approval of Amendment

Amendment C19

The Minister for Planning has approved Amendment C19 to the Darebin Planning Scheme.

The Amendment comes into operation on the date this notice is published in the Government Gazette.

The Amendment facilitates development of 6.65 hectare residential subdivision and a 9 hectare Central Creek Grasslands Conservation Reserve.

The Minister has granted the following permits under Division 5 Part 4 of the Act:

Permit No.: D859/2000.

Description of land: 183–207 Mahoneys Road, Reservoir.

A copy of the Amendment and permit can be inspected, free of charge, during office hours, at the Department of Infrastructure, Planning Information Centre, Upper Plaza, Nauru House, 80 Collins Street, Melbourne and at the offices of the Darebin City Council, 350 High Street, Preston.

PAUL JEROME
Executive Director
Planning, Heritage and
Building Division
Department of Infrastructure

Planning and Environment Act 1987

WELLINGTON PLANNING SCHEME

Notice of Approval of Amendment

Amendment C15

The Minister for Planning has approved Amendment C15 to the Wellington Planning Scheme.

The Amendment comes into operation on the date this notice is published in the Government Gazette.

The Amendment:

- introduces changes to clause 21.09 of the Municipal Strategic Statement to recognise the strategic importance of the Basslink Electricity Interconnector Project;

- incorporates the Basslink – Land Use and Development Controls, 2002, into the Planning Scheme in the schedules to clauses 52.03 and 81, that allow the Basslink Electricity Interconnector Project to proceed without a planning permit subject to the Basslink – Land Use and Development Controls, 2002;
- includes the Minister for Planning in the schedule to clause 61, as the responsible authority for administering and enforcing the Wellington Planning Scheme in respect of the provisions of the Basslink – Land Use and Development Controls, 2002.

A copy of the Amendment can be inspected, free of charge, during office hours, at the Department of Infrastructure, Planning Information Centre, Upper Plaza, Nauru House, 80 Collins Street, Melbourne, the Department of Infrastructure Eastern Region Office, 120 Kay Street, Traralgon and the Wellington Shire Council Offices, 70 Foster Street, Sale.

PAUL JEROME
Executive Director
Planning, Heritage and
Building Division
Department of Infrastructure

Planning and Environment Act 1987

LA TROBE PLANNING SCHEME

Notice of Approval of Amendment

Amendment C20

The Minister for Planning has approved Amendment C20 to the La Trobe Planning Scheme.

The Amendment comes into operation on the date this notice is published in the Government Gazette.

The Amendment:

- introduces changes to clauses 21.01 and 21.04 of the Municipal Strategic Statement to recognise the strategic importance of the Basslink Electricity Interconnector Project;
- incorporates the Basslink – Land Use and Development Controls, 2002, in the Planning Scheme in the schedules to clauses 52.03 and 81, that allow the Basslink Electricity Interconnector Project to proceed without a planning permit subject to the

Basslink – Land Use and Development Controls, 2002;

- includes the Minister for Planning in the schedule to clause 61, as the responsible authority for administering and enforcing the La Trobe Planning Scheme in respect of the provisions of the Basslink – Land Use and Development Controls, 2002.

A copy of the Amendment can be inspected, free of charge, during office hours, at the Department of Infrastructure, Planning Information Centre, Upper Plaza, Nauru House, 80 Collins Street, Melbourne, the Department of Infrastructure Eastern Region Office, 120 Kay Street, Traralgon and the City of Latrobe Offices, 34–38 Kay Street, Traralgon.

PAUL JEROME
Executive Director
Planning, Heritage and
Building Division
Department of Infrastructure

Planning and Environment Act 1987

MONASH PLANNING SCHEME

Notice of Approval of Amendment Amendment C7

The Minister for Planning has approved Amendment C7 to the Monash Planning Scheme.

The Amendment comes into operation on the date this notice is published in the Government Gazette.

The Amendment rezones land along the northern side of High Street Road, Glen Waverley immediately west of Dandenong Creek including 1021 High Street Road, Glen Waverley from Public Park and Recreation Zone to Road Zone – Category 1.

A copy of the Amendment can be inspected, free of charge, during office hours, at the Department of Infrastructure, Planning Information Centre, Upper Plaza, Nauru House, 80 Collins Street, Melbourne and at the offices of the Monash City Council, 293 Springvale Road, Glen Waverley.

PAUL JEROME
Executive Director
Planning, Heritage and
Building Division
Department of Infrastructure

Planning and Environment Act 1987

WHITEHORSE PLANNING SCHEME

Notice of Approval of Amendment Amendment C27

The Minister for Planning has approved Amendment C27 to the Whitehorse Planning Scheme.

The Amendment comes into operation on the date this notice is published in the Government Gazette.

The Amendment includes the land at 355 Station Street, Box Hill South in a Development Plan Overlay (DPO) and introduces a Development Plan Overlay Schedule (Schedule 3).

A copy of the Amendment can be inspected, free of charge, during office hours, at the Department of Infrastructure, Planning Information Centre, Upper Plaza, Nauru House, 80 Collins Street, Melbourne and at the offices of the Whitehorse City Council, Customer Service Centre, 379–397 Whitehorse Road, Nunawading.

PAUL JEROME
Executive Director
Planning, Heritage and
Building Division
Department of Infrastructure

Planning and Environment Act 1987

WHITEHORSE PLANNING SCHEME

Notice of Approval of Amendment Amendment C42

The Minister for Planning has approved Amendment C42 to the Whitehorse Planning Scheme.

The Amendment comes into operation on the date this notice is published in the Government Gazette.

The Amendment corrects errors in the Whitehorse Planning Scheme inadvertently made as a result of the gazettal of Amendment C33 to the Whitehorse Planning Scheme on 27 June 2002. In particular, the Amendment makes changes to the Schedules to Clauses 43.01, 52.03 and 81 of the Scheme.

A copy of the Amendment can be inspected, free of charge, during office hours, at the

2578 G 38 19 September 2002

Victoria Government Gazette

Department of Infrastructure, Planning Information Centre, Upper Plaza, Nauru House, 80 Collins Street, Melbourne and at the offices of the Whitehorse City Council, 379–397 Whitehorse Road, Nunawading.

PAUL JEROME
Executive Director
Planning, Heritage and
Building Division
Department of Infrastructure

Planning and Environment Act 1987

YARRA PLANNING SCHEME

Notice of Approval of Amendment
Amendment C41

The Minister for Planning has approved Amendment C41 to the Yarra Planning Scheme.

The Amendment comes into operation on the date this notice is published in the Government Gazette.

The Amendment includes the following changes:

- a) To make mapping changes to include:
- Church Street Bridge, Church Street, Richmond.
 - Former Melbourne Veterinary College, 38-40 Brunswick Street, Fitzroy.
 - Cathedral Hall, 20 Brunswick Street, Fitzroy.
 - Vaocluse College, Darlington Parade, Richmond

in the planning scheme maps in accordance with mapping under the Victorian Heritage Register for these sites.

- b) To include these sites in the schedule to the Heritage Overlay.
- c) To renumber the Heritage Overlay entry for the Former Fairfield Hospital Grounds, Yarra Bend Road, Fairfield to correct a duplicate numbering anomaly.

A copy of the Amendment can be inspected, free of charge, during office hours, at the Department of Infrastructure, Planning Information Centre, Upper Plaza, Nauru House, 80 Collins Street, Melbourne and at the offices of the Yarra City Council, Richmond Town Hall, 333 Bridge Road, Richmond.

PAUL JEROME
Executive Director
Planning, Heritage and
Building Division
Department of Infrastructure

Planning and Environment Act 1987

YARRA RANGES PLANNING SCHEME

Notice of Approval of Amendment
Amendment C26

The Minister for Planning has approved Amendment C26 to the Yarra Ranges Planning Scheme.

The Amendment comes into operation on the date this notice is published in the Government Gazette.

The Amendment introduces a site specific provision into Clause 52.03 of the Yarra Ranges Planning Scheme to allow for the subdivision of land at 54 Auburn Road, Healesville into 2 lots. The land already contains two units which were allowed by a planning permit issued under the former Yarra Ranges Planning Scheme.

A copy of the Amendment can be inspected, free of charge, during office hours, at the Department of Infrastructure, Planning Information Centre, Upper Plaza, Nauru House, 80 Collins Street, Melbourne and at the offices of the Yarra Ranges Council, Anderson Street, Lilydale.

PAUL JEROME
Executive Director
Planning, Heritage and
Building Division
Department of Infrastructure

ORDERS IN COUNCIL

Crown Land (Reserves) Act 1978

NOTICE OF INTENTION TO REVOKE
TEMPORARY RESERVATION

The Governor in Council under section 10 of the **Crown Land (Reserves) Act 1978** gives notice of intention to revoke the following temporary reservation:

MELBOURNE — The temporary reservation by Order in Council of 20 April, 1982 of an area of 5769 square metres of land being Crown Allotment 22, Section 30, City of Melbourne, Parish of Melbourne North as a site for Public Offices, revoked as to part by Order in Council of 7 April, 1992 so far as the balance remaining containing 4295 square metres. — (Rs 10150).

This Order is effective from the date on which it is published in the Government Gazette.

Dated 17 September 2002

Responsible Minister
SHERRYL GARBUTT
Minister for Environment
and Conservation

HELEN DOYE
Clerk of the Executive Council

Crown Land (Reserves) Act 1978

NOTICE OF INTENTION TO REVOKE
TEMPORARY RESERVATION

The Governor in Council under section 10 of the **Crown Land (Reserves) Act 1978** gives notice of intention to revoke the following temporary reservation:

YEA — The temporary reservation by Order in Council of 25 May, 1999 of an area of 13 hectares, more or less, of land in the Township and Parish of Yea as a site for Public Purposes (Rail Trail), so far only as the portion containing 4810 square metres, more or less, being Crown Allotment 3E, Section 12, Township of Yea as shown on Plan No. LEGL./99-64 lodged in the Central Plan Office. — (Rs 17055).

This Order is effective from the date on which it is published in the Government Gazette.

Dated 17 September 2002

Responsible Minister
SHERRYL GARBUTT
Minister for Environment
and Conservation

HELEN DOYE
Clerk of the Executive Council

Crown Land (Reserves) Act 1978

REVOCATION OF TEMPORARY
RESERVATIONS

The Governor in Council under section 10 of the **Crown Land (Reserves) Act 1978** revokes the following temporary reservations:

BARWIDGEE — The temporary reservation by Order in Council of 12 November, 1957 of an area of 4.55 hectares of land in the Parish of Barwidgee as a site for Supply of Gravel. — (Rs 7678).

YARIMA — The temporary reservation by Order in Council of 17 March, 1953 of an area of 1.42 hectares of land in Section C, Parish of Yarima as a site for Public Hall and a Public Park. — (Rs 7075).

YARIMA — The temporary reservation by Order in Council of 27 May, 1980 of an area of 1.214 hectares of land being Crown Allotment 1A, Section C, Parish of Yarima as a site for Public Park. — (Rs 11045).

This Order is effective from the date on which it is published in the Government Gazette.

Dated 17 September 2002

Responsible Minister
SHERRYL GARBUTT
Minister for Environment
and Conservation

HELEN DOYE
Clerk of the Executive Council

2580 G 38 19 September 2002

Victoria Government Gazette

Crown Land (Reserves) Act 1978
REVOCATION OF TEMPORARY
RESERVATIONS

The Governor in Council under section 10 of the **Crown Land (Reserves) Act 1978** revokes the following temporary reservations:

CARLTON — The temporary reservation by Order in Council of 11 December, 2001 of an area of 5962 square metres of land being Crown Allotments 13C, 13F and 13G, Section 39, At Carlton, Parish of Jika Jika as a site for Hospital purposes, so far only as the portion containing 78 square metres shown as Crown Allotment 2006, At Carlton, Parish of Jika Jika on Original Plan No. 121798 lodged in the Central Plan Office. — (Rs 6247).

CRANBOURNE — The temporary reservation by Order in Council of 7 July, 1987 of an area of 98.17 hectares of land being Crown Allotment 17A, Parish of Cranbourne as a site for a Racecourse, revoked as to part by Order in Council of 28 November, 2000 so far only as the portion containing 1.731 hectares being Crown Allotment 2002, Parish of Cranbourne as indicated by hatching on plan published in the Government Gazette on 8 August, 2002 page – 2200. — (Rs 13133).

LORNE — The temporary reservation by Order in Council of 3 April, 1984 of an area of 140 square metres of land being Crown Allotment 3A, No Section, Township of Lorne, Parish of Lorne as a site for an Ambulance Station. — (Rs 12594).

WAILL — The temporary reservation by Order in Council of 26 March, 1901 of an area of 2.023 hectares of land in the Parish of Waill (formerly part of subdivision 34 of Mallee allotment 669) as a site for a Night-soil Depot. — (Rs 3152).

This Order is effective from the date on which it is published in the Government Gazette.

Dated 17 September 2002

Responsible Minister
SHERRYL GARBUTT
 Minister for Environment
 and Conservation

HELEN DOYE
 Clerk of the Executive Council

Crown Land (Reserves) Act 1978
TEMPORARY RESERVATION OF
CROWN LANDS

The Governor in Council under section 4(1) of the **Crown Land (Reserves) Act 1978** temporarily reserves the following Crown lands which in his opinion are required for the purposes mentioned :-

MUNICIPAL DISTRICT OF THE
EAST GIPPSLAND SHIRE COUNCIL

BEMM — Public Hall, 4023 square metres, being Crown Allotment 1A, Section D, Township of Bemm, Parish of Bemm as indicated by hatching on plan hereunder. (GP1014) — (2012332).

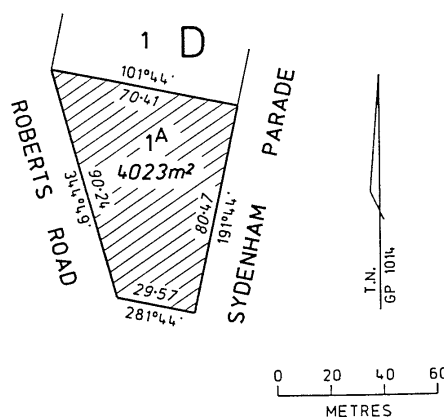

MUNICIPAL DISTRICT OF THE
NILLUMBIK SHIRE COUNCIL

QUEENSTOWN — Public purposes, 1727 square metres, being Crown Allotment 2001, Township of Queenstown, Parish of Queenstown as indicated by hatching on plan hereunder. (GP1057) — (Rs 1023).

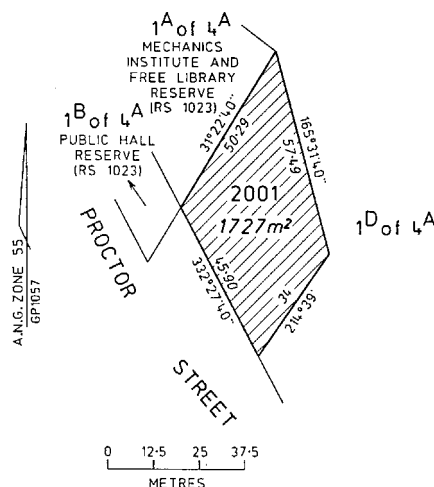

MUNICIPAL DISTRICT OF THE
MORNINGTON PENINSULA
SHIRE COUNCIL

TYABB — Conservation of an area of natural interest, combined area 38.42 hectares being Crown Allotments 57H, 57J, 2001 and 2002, Parish of Tyabb as indicated by hatching on plans hereunder. (GP981 & 981-B) — (CL/07-0014).

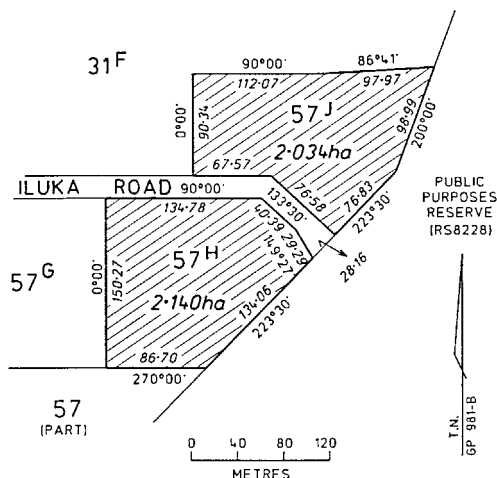

Total Area of hatched portions is 4.174ha

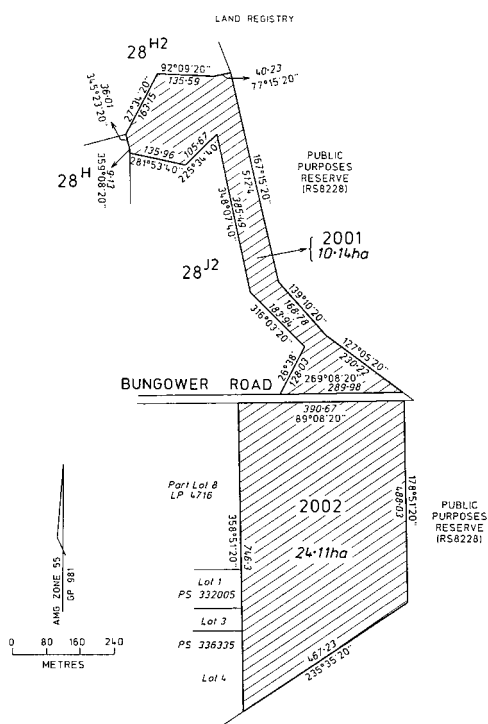

Total Area of hatched portions is 34.25ha

This Order is effective from the date on which it is published in the Government Gazette.

Dated 17 September 2002

Responsible Minister
SHERRYL GARBUTT
Minister for Environment
and Conservation

HELEN DOYE
Clerk of the Executive Council

Land Act 1958

CLOSURE OF UNUSED ROAD

The Governor in Council under section 349 of the Land Act 1958 and with the concurrence in writing of the municipality in which the road is situated closes the following unused road:

MUNICIPAL DISTRICT OF THE
MORNINGTON PENINSULA
SHIRE COUNCIL

TYABB — The road in the Parish of Tyabb being Crown Allotment 2003 as indicated by hatching on plan hereunder. (GP981-A) — (CL/07-0014).

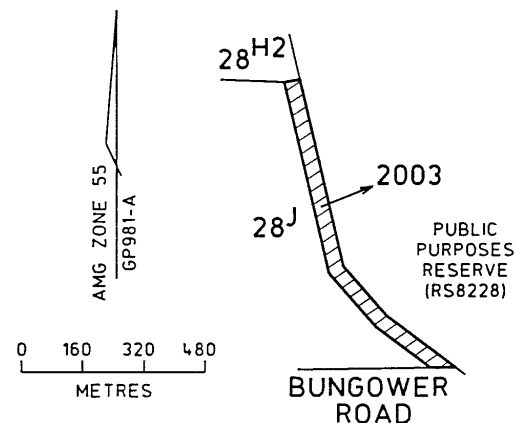

This Order is effective from the date on which it is published in the Government Gazette.

Dated 17 September 2002

Responsible Minister
SHERRYL GARBUTT
Minister for Environment
and Conservation

HELEN DOYE
Clerk of the Executive Council

2582 G 38 19 September 2002

Victoria Government Gazette

Land Act 1958**CLOSURE OF UNUSED ROAD**

The Governor in Council under section 349 of the **Land Act 1958** and with the concurrence in writing of the municipality in which the road is situated and the owners of land adjoining the road closes the following unused road:

**MUNICIPAL DISTRICT OF THE
MOORABOOL SHIRE COUNCIL**

BALLAN — The road in the Township of Ballan, Parish of Ballan being Crown Allotment 2001 as indicated by hatching on plan hereunder. (GP962) — (07/L1-4825).

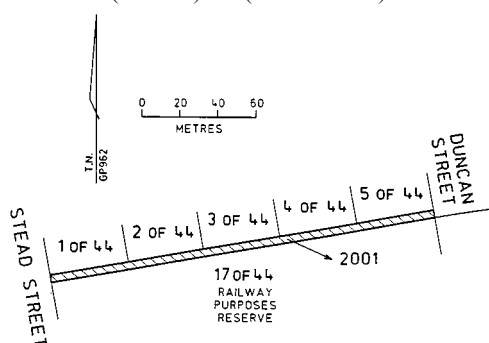

This Order is effective from the date on which it is published in the Government Gazette.

Dated 17 September 2002

Responsible Minister
SHERRYL GARBUTT
Minister for Environment
and Conservation

HELEN DOYE
Clerk of the Executive Council

Financial Management Act 1994

**DECLARATION OF THE GOVERNOR IN
COUNCIL OF A BODY CORPORATE TO BE
A BODY TO WHICH SECTION 53A
APPLIES**

Order in Council

The Governor in Council declares –

- (a) under section 53A(2) of the **Financial Management Act 1994** (the “Act”), Phytogene Pty Ltd (ACN 098 823 235) to be a body to which section 53A of the Act applies; and

- (b) under section 53A(3) of the Act, the Minister for Agriculture to be the relevant Minister in relation to Phytogene Pty Ltd (ACN 098 823 235) for the purposes of section 53A of the Act.

Dated 17 September 2002

Responsible Minister
JOHN LENDERS MP
Minister for Finance

HELEN DOYE
Clerk of the Executive Council

Gas Safety Act 1997

**AMENDMENT OF GAS COMPANY
DECLARATION**

Order in Council

The Governor in Council acting under section 5 of the **Gas Safety Act 1997** (“the Act”) declares the Mount Buller Alpine Resort Management Board, previously declared to be a gas company by Order in Council published in the Government Gazette on 21 January 1999 (as amended by Order in Council published in the Government Gazette on 4 May 2000), to no longer be a gas company for the purposes of the Act.

This Order comes into effect on the day on which it is published in the Government Gazette.

Dated 17 September 2002

Responsible Minister
CANDY BROAD
Minister for Energy
and Resources

HELEN DOYE
Clerk of the Executive Council

Gas Safety Act 1997

DECLARATION OF GAS COMPANY

Order in Council

The Governor in Council acting under section 5 of the **Gas Safety Act 1997** (“the Act”) declares Indigo Way Services (ABN 34 627 466 758) to be a gas company for the purposes of the Act.

This Order comes into effect on the day on which it is published in the Government Gazette.

Dated 17 September 2002

Responsible Minister
CANDY BROAD
Minister for Energy
and Resources

HELEN DOYE
Clerk of the Executive Council

Melbourne City Link Act 1995

ORDER DECREASING THE PROJECT AREA

The Governor in Council, under section 8(1) of the **Melbourne City Link Act 1995** varies the Melbourne City Link Project area by decreasing the Project area by the land shown as Crown Allotment 20C of Section 59, Parish of Melbourne South, City of Port Melbourne, on the plan numbered OP119349-B lodged in the Central Plan Office.

This Order takes effect on and from the date it is published in the Government Gazette.

Dated 17 September 2002

Responsible Minister:
PETER BATCHELOR
Minister for Transport

HELEN DOYE
Clerk of the Executive Council



Marine Act 1988

APPROVAL OF APPROVED ANALYSTS

Order in Council

The Governor in Council acting under section 27 of the **Interpretation of Legislation Act 1984** and section 32 of the **Marine Act 1988** revokes the Order made on 19 December 2000 and published in the Government Gazette on 11 January 2001 and by this Order approves the following persons as properly qualified analysts for the purposes of that section:

ARMITT, Wendy Anne
BURKE, Jodie
CANAVAN, Gavan John
GERSTNER-STEVENS, Joanne Frances
JONES, Linda Maree

KING, Christopher
KOTSOS, Alex
PEACE, Allison Wendy
QUINN, Catherine Anne
STEPHEN, Deborah Jane
TAUPIN, Jane Moira
WOODMAN, Peter Andrew

This Order is effective on and from the day on which it is published in the Government Gazette.

Dated 17 September 2002

Responsible Minister:
CANDY BROAD
Minister for Ports

HELEN DOYE
Clerk of the Executive Council

Road Safety Act 1986

APPROVAL OF APPROVED ANALYSTS

Order in Council

The Governor in Council acting under section 27 of the **Interpretation of Legislation Act 1984** and section 57 of the **Road Safety Act 1986** revokes the order made on 12 December 2000 and published in the Government Gazette on 14 December 2000 and by this Order approves the following persons as properly qualified analysts for the purposes of that section:

ARMITT, Wendy Anne
BURKE, Jodie
CANAVAN, Gavan John
GERSTNER-STEVENS, Joanne Frances
GEROSTAMOULOS, Jim
JONES, Linda Maree
KING, Christopher
KOTSOS, Alex
PEACE, Alison Wendy
QUINN, Catherine Anne
STEPHEN, Deborah Jane
TAUPIN, Jane Moira
WOODMAN, Peter Andrew

This Order is effective on and from the day on which it is published in the Government Gazette.

Dated 17 September 2002

Responsible Minister:
PETER BATCHELOR
Minister for Transport

HELEN DOYE
Clerk of the Executive Council

APPOINTMENTS

Pharmacists Act 1974

PHARMACY BOARD OF VICTORIA

Appointment

Order in Council

The Governor-in-Council, under section 4(3) of the **Pharmacists Act 1974**, and on the recommendation of the Minister for Health, appoints:

Russell John Grosvenor

as a member of the Pharmacy Board of Victoria under category prescribed by section 4(1)(c).

The terms and conditions of the appointment are contained in the attached schedule.

Dated 17 September 2002

Responsible Minister:

JOHN THWAITES

Minister for Health

HELEN DOYE

Clerk of the Executive Council

Pharmacists Act 1974

PHARMACY BOARD OF VICTORIA

Appointment

Schedule to the Order in Council

1. Appointment Arrangements

The appointment is part-time.

2. Period of Appointment

From the Date of the Order to 22 February 2005.

3. Termination Arrangements

Under Section 4(3) the Governor in Council may at any time by notice published in the Government Gazette –

- (a) declare that the person who is president shall cease to be president;
- (b) remove any member (including the president) from the Board;

Under Section 4(7) when a member of the Board is absent without leave for a period of three months from all meetings of the Board and has also been absent from three consecutive meetings of the Board the office of such a member shall become vacant.

4. Payment Provisions

Under section 4(11) of the **Pharmacists Act**

1974 members of the Board shall be entitled to receive such fees and allowances as are fixed from time to time by the Governor in Council and currently set at:

- \$240 per day for the Chairperson.
- \$187.50 per day for Members.

5. Superannuation Obligations

Superannuation contributions will be paid by the employer in accordance with the Commonwealth's **Superannuation Guarantee Act 1992**.

6. Travel and Personal Expenses Arrangements

Section 4(11), "the members of the Board shall be entitled to receive such fees and allowances as are fixed from time to time by the Governor in Council", covers travel and personal expenses.

7. Leave Arrangements

There are no paid leave provisions for these part-time statutory positions.

8. Prior Service

N/a.

This page left blank intentionally

**SUBORDINATE LEGISLATION ACT 1994
NOTICE OF MAKING OF STATUTORY
RULES**

Notice is hereby given under Section 17 (2) of the **Subordinate Legislation Act 1994** of the making of the following Statutory Rules:

80. *Statutory Rule:* Health (Medical Radiation Technologists) (Fees) Regulations 2002
Authorising Act: Health Act 1958
Date of making: 17 September 2002
81. *Statutory Rule:* Health (Radiation Safety) (Fees) Regulations 2002
Authorising Act: Health Act 1958
Date of making: 17 September 2002

**SUBORDINATE LEGISLATION ACT 1994
NOTICE THAT STATUTORY RULES ARE
OBTAINABLE**

Notice is hereby given under Section 17 (3) of the **Subordinate Legislation Act 1994** that the following Statutory Rules were first obtainable from Information Victoria, 356 Collins Street, Melbourne on the date specified:

77. *Statutory Rule:* Adoption (Amendment) Regulations 2002
Authorising Act: Adoption Act 1984
Date first obtainable: 17 September 2002
Code A
78. *Statutory Rule:* Fisheries (Amendment) Regulations 2002
Authorising Act: Fisheries Act 1995
Date first obtainable: 17 September 2002
Code A
79. *Statutory Rule:* Health Services (Private Hospitals and Day Procedure Centres) Regulations 2002
Authorising Act: Health Services Act 1988
Date first obtainable: 17 September 2002
Code D

As from 1 April 2002, the pricing structure for the Victoria Government Gazette and Victorian Government Legislation will be as follows.

Retail price will vary according to the number of pages in each special or periodical gazette. The table below sets out the prices that apply.

<i>Price Code</i>	<i>No. of Pages (Including cover and blank pages)</i>	<i>Price*</i>
A	1–16	\$3.65
B	17–32	\$5.40
C	33–48	\$7.40
D	49–96	\$11.50
E	97–144	\$14.85
F	145–192	\$17.55
G	193–240	\$20.25
H	241–288	\$21.55
I	289–352	\$24.25
J	353–416	\$28.35
K	417–480	\$32.35
L	481–544	\$37.75
M	545–608	\$43.15
N	609–672	\$48.55
O	673–736	\$53.90
P	737–800	\$59.30

**All Prices Include GST*

ADVERTISERS PLEASE NOTE

As from 19 September 2002

The last Special Gazette was No. 166 dated 18 September 2002

The last Periodical Gazette was No. 1 dated 4 June 2002

CONTENTS

	Page
Estates of Deceased Persons	2472
Government and Outer Budget Sector	
Agencies Notices	2537
Orders in Council	2579
Acts — Crown Land Reserves; Land; Financial Management; Gas Safety; Melbourne City Link; Marine; Road Safety	
Private Advertisements	2471
Proclamations	2536
Appointments	2584

The Victoria Government Gazette is published by The Craftsman Press Pty. Ltd. with the authority of the Government Printer for the State of Victoria
© State of Victoria 2002

ISSN 0819-5471

This publication is copyright. No parts may be reproduced by any process except in accordance with the provisions of the Copyright Act.

Products and services advertised in this publication are not endorsed by The Craftsman Press Pty. Ltd. or the State of Victoria and neither of them accepts any responsibility for the content or the quality of reproduction. The Craftsman Press Pty. Ltd. reserves the right to reject any advertising material it considers unsuitable for government publication.

Address all enquiries to the Government Printer for the State of Victoria
Government Information and Communications Branch
Department of Premier and Cabinet
Level 3, 356 Collins Street
Melbourne 3000
Victoria Australia

RETAIL SALES

Information Victoria Bookshop
356 Collins Street Melbourne 3000.
Telephone enquiries 1300 366 356

City Graphics
Level 1, 520 Bourke Street
Melbourne 3000
Telephone enquiries (03) 9600 0977

Recommended Retail Price \$1.85 (includes GST)

Government and Outer Budget Sector Agencies please note
STYLE REQUIREMENTS.

To ensure that material received can be reproduced, and that errors are minimised, the following guidelines are to be observed when submitting material by fax.

Fax resolution:

Material sent by fax should be transmitted using Fine Resolution (200 dots per inch by 200 dpi).

Font size:

Use 12 point (10 pitch) or larger.

Font Style:

Clear plain font styles, such as Helvetica, should be used.

Graphics:

Line drawings should be transmitted as large as possible to ensure clarity. Drawings up to A4 size sent by fax using Fine Resolution provide a good quality for reproduction.

Avoid:

Italics, underlining and full justification.

Ensure document is square when sending as documents that are sent skewed are difficult to read and process.

ISSN 0819-5471



9 770819 549410